

## Workshop Manual

León 2013 ➤

León ST 2013 ➤

4-cylinder diesel engine (1.6 l and 2.0 l 4V, TDI Common Rail, EA288)									
Engine ID	CLH A	CLH B	CKF C	CUP A	CRV A	CRV C	CRM B	CKF B	CUN A
	CRK B	CRL B	CRB C	CXX B	CXX A	DBK A	CRG A	CRL D	DDY A
	DDY B	DCY A							

Edition 02.2017

## List of Workshop Manual Repair Groups

### Repair Group

- 00 - Technical data
- 10 - Removing and installing engine
- 13 - Crankshaft group
- 15 - Cylinder head, valve gear
- 17 - Lubrication
- 19 - Cooling
- 21 - Turbocharging/supercharging
- 23 - Mixture preparation - injection
- 26 - Exhaust system
- 28 - Glow plug system

Technical information should always be available to the foremen and mechanics, because their careful and constant adherence to the instructions is essential to ensure vehicle road-worthiness and safety. In addition, the normal basic safety precautions for working on motor vehicles must, as a matter of course, be observed.

---

## Contents

<b>00 - Technical data</b> .....	<b>1</b>
<b>1 Safety instructions</b> .....	<b>1</b>
1.1 Safety precautions when working on fuel supply system .....	1
1.2 Safety precautions for working on vehicles with start-stop system .....	1
1.3 Safety precautions during road tests in which testing and measuring equipment is used ..	2
1.4 Safety precautions when working on the cooling system .....	2
<b>2 Identification</b> .....	<b>4</b>
2.1 Engine identification number / engine data .....	4
<b>3 Repair notes</b> .....	<b>13</b>
3.1 Cleaning rules .....	13
3.2 Foreign particles in engine .....	13
3.3 Contact corrosion .....	13
3.4 Routing and attaching pipes and wiring .....	14
3.5 Installing radiators and condensers .....	14
<b>10 - Removing and installing engine</b> .....	<b>15</b>
<b>1 Removing and installing the engine</b> .....	<b>15</b>
1.1 Engine removal .....	15
1.2 Separating engine and gearbox .....	34
1.3 Securing engine to engine and gearbox support .....	37
1.4 Installing engine .....	39
<b>2 Engine/gearbox mountings</b> .....	<b>44</b>
2.1 Exploded view - assembly mountings .....	44
2.2 Removing and installing engine mountings .....	45
2.3 Removing and installing gearbox mounting .....	46
2.4 Removing and installing pendulum support .....	49
2.5 Supporting engine in installation position .....	51
2.6 Adjusting assembly mounting .....	54
2.7 Checking adjustment of assembly mountings .....	55
<b>3 Engine cover</b> .....	<b>56</b>
3.1 Removing and installing engine cover panel .....	56
<b>13 - Crankshaft group</b> .....	<b>57</b>
<b>1 Cylinder block (pulley end)</b> .....	<b>57</b>
1.1 Exploded view - cylinder block (pulley end) .....	57
1.2 Assembly overview - Sealing flange, belt pulley end. ....	59
1.3 Removing and installing poly V-belt .....	59
1.4 Removing and installing tensioner for poly V-belt .....	61
1.5 Removing and installing vibration damper .....	61
1.6 Removing and installing ancillary bracket .....	61
1.7 Removing and installing engine support .....	63
1.8 Removing and installing sealing flange - pulley end .....	64
<b>2 Cylinder block, gearbox end</b> .....	<b>67</b>
2.1 Exploded view - cylinder block, gearbox end .....	67
2.2 Removing and installing flywheel .....	68
2.3 Removing and installing sealing flange (gearbox end) .....	69
<b>3 Crankshaft</b> .....	<b>77</b>
3.1 Assembly overview - crankshaft .....	77
3.2 Crankshaft dimensions .....	78
3.3 Renewing needle bearing in crankshaft .....	78
3.4 Measure axial play of crankshaft .....	80
<b>4 Pistons and conrods</b> .....	<b>82</b>

4.1	Exploded view - pistons and conrods	82
4.2	Removing and installing pistons	84
4.3	Measuring piston projection at TDC	86
4.4	Checking pistons and cylinder bores	88
4.5	Checking radial clearance of conrod bearings	89
<b>15</b>	<b>Cylinder head, valve gear</b>	<b>90</b>
<b>1</b>	<b>Cylinder head</b>	<b>90</b>
1.1	Exploded view - cylinder head	90
1.2	Assembly overview - cylinder head cover	92
1.3	Removing and installing cylinder head	94
1.4	Cylinder head cover: removing and installing	103
1.5	Removing and installing seals for injectors	106
1.6	Removing and installing camshaft housing	107
1.7	Check compression pressure	112
<b>2</b>	<b>Toothed belt drive</b>	<b>114</b>
2.1	Exploded view - toothed belt cover	114
2.2	Exploded view - toothed belt	115
2.3	Removing and installing toothed belt cover	116
2.4	Timing belt: removing, fitting, tensioning	120
2.5	Detaching toothed belt from camshaft	132
<b>3</b>	<b>Valve gear</b>	<b>137</b>
3.1	Assembly overview - valve gear	137
3.2	Measuring axial play of camshaft	140
3.3	Removing and installing camshaft oil seal	141
3.4	Removing and installing camshaft adjuster	143
3.5	Valve 1 for variable distribution N205 : removing and fitting	148
3.6	Checking hydraulic valve compensation elements	148
3.7	Removing and installing valve stem seals	149
<b>4</b>	<b>Inlet and exhaust valves</b>	<b>157</b>
4.1	Valve guides: verification	157
4.2	Valves: checking	158
4.3	Valve dimensions	158
<b>17</b>	<b>Lubrication</b>	<b>159</b>
<b>1</b>	<b>Sump, oil pump</b>	<b>159</b>
1.1	Exploded view - sump/oil pump	159
1.2	Engine oil	161
1.3	Removing and replacing oil sump	161
1.4	Oil pump: removing and installing	166
1.5	Removing and installing oil level and oil temperature sender G266	166
<b>2</b>	<b>Engine oil radiator</b>	<b>168</b>
<b>3</b>	<b>Oil filter, oil pressure switch</b>	<b>169</b>
3.1	Exploded view - oil filter housing/oil pressure switches	169
3.2	Removing and installing oil pressure switch F1	170
3.3	Removing and installing oil pressure switch for reduced oil pressure F378	171
3.4	Checking oil pressure	172
3.5	Removing and installing oil filter housing	172
3.6	Removing and installing valve for oil pressure control N428	174
<b>19</b>	<b>Cooling</b>	<b>176</b>
<b>1</b>	<b>Cooling system/coolant</b>	<b>176</b>
1.1	Connection diagram - coolant hoses	176
1.2	Checking cooling system for leaks	179
1.3	Draining and filling coolant	181

<b>2</b>	<b>Coolant pump/coolant thermostat</b>	<b>188</b>
2.1	Exploded view - coolant pump and thermostat	188
2.2	Exploded view - electric coolant pump	190
2.3	Exploded view - coolant temperature sensors	194
2.4	Removing and installing electric coolant pump	194
2.5	Removing and replacing coolant pump	203
2.6	Cooling system thermostat: removing and installing	204
2.7	Testing coolant thermostat	205
2.8	Removing and installing coolant valve for cylinder head N489	206
2.9	Removing and installing coolant temperature sender G62	206
<b>3</b>	<b>Coolant pipes</b>	<b>208</b>
3.1	Exploded view - coolant pipes	208
3.2	Removing and installing coolant pipes	209
<b>4</b>	<b>Radiator/radiator fans</b>	<b>224</b>
4.1	Exploded view - radiator/radiator fans	224
4.2	Exploded view - radiator cowl and radiator fans	229
4.3	Assembly overview - radiator blind	230
4.4	Removing and positioning radiator	233
4.5	Removing and installing cooler for charge air cooling circuit	239
4.6	Removing and installing radiator cowling with radiator fan	244
4.7	Removing and installing radiator fans	244
4.8	Removing and installing radiator blind	245
4.9	Removing and installing radiator blind control motor V544	247
<b>21 - Turbocharging/supercharging</b>		<b>252</b>
<b>1</b>	<b>Exhaust turbocharger</b>	<b>252</b>
1.1	Exploded view - turbocharger	252
1.2	Turbo compressor: removing and fitting	254
1.3	Renewing vacuum unit for turbocharger	270
1.4	Removing and installing connection for turbocharger	274
<b>2</b>	<b>Supercharger air system:</b>	<b>276</b>
2.1	Assembly overview - charge air system	276
2.2	Removing and installing charge pressure sender G31	278
2.3	Checking charge air system for leaks	278
2.4	Checking charge air cooler for leaks	280
<b>23 - Mixture preparation - injection</b>		<b>285</b>
<b>1</b>	<b>Injection system</b>	<b>285</b>
1.1	Schematic overview - fuel system	285
1.2	Overview of fitting locations - injection system	288
1.3	Filling and bleeding fuel system	293
1.4	Checking fuel system for leaks	294
<b>2</b>	<b>Vacuum system</b>	<b>295</b>
2.1	Connection diagram - vacuum system	295
2.2	Vacuum system: checking	295
<b>3</b>	<b>Injectors/high-pressure accumulator (rail)</b>	<b>297</b>
3.1	Assembly overview - injectors	297
3.2	Exploded view - high-pressure reservoir (rail)	299
3.3	Performing adaption of correction values for injectors	300
3.4	Checking injectors	300
3.5	Checking return flow rate of injectors with engine running	301
3.6	Checking return flow rate of injectors at starter cranking speed	304
3.7	Check the open nozzle units	306
3.8	Removing and installing injectors	308
3.9	Removing and installing high-pressure pipes	313

3.10	Removing and installing high-pressure reservoir (rail)	315
<b>4</b>	<b>Air cleaner</b>	<b>319</b>
4.1	Exploded view - air cleaner housing	319
4.2	Air filter housing: removing and fitting	320
<b>5</b>	<b>Suction pipe</b>	<b>323</b>
5.1	Exploded view - intake manifold	323
5.2	Removing and installing intake manifold	325
5.3	Throttle valve control unit J338 : removing and fitting	328
<b>6</b>	<b>Sensors</b>	<b>331</b>
6.1	Remove and install fuel pressure regulating valve N276	331
6.2	Checking fuel pressure regulating valve N276	337
6.3	Removing and installing fuel pressure sensor G247	338
6.4	Air mass meter G70 / intake air temperature sender G42 : Removal and installation	339
6.5	Removing and installing differential pressure sensor G505	341
6.6	Removing and installing exhaust gas pressure sensor 1 G450	345
6.7	Removing and installing charge air temperature sender ahead of charge air cooler G810	347
6.8	Removing and installing charge air temperature sender after charge air cooler G811	347
6.9	Removing and installing fuel temperature sender G81	347
<b>7</b>	<b>Engine control unit</b>	<b>350</b>
7.1	Removing and installing engine control unit J623	350
7.2	Removing and installing engine control unit J623 (with protective housing)	351
<b>8</b>	<b>High-pressure pump</b>	<b>356</b>
8.1	Exploded view - high-pressure pump	356
8.2	High-pressure pump: removing and fitting	357
<b>9</b>	<b>Lambda sensor</b>	<b>361</b>
9.1	Exploded view - Lambda probe	361
9.2	Removing and installing Lambda probe	362
<b>26</b>	<b>Exhaust system</b>	<b>366</b>
<b>1</b>	<b>Exhaust pipes/silencers</b>	<b>366</b>
1.1	Exploded view - silencers	366
1.2	Removing and installing front exhaust pipe with catalytic converter	378
1.3	Disconnecting exhaust pipes/silencers	379
1.4	Removing and installing rear silencer	382
1.5	Align exhaust system to be free of stress	383
1.6	Check exhaust system for leaks	384
<b>2</b>	<b>Emission control</b>	<b>385</b>
2.1	Assembly overview - emission control	385
2.2	Removing and installing catalytic converter	388
2.3	Removing and installing particulate filter	389
2.4	Removing and installing emission control module	390
2.5	Removing and installing exhaust flap control unit J883	410
<b>3</b>	<b>Exhaust gas temperature control</b>	<b>411</b>
3.1	Assembly overview - exhaust gas temperature regulation	411
3.2	Removing and installing exhaust gas temperature sensor 1 G235	413
3.3	Removing and installing exhaust gas temperature sender 2 G448	414
3.4	Removing and installing exhaust gas temperature sensor 3 G495	416
3.5	Removing and installing exhaust gas temperature sender 4 G648	417
<b>4</b>	<b>Exhaust gas recirculation</b>	<b>420</b>
4.1	Assembly overview - exhaust gas recirculation	420
4.2	Assembly overview - Control motor for exhaust gas recirculation V338	425
4.3	Removing and installing exhaust gas recirculation cooler	425
4.4	Removing and installing exhaust gas recirculation control motor V338	439

4.5	Removing and installing exhaust gas recirculation control motor 2 V339	440
4.6	Check seal integrity of exhaust recirculation cooler	441
<b>28</b>	<b>Glow plug system</b>	<b>443</b>
1	<b>Glow plug system</b>	<b>443</b>
1.1	Assembly overview - glow plug system	443
1.2	Removing and installing glow plug	444
1.3	Removing and installing automatic glow period control unit J179	446
1.4	Removing and installing Hall sensor G40	447
1.5	Removing and installing engine speed sensor G28	447



León 2013 ➤ , León ST 2013 ➤

4-cylinder diesel engine (1.6 l and 2.0 l 4V, TDI Common Rail, EA288) - Edition 02.2017

---

## 00 – Technical data

### 1 Safety instructions

(ERL003283; Edition 02.2017)

⇒ [“1.1 Safety precautions when working on fuel supply system”, page 1](#)

⇒ [“1.2 Safety precautions for working on vehicles with start-stop system”, page 1](#)

⇒ [“1.3 Safety precautions during road tests in which testing and measuring equipment is used”, page 2](#)

⇒ [“1.4 Safety precautions when working on the cooling system”, page 2](#)

#### 1.1 Safety precautions when working on fuel supply system

##### Risk of fire due to escaping fuel

If the battery is connected, the door contact switch will activate the fuel pump when the door is opened. Escaping fuel may ignite and cause a fire.

- Disconnect the fuel pump from the power supply before opening the fuel system.

##### Risk of injury due to highly-pressurised fuel.

The fuel system is pressurised. Injury possible due to fuel which may spurt out.

Before opening the fuel system:

- Use safety goggles.
- Wear protection gloves.
- Release pressure: place clean cloth around connection and carefully open connection.

##### Malfunction caused by air in the fuel supply system

Upon repair work on the fuel tank or the fuel delivery unit, air will be drawn in by the metering pump and conveyed to the auxiliary heater. Air in the fuel supply system may cause malfunction of the auxiliary heater.

- Fill fuel take-off pipe with fuel.

#### 1.2 Safety precautions for working on vehicles with start-stop system

##### Risk of injury due to unexpected engine start

In vehicles with activated Start/Stop system, the engine may start up unexpectedly. The status of the Start/Stop system is indicated by a message in the dash panel insert.

- Deactivate Start/Stop system by switching off the ignition.

### **1.3 Safety precautions during road tests in which testing and measuring equipment is used**

**There is a risk of injury due to unsafe test and measuring equipment.**

If a front passenger airbag is triggered during an accident, unsecured test and measuring equipment can become dangerous projectiles.

- Secure test and measuring equipment with seat belts on the rear seat.

Or

- Have a second person operate test and measuring equipment on the rear seat.

### **1.4 Safety precautions when working on the cooling system**

**Risk of scalding due to hot coolant**

The cooling system is under pressure when the engine is hot. Hot steam/hot coolant can escape - risk of scalding.

- Wear protection gloves.
- Use safety goggles.
- Reduce pressure by covering the cap of the coolant expansion tank with cloths and opening it carefully.



## 2 Identification

⇒ ["2.1 Engine identification number / engine data", page 4](#)

### 2.1 Engine identification number / engine data

- ◆ The engine number ("engine code" and "serial number") is located at the front at the joint between engine and gearbox -arrow-.
- ◆ Additionally there is a sticker on the toothed belt cover (top) with "engine code" and "serial number".
- ◆ Starting with the letter "C", the engine codes consist of 4 letters.
- ◆ The first 3 characters of the engine code stand for the engine capacity and the mechanical construction and design. They are stamped on the cylinder block, together with the serial number.
- ◆ The 4th character indicates the power output and torque of the engine, and is determined by the engine control unit.

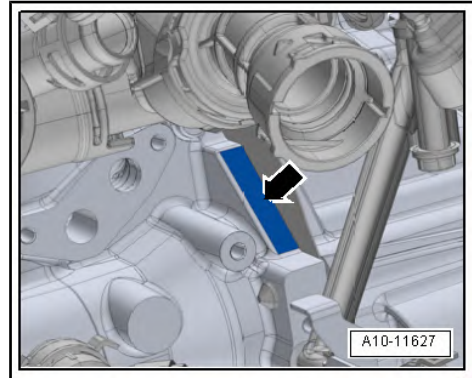

#### Note

- ◆ *The 4-character engine code can be found on the type plate (in versions for some countries only) and on the vehicle data sticker and the engine control unit.*
- ◆ *Fitting locations of the type plate (certain countries only) and the vehicle data sticker ⇒ Maintenance ; Booklet 501 .*

Code		CLHA	CLHB	CRKB	CXXA	CXXB
Exhaust emission standards as per		EU5 plus	EU5 plus	EU5 plus	EU6 plus	EU6 plus
Capacity	ltr.	1.598	1.598	1.598	1.598	1.598
Engine output	kW at rpm	77/3000 ... 4000	66/2750 ... 4800	81/3000 ... 4000	66/2750 ... 4800	81/3000 ... 4000
Torque	Nm at rpm	250/1500 ... 2750	230/1400 ... 2750	250/1400 ... 2750	230/1500 ... 2750	250/1500 ... 3000
Bore: Ø	mm	79.5	79.5	79.5	79.5	79.5
Stroke	mm	80.5	80.5	80.5	80.5	80.5
Compression ratio		16.2	16.2	16.2	16.2	16.2
Fuel type	according to	DIN EN 590	DIN EN 590	DIN EN 590	DIN EN 590	DIN EN 590
Ignition sequence		1-3-4-2	1-3-4-2	1-3-4-2	1-3-4-2	1-3-4-2
Exhaust gas recirculation		yes	yes	yes	yes	yes
Balance shafts		no	no	no	yes	yes
Exhaust gas temperature control		yes	yes	yes	no	no
Air charge		Exhaust turbocharger	Exhaust turbocharger	Exhaust turbocharger	Exhaust turbocharger	Exhaust turbocharger
Supercharging air refrigeration		yes	yes	yes	yes	yes
Lambda control		1 lambda sensors	1 lambda sensors	2 lambda probes	2 lambda probes	2 lambda sensors
Diesel particulate filter with catalytic converter		yes	yes	yes	yes	yes

Code	CLHA	CLHB	CRKB	CXXA	CXXB
SCR catalytic converter	no	no	no	no	no
Valves per cylinder	4	4	4	4	4

Code	CRBC	CRLB	CRLD	CKFB	CKFC
Exhaust emission standards as per	EU5 plus	EU6 plus	EU6 plus	EU5 plus	EU5 plus
Capacity ltr.	1.968	1.968	1.968	1.968	1.968
Engine output kW at rpm	110/3500 ... 4000	110/4000	81/3250 ... 4500	105/3500 ... 4000	110/3500 ... 4000
Torque Nm at rpm	320/1750 ... 3000	340/1750 ... 3000	250/1500 ... 3000	320/1750 ... 3000	320/1750 ... 3000
Bore: Ø mm	81.0	81.0	81.0	79.5	81.0
Stroke mm	95.5	95.5	95.5	81.0	95.5
Compression ratio	16.2	16.2	16.2	16.2	16.2
Fuel type according to	DIN EN 590	DIN EN 590	DIN EN 590	DIN EN 590	DIN EN 590
Ignition sequence	1-3-4-2	1-3-4-2	1-3-4-2	1-3-4-2	1-3-4-2
Exhaust gas recirculation	yes	yes	yes	yes	yes
Balance shafts	yes	yes	yes	no	no
Exhaust gas temperature control	yes	yes	yes	yes	yes
Air charge	Exhaust turbocharger	Exhaust turbocharger	Exhaust turbocharger	Exhaust turbocharger	Exhaust turbocharger
Supercharging air refrigeration	yes	yes	yes	yes	yes
Lambda control	1 lambda sensors	2 lambda probes	2 lambda probes	1 lambda sensors	1 lambda sensors
Diesel particulate filter with catalytic converter	yes	yes	yes	yes	yes

Code	CRBC	CRLB	CRLD	CKFB	CKFC
SCR catalytic converter	no	no	no	no	no
Valves per cylinder	4	4	4	4	4

Code	CRGA	CRVA	CRVC	CRMB	CUPA
Exhaust emission standards as per	EURO4	EURO4	EURO4	EU6 plus	EU5 plus
Capacity ltr.	1.968	1.968	1.968	1.968	1.968
Engine output kW at rpm	130/3500 0 ... 4000	81/3500 ... 4000	105/3,500 ...4,000	110/4000	135/3,500 ...4,000
Torque Nm at rpm	350/1750 0 ... 3000	250/1250 0 ... 2500	320/1,750 ... 3,000	340/1,750 ... 3,000	380/1,750 ... 3,000
Bore: Ø mm	81.0	81.0	81.0	81.0	81.0
Stroke mm	95.5	95.5	95.5	95.5	95.5
Compression ratio	16.2	16.2	16.2	16.2	15.8
Fuel type according to	DIN EN 590	DIN EN 590	DIN EN 590	DIN EN 590	DIN EN 590
Ignition sequence	1-3-4-2	1-3-4-2	1-3-4-2	1-3-4-2	1-3-4-2
Exhaust gas recirculation	yes	yes	yes	yes	yes
Balance shafts	yes	no	no	no	yes
Exhaust gas temperature control	Yes (reduced)	Yes (reduced)	Yes (reduced)	yes	yes
Air charge	Exhaust turbocharger	Exhaust turbocharger	Exhaust turbocharger	Exhaust turbocharger	Exhaust turbocharger
Supercharging air refrigeration	yes	yes	yes	yes	yes
Lambda control	1 lambda sensors	no,	no	2 lambda probes	1 lambda sensors
Diesel particulate filter with catalytic converter	Depending on variant	Depending on variant	Depending on variant	yes	yes

Code	CRGA	CRVA	CRVC	CRMB	CUPA
SCR catalytic converter	no	no	no	no	no
Valves per cylinder	4	4	4	4	4

Code		CUNA	DBKA	DCYA	DDYA	DDYB
Exhaust emission standards as per		EU6 plus	EU6 plus	EU6 plus	EU6 plus	EU6 plus
Capacity	ltr.	1.968	1.598	1.968	1.598	1.598
Engine output	kWh at rpm	135/3500 ... 4000	81/3250 ... 4000	110/3500 ... 4000	85/3250 ... 4000	66/3000 ... 4000
Torque	Nm at rpm	380/1750 ... 3000	380/1500 ... 3000	340/1750 ... 3000	250/1500 ... 3250	230/1500 ... 3000
Bore:	Ø mm	81.0	79.5	81.0	79.5	79.5
Stroke	mm	95.5	80.5	95,5Hub	80.5	80.5
Compression ratio		15.8	16.2	16.2	16.2	16.2
Fuel type	according to	DIN EN 590	DIN EN 590	DIN EN 590	DIN EN 590	DIN EN 590
Ignition sequence		1-3-4-2	1-3-4-2	1-3-4-2	1-3-4-2	1-3-4-2
Exhaust gas recirculation		yes	yes	yes	yes	yes
Balance shafts		yes	no	yes	no	no
Exhaust gas temperature control		yes	yes	yes	yes	yes
Air charge		Exhaust turbocharger	Exhaust turbocharger	Exhaust turbocharger	Exhaust turbocharger	Exhaust turbocharger
Supercharging air refrigeration		yes	yes	yes	yes	yes
Lambda control		2 lambda probes	2 lambda probes	1 lambda sensors	1 lambda sensors	1 lambda sensors

Code	CUNA	DBKA	DCYA	DDYA	DDYB
Diesel particulate filter with catalytic converter	yes	yes	yes	yes	yes
SCR catalytic converter	no	no	no	no	no
Valves per cylinder	4	4	4	4	4

## 3 Repair notes

⇒ [“3.1 Cleaning rules”, page 13](#)

⇒ [“3.2 Foreign particles in engine”, page 13](#)

⇒ [“3.3 Contact corrosion”, page 13](#)

⇒ [“3.4 Routing and attaching pipes and wiring”, page 14](#)

⇒ [“3.5 Installing radiators and condensers”, page 14](#)

### 3.1 Cleaning rules

The most insignificant contaminants can trigger malfunctions. You must therefore comply with the following cleanliness rules when working on the fuel supply system, injectors or the turbo-charger:

- ◆ Thoroughly clean all unions and surrounding areas with engine or brake system cleanser before disconnecting. Dry cleaned area thoroughly.
- ◆ Immediately seal open lines and connections with clean plugs, for example plugs from engine bung set - VAS 6122- .
- ◆ Place removed parts on a clean surface and cover them up. Use only lint-free cloths.
- ◆ Carefully cover or seal open components if repairs cannot be carried out immediately.
- ◆ Only install clean components; replacement parts should only be unpacked immediately prior to installation. Do not use parts that have not been stored in the proper packaging (e.g. in tool boxes etc.).
- ◆ When the system is open: Do not work with compressed air. Do not move vehicle unless absolutely necessary.
- ◆ Protect unplugged electrical connectors against dirt and moisture and make sure connections are dry when attaching.

### 3.2 Foreign particles in engine

To prevent the ingress of foreign bodies during work on the engine, seal all open connections. To do this, use suitable plugs from the engine bung set - VAS 6122- .



#### Note

*In the event of mechanical damage on turbocharger, observe ⇒ [page 254](#) .*

### 3.3 Contact corrosion

Contact corrosion can occur when using unsuitable connection elements (screws, nuts, washers ...).

For this reason only attachment elements with a special surface covering are used.

Moreover, certain rubber or plastic parts as well as adhesives made of electrically non-conductive materials.

If there is any doubt about the suitability of parts, a general rule is to use new parts ⇒ Electronic parts catalogue .

**Take into account:**

- ◆ Use genuine parts which are tested and compatible with aluminium.
- ◆ Use Seat accessories.
- ◆ Damage caused by contact corrosion is not covered under warranty.

### 3.4 Routing and attaching pipes and wiring

**There is a risk that the pipes and wiring may be damaged**

Lines may become damaged by moving or hot components.

- Route lines in their original positions.
- Ensure that there is sufficient clearance to moving or hot components.

### 3.5 Installing radiators and condensers

Even when the radiator, condenser and charge air cooler are correctly installed, slight impressions may be visible on the fins of these components. This does not mean that the components are damaged. If the fins are only very slightly distorted, this does not justify renewal of the radiator, charge air cooler or condenser.

## 10 – Removing and installing engine

### 1 Removing and installing the engine

⇒ [“1.1 Engine removal”, page 15](#)

⇒ [“1.2 Separating engine and gearbox”, page 34](#)

⇒ [“1.3 Securing engine to engine and gearbox support”, page 37](#)

⇒ [“1.4 Installing engine”, page 39](#)

#### 1.1 Engine removal



##### Note

*When installing a new base engine, it is essential that the clamping pieces for the injectors are tightened to the specified torque ⇒ [page 297](#) after installing the high-pressure pipes. The clamping pieces are only secured »hand-tight« at the factory so the injectors can be aligned during installation. Non-observance of these details may lead to damage to the engine*

#### Special tools and workshop equipment required

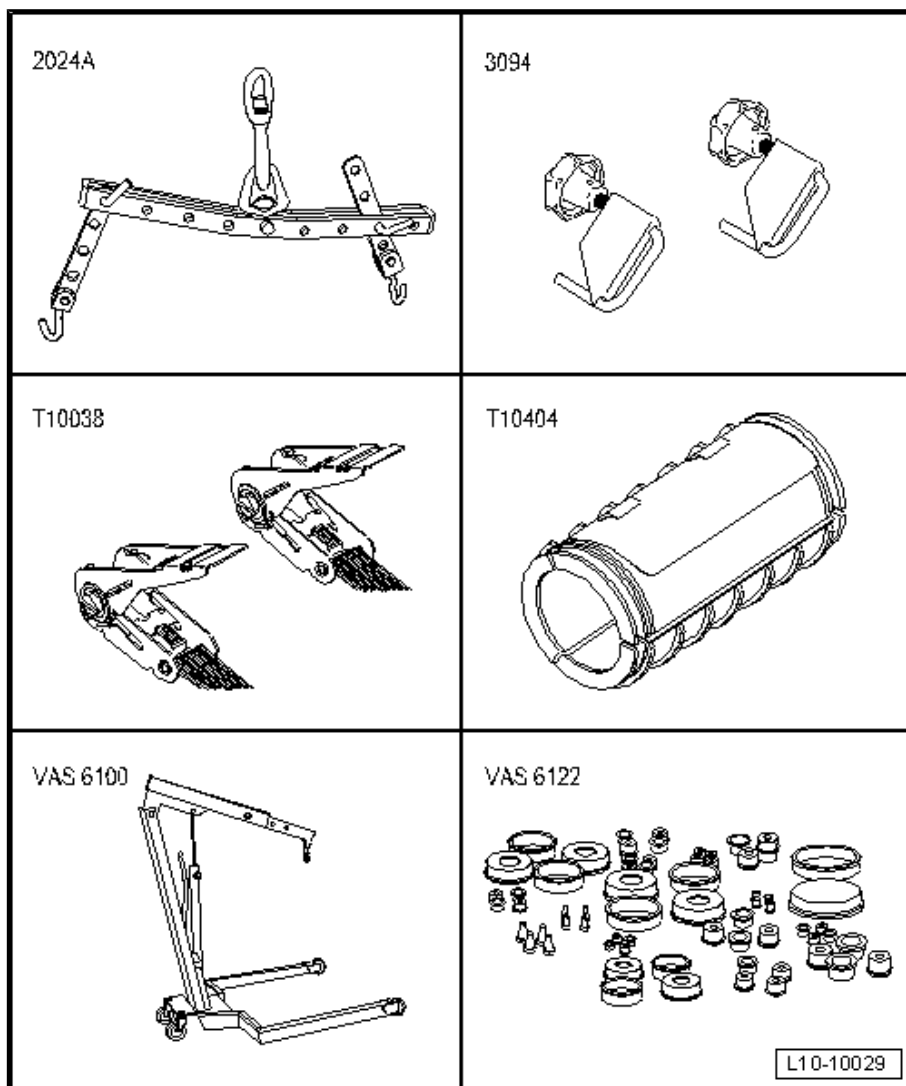

- ◆ Lifting tackle - 2024 A-
- ◆ Hose clips - 3094-
- ◆ Holding device - T10038-
- ◆ Transport lock - T10404-
- ◆ Workshop hoist - VAS 6100-

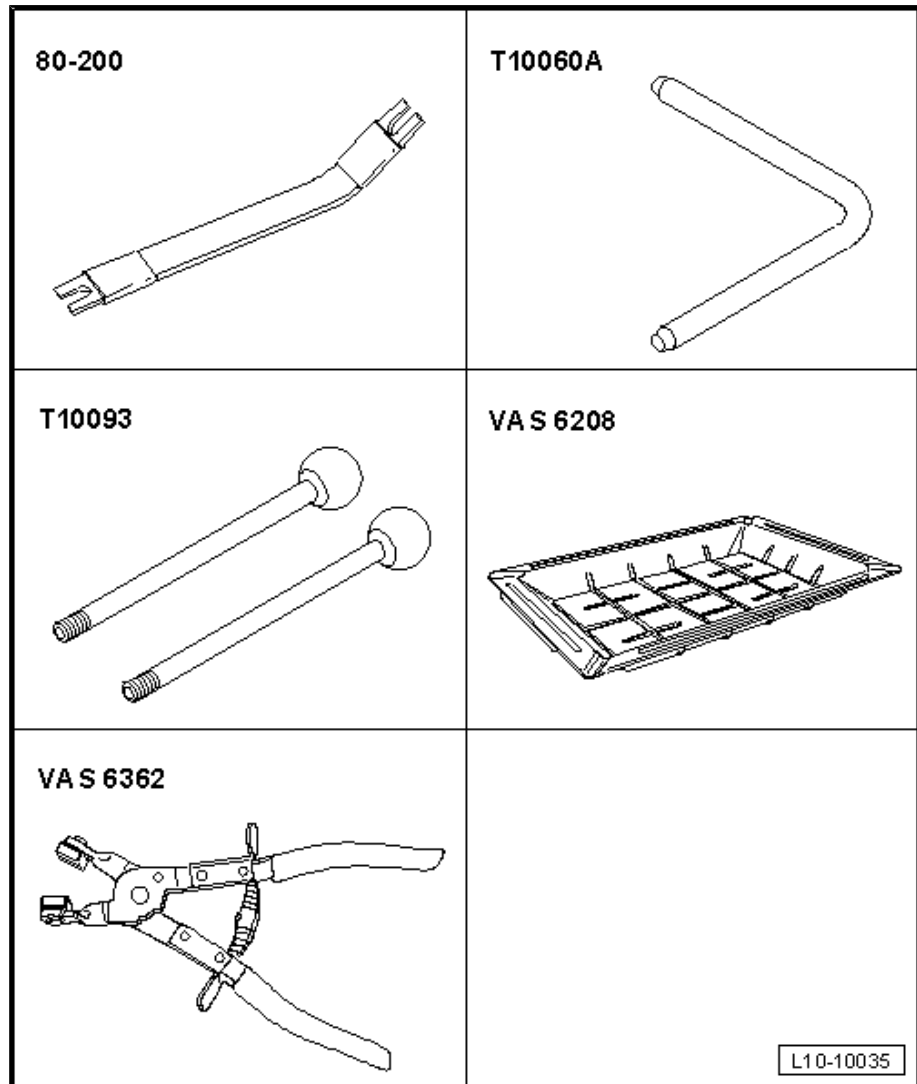

- ◆ Pressing-off lever - 80 - 200-
- ◆ Locking pin - T10060 A-
- ◆ Centre guide - T10093-
- ◆ Drip tray for workshop hoist - VAS 6208-
- ◆ Hose clip pliers - VAS 6362-

- ◆ Sealing cap set for engine - VAS 6122-

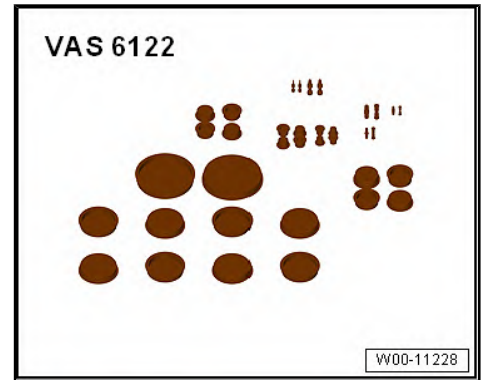

- ◆ Protective glasses
- ◆ Protective gloves

#### Operation process



- ◆ *The engine is removed upwards using the lifting tackle - 2024A- .*
- ◆ *After removing of coolant or fuel lines, these must be sealed using the engine sealing cap set - VAS 6122- to prevent dirt from entering or coolant or fuel from running out.*
- ◆ *Fit cable ties in the original positions when installing.*
- ◆ *Re-attach all heat insulation sleeves at the same locations when re-installing.*



#### WARNING

*Hot steam/hot coolant can escape - risk of scalding.*

- ◆ *The cooling system is under pressure when the engine is hot.*
- ◆ *Cover filler cap on expansion tank with a cloth and open carefully to dissipate pressure.*

- Open cap -arrow- on coolant expansion tank.
- Remove engine cover. ⇒ [page 56](#)
- For reasons of space, remove the air filter housing together with the intake hose ⇒ [page 321](#) .

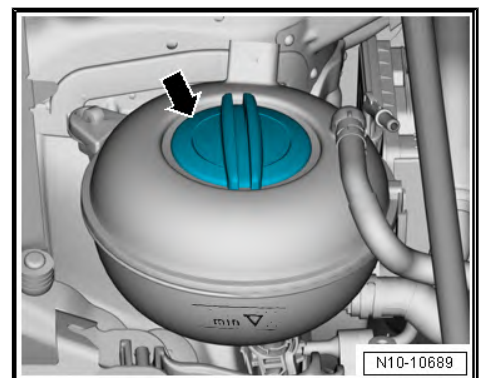

- Free coolant hose -3-.
- Remove screws -1-.
- Release locking lugs-arrow-, unclip air hose -2- from the front end and remove in -direction of the arrow-.
- Remove the battery tray ⇒ Electrical System; Rep. gr. 27 ; Battery; Disconnect and connect the battery .

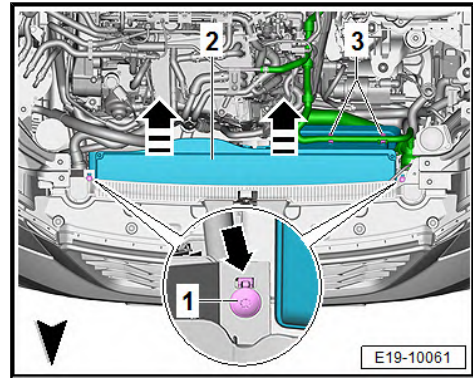

### Leon, Leon ST Variant 1

- Disconnect electrical connections, take cable out of the brackets and place over the engine.
- 2 - For exhaust gas temperature sender 4 - G648-
- 3 - For exhaust gas temperature sender 3 - G495-
- 4 - For Lambda probe 1 before catalytic converter - GX10- .

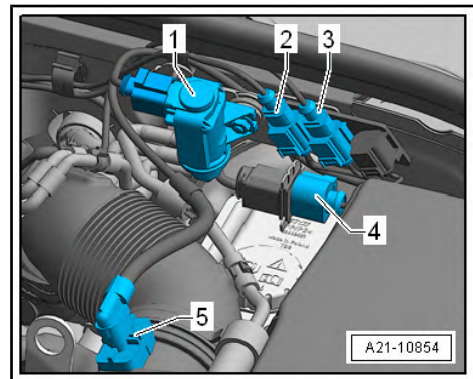

### Leon, Leon ST Variant 2

- Disconnect electrical connections, take cable out of the brackets and place over the engine.
- 1 - For exhaust gas temperature sender 4 - G648-
- 2 - For exhaust gas temperature sender 3 - G495-
- 3 - For exhaust gas temperature sender 2 - G448-
- 4 - For Lambda probe 1 before catalytic converter - GX10- .

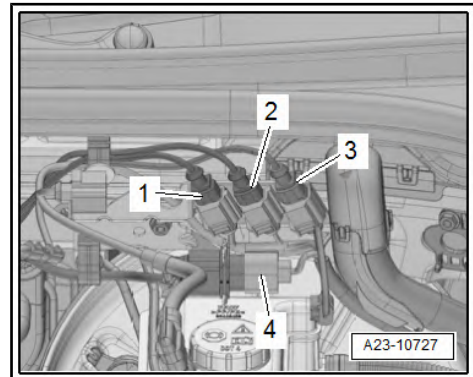

### All vehicles (continued):

- Detach vacuum hose -2- from vacuum unit of turbocharger.
- Disconnect vacuum hose -1- from T-piece.

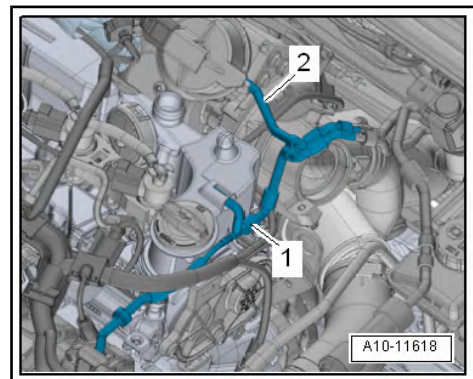

- Release catch -arrow- and disconnect vacuum hose -1-.
- Pull off vacuum hose -2-.

**i** Note

Item -3- can be disregarded.

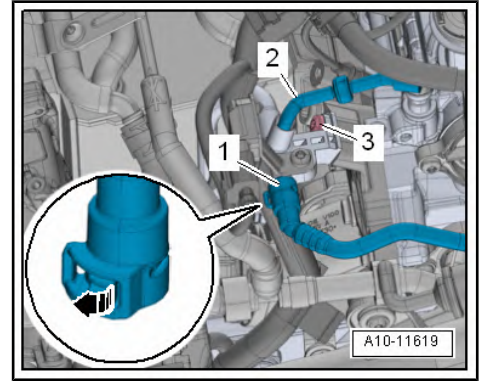

- Disconnect the electrical connection -2- of the engine control - J623- unit.
- Remove electrical connectors -1, 3, 4- from bracket and unplug.
- Remove engine control unit - J623- ⇒ [page 350](#) .

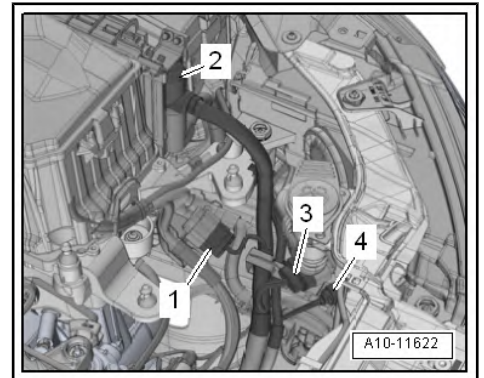

- Press release tabs -arrow-; Detach cover -1- for electronics box in engine compartment.

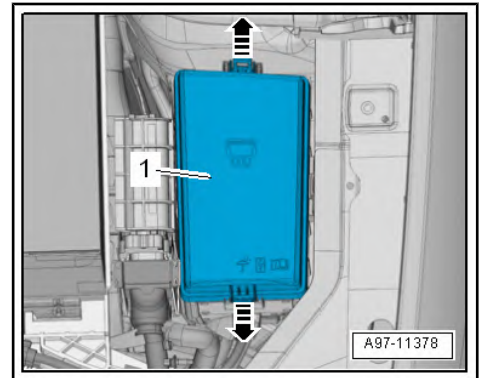

- Release catch using a screwdriver -arrow- and detach cover -1- for electronics box in engine compartment upwards.



- Remove nut -2- and screw -3- and disconnect electrical lines -arrow-.

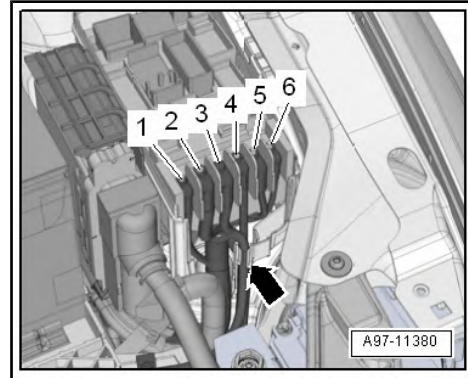

- Unscrew nut -arrow-; Remove bracket for engine control unit -1-.

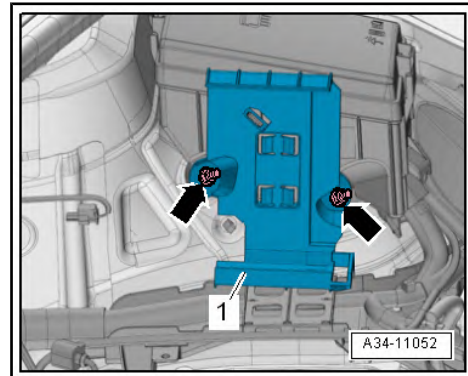

- Open cable duct -2- upwards -in the direction of arrow-, release fastening clip -1- for the lines.
- Release the requisite plug connections and clips.
- Remove line sections from the mounts and lay on the engine.

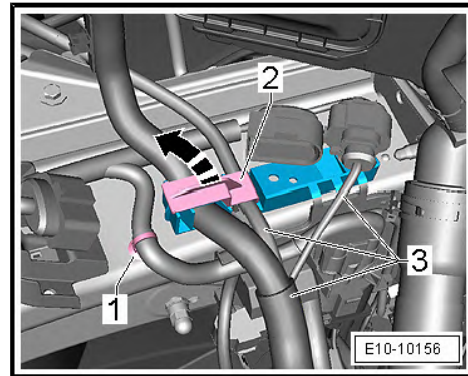

- Remove line guide -1- from its clips, slide upwards -in direction of arrow- and secure on one side.

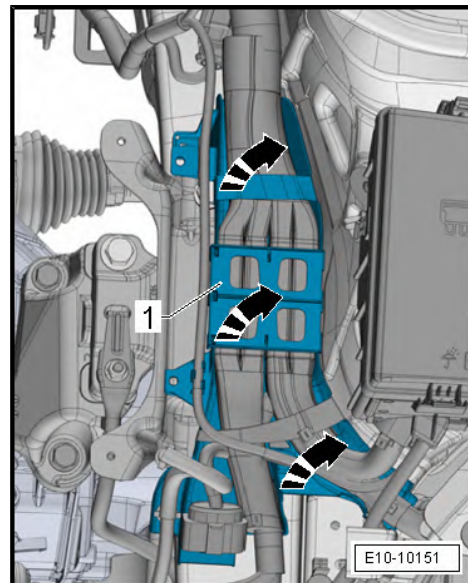

 **Note**

*Use removal lever - 80 - 200- to lever out the wiring clips when performing the next work steps.*

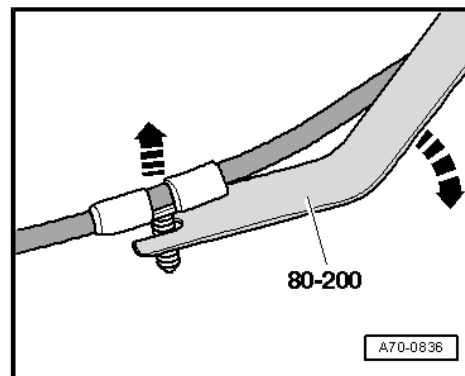

**Vehicles with manual gearbox 02S:**

- Dismantle the retaining washer -3- from the gearbox selector lever -1- and remove the cable -2- from the journal -arrow-.

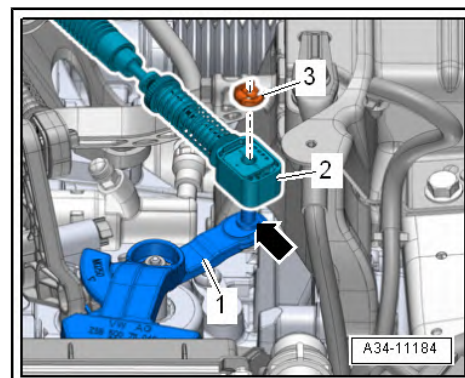

- Remove the clip -arrow 1- and then the selector lever together with the cable holder.

 **Note**

*Item -2- can be disregarded.*

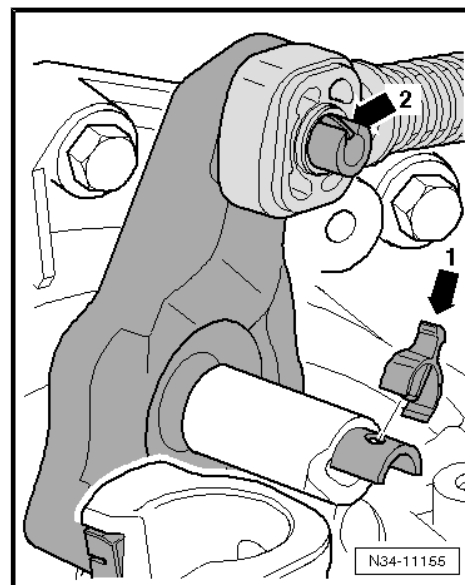

- Unscrew bolts -arrows -and place the cable support bracket to the side.

 **Note**

*As soon as the coupling slave cylinder is dismantled from the gearbox together with the connected hose line, the coupling pedal can no longer be engaged.*

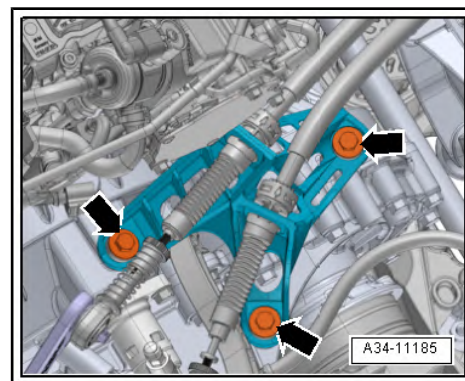

- Unscrew and remove bolts -Arrow B-; remove clutch slave cylinder and the hose and pipe line and set to one side.

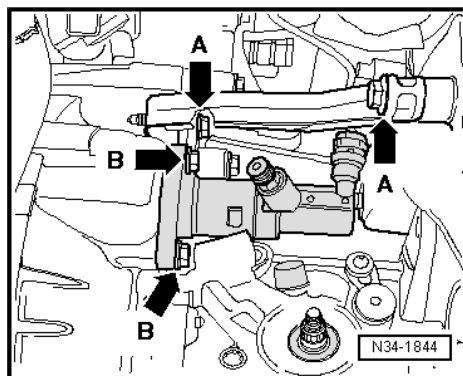

### Vehicles with dual clutch gearbox

6-speed dual clutch gearbox (0D9)

- Release rotary fastener of mechatronic unit connector -1- by turning it towards starter and pull off connector.

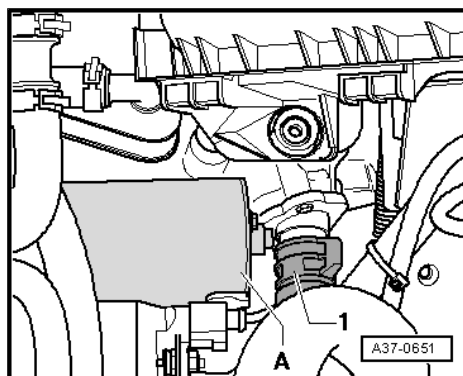

7-speed dual clutch gearbox (0CW)

#### Note

- ◆ Risk of damaging gearbox components.
- ◆ Do NOT touch connector contacts in gearbox connector with your hands. Electrostatic discharge can damage the control unit and mechatronics.

- Pull locking device upwards -arrow- and unplug electrical connector -1- for mechatronic unit for dual clutch gearbox - J743- .
- Unscrew earth cable on the bodywork.

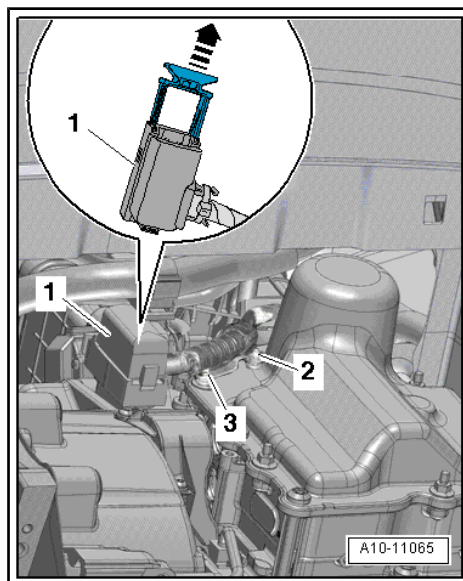

#### Note

- ◆ Risk of damaging selector lever cable.
- ◆ Do not bend or fold the selector lever cable.

- Pry ball socket -1- of selector lever cable off gearbox selector lever using removal lever - 80 - 200- .
- Remove bolts -2- and place selector lever cable with cable support bracket to side.
- Move the lines in the gearbox cover zone upwards and fix them in place.

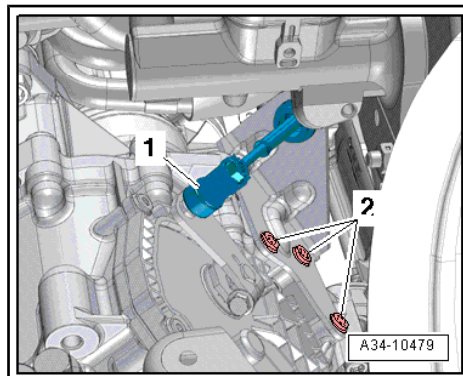

**Vehicles with manual gearbox 02Q:**

- Dismantle the retaining washer -3- from the gearbox selector lever -1- and remove the cable -2- from the journal -arrow-.

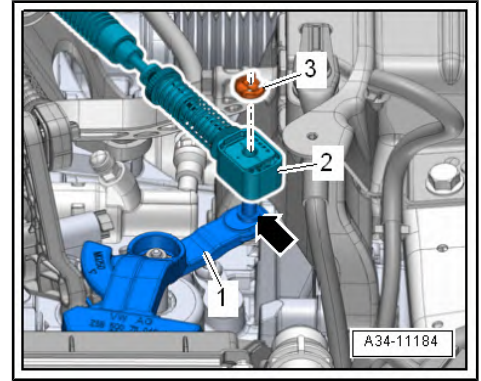

- Remove the clip -arrow 1- and then the selector lever together with the cable holder.

 **Note**

*Item -2- can be disregarded.*

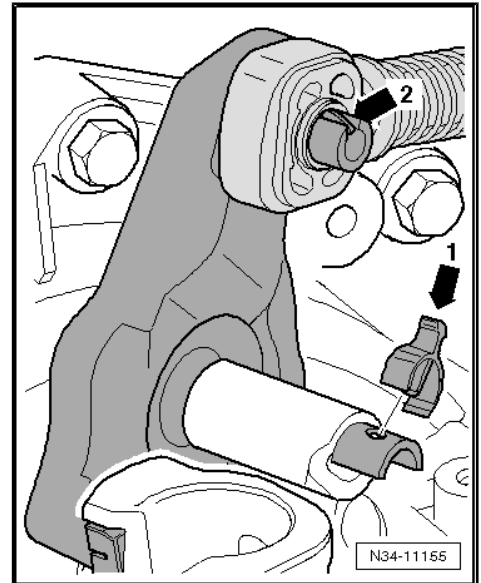

- Unscrew the nuts -1- and the bolts -2- and take off support and cables.

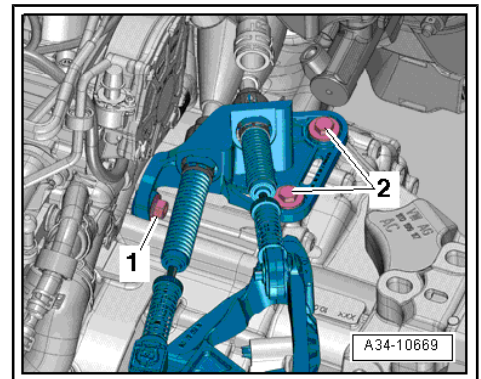

**i** Note

*When performing the following operations, care must be taken not to spill brake fluid onto the side member or gearbox. If fluid comes into contact with them, the affected area must be thoroughly cleaned.*

- Clamp off the supply hose from the clutch master cylinder with a hose clip -3094- .

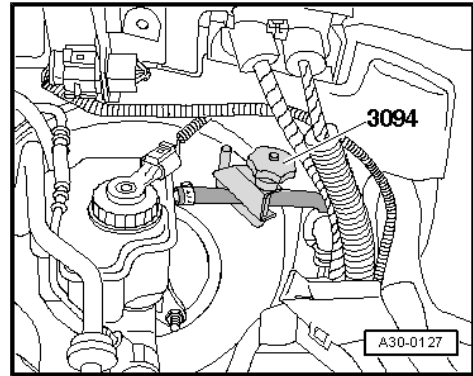

**i** Note

- ◆ *Clamping off the supply hose with the hose clamp - 3094- will cause a permanent deformation.*
- ◆ *However, this does not damage the supply hose.*
- ◆ *After removing the hose clip -3094- you must restore the supply hose to its original shape.*

- Place a lint-free cloth under the breather.
- Pull the safety clip -arrow- out as far as the stop and disconnect the pipe or hose -A- from the breather.

**i** Note

*-Item B- can be disregarded.*

- Seal open lines and connections with suitable plugs from the engine bung set - VAS 6122- .

**All vehicles (continued):**

- Set the lock carrier to its Service position => General body repairs, exterior; Rep. gr. 50 ; Lock carrier; Switching from and back to the Service position .
- Place drip tray for workshop hoist - VAS 6208- underneath.

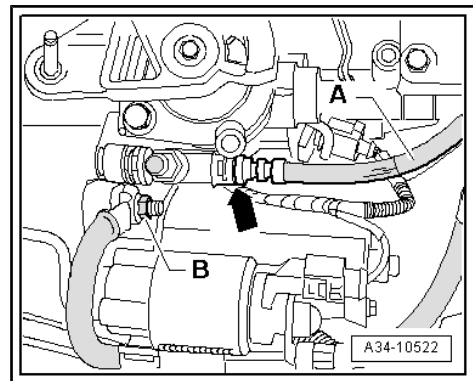

**i** Note

*Collect drained coolant in a clean container for re-use or disposal.*

**Vehicles with radiator, version 1:**

- Lift the retaining clip -arrow-, remove the coolant hose at the bottom left from the radiator, allow the coolant to drain off.

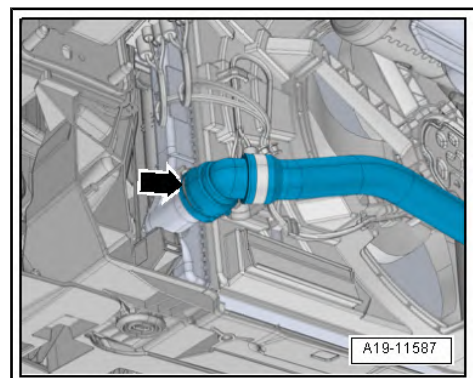

- Lift the retaining clip -arrow-, remove the coolant hose at the bottom right from the water radiator for the charge air cooling circuit, allow the coolant to drain off.

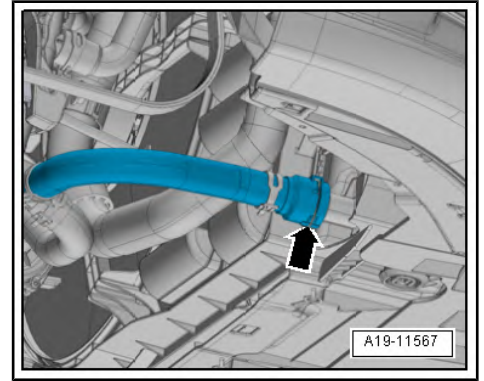

**Vehicles with radiator, version 2:**

- Lift the retaining clip -1-, remove the coolant hose at the bottom right from the radiator, allow the coolant to drain off.
- Lift the retaining clip -2-, remove the coolant hose at the bottom right from the water radiator for the charge air cooling circuit, allow the coolant to drain off.

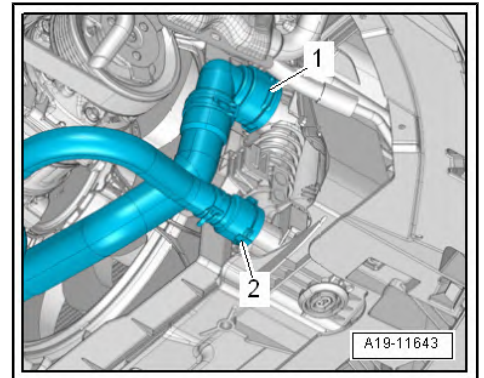

**Vehicles with radiator, version 3:**

- Lift the retaining clip -arrow-, remove the coolant hose at the bottom left from the radiator, allow the coolant to drain off.

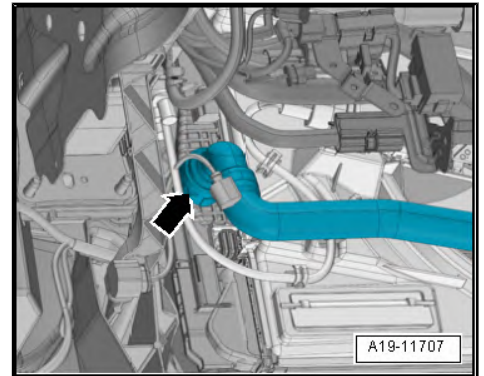

- Lift the retaining clips -1, 2-, remove the coolant hose at the bottom right from the water radiator for the charge air cooling circuit, allow the coolant to drain off.

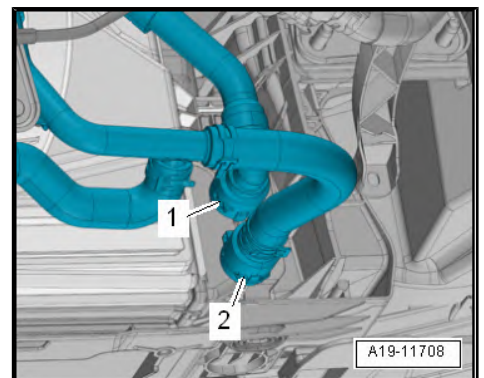

- Release fastener -arrow- and lift coolant hose -1- to detach.

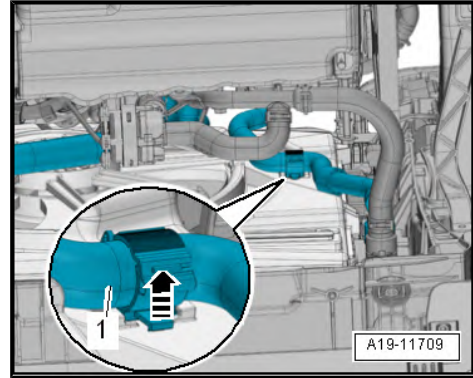

**All vehicles (continued):**

- Pull the electrical plug -3- from the reserve pump of the heater unit - V488- -2- .

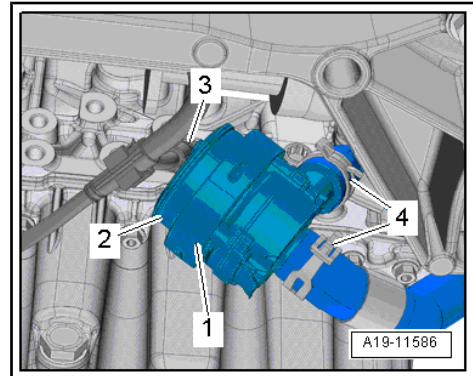

- Loosen the hose clip -arrow-, remove the lower coolant hose to the auxiliary pump for heating - V488- and allow the coolant to drain off.

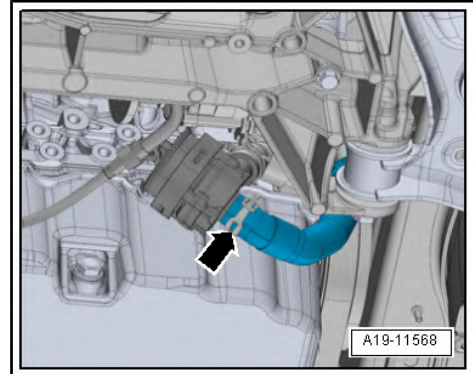

**Note**

*Place a cloth under heater heat exchanger to absorb escaping coolant.*

- Lift the retaining clips -arrows- and detach the coolant hoses from the heat exchanger for heater.
- Seal off open pipes/lines and connections immediately with clean plugs from engine sealing cap set - VAS 6122- .

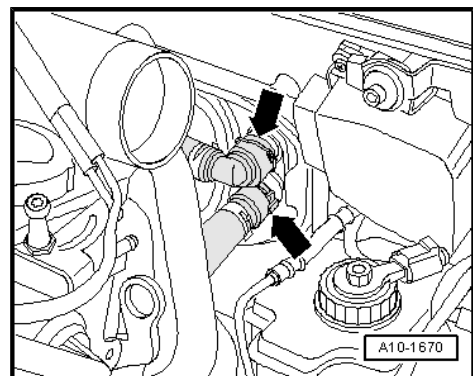

- Unplug electrical connector -5- from the fuel temperature sender - G81- .

 **Note**

*Item -2- can be disregarded.*

- Loosen the hose clips -4, 6- and remove the supply hose and return hose for fuel.
- Release hose clips -1, 3- and disconnect coolant hoses.

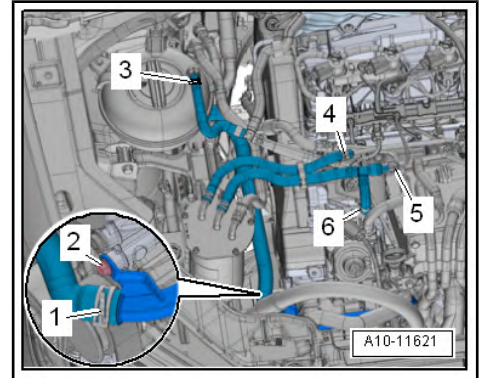

- Unplug the electrical connector -1-.
- Remove the holder -2- with the fuel hoses from the coolant expansion tank.
- Using a screwdriver, release fasteners -arrow- and move coolant expansion tank to one side.

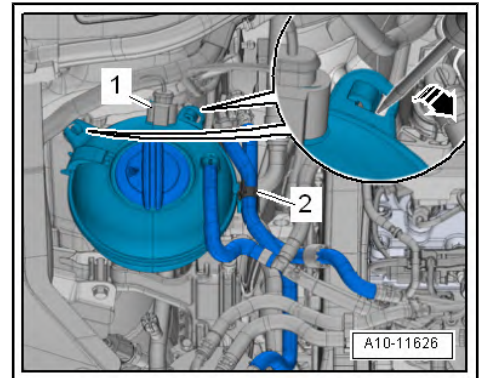

- Move clear bracket -3- with fuel hoses.
- Unscrew nut -2- and bolts -1-.
- Remove fuel filter -4-.

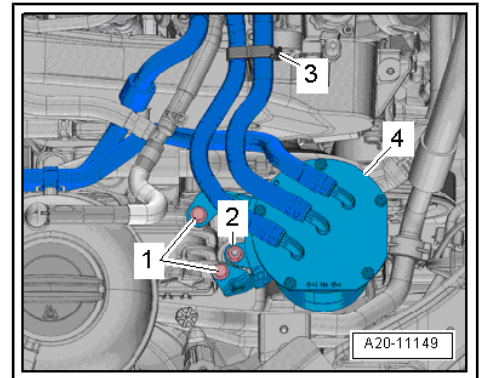

**Depending on model**

- Lift the retaining clip -arrow-, remove the coolant hose at the top right from the water radiator for the charge air cooling circuit.

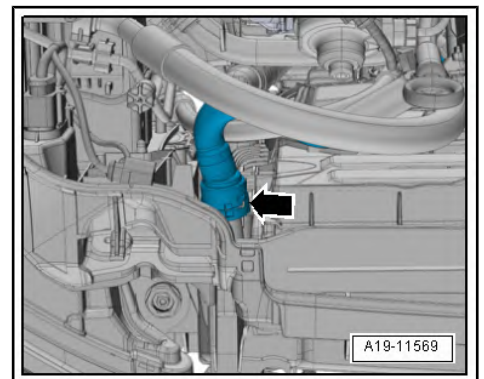

- Lift the retaining clip -arrow-, remove the coolant hose at the top left from the radiator.

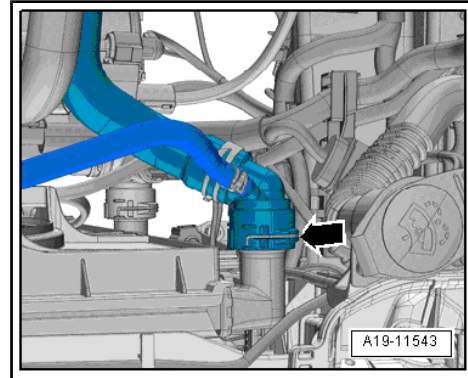

### Vehicles with air conditioner compressor

- Remove poly V-belt ➔ [page 59](#) .

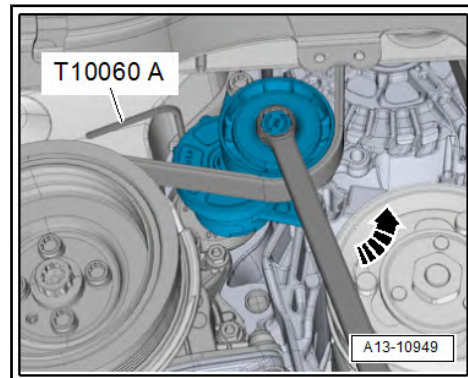

- Unplug the connector -1- at the air conditioner compressor regulating valve - N280- .



### WARNING

*Risk of injury caused by refrigerant.*

- ◆ *The air conditioner refrigerant circuit must not be opened.*

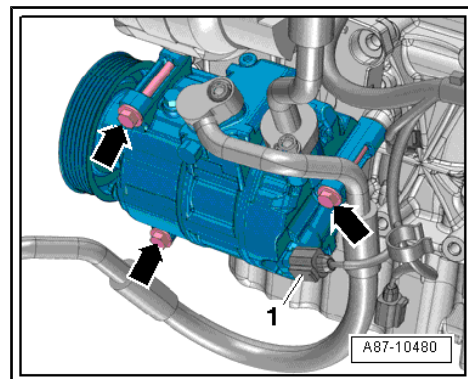

- Remove bolts -arrows-.



### Caution

*Make sure that air conditioner compressor and refrigerant pipes and hoses are not damaged!*

- ◆ *Do NOT stretch, kink or bend refrigerant lines and hoses.*

- Remove the air conditioning compressor together with the refrigerant hoses and bind to the right of the lock carrier with the tensioning belt - T10038- .

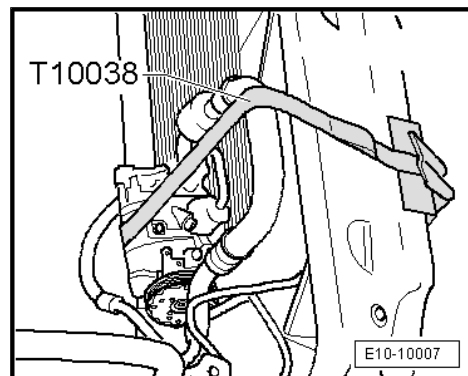

- Unplug electrical connector -arrow- at oil level and oil temperature sender - G266- .

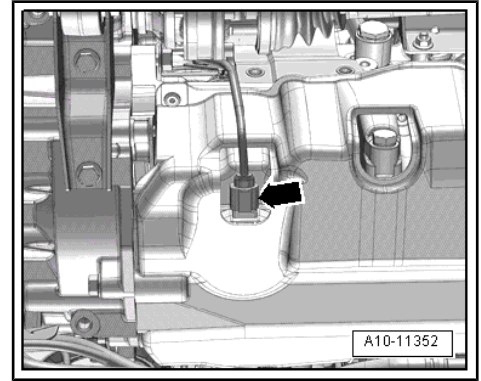

- Remove bolts -1, 2, 3- and detach pendulum support.

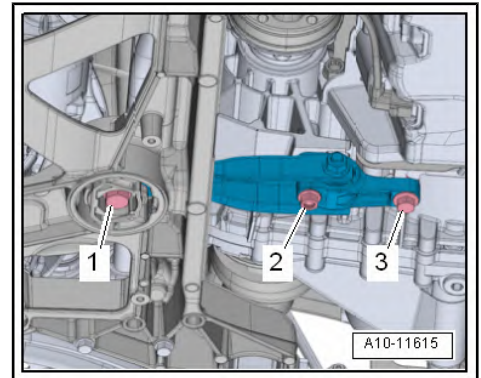

#### Vehicles with four-wheel drive

- If installed, remove screws -arrows- and remove the heat shield -1- .
- Removing the right-hand drive shaft => Running gear, axles, steering; Rep. gr. 40 ; Drive shaft; Removing and installing a drive shaft => Rep. gr. 40 ; Drive shaft; Removing and installing a drive shaft .

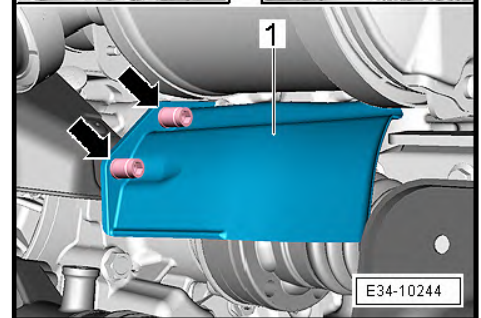
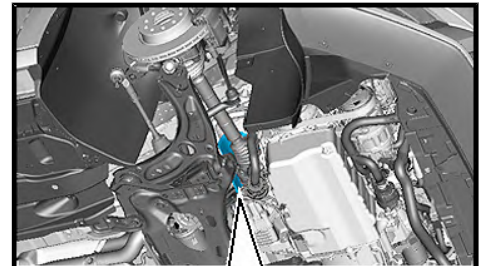

- Remove the drive shaft from the flange shaft / gear box -arrows- and support on the bracket.

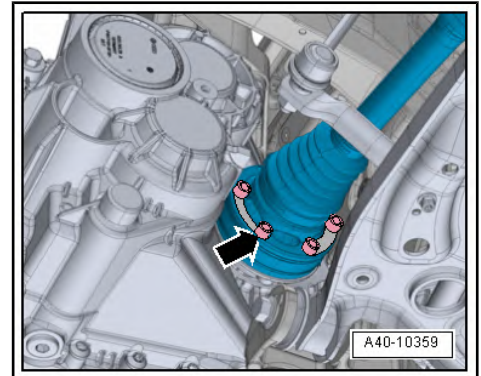

- Remove screws -A- and -B- from the bevel box and remove the heat shield -1- .

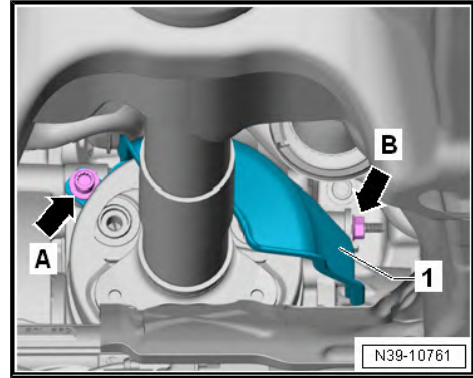

### Front-wheel drive vehicles

- If installed, remove bolts -1- and the heat guard.

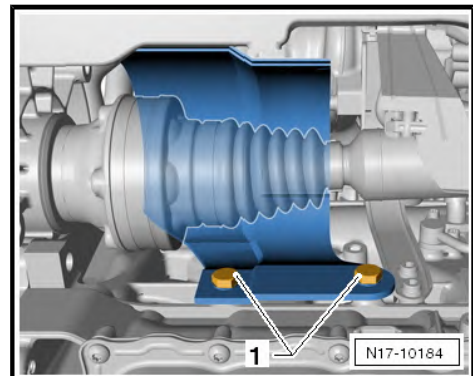

- Unscrew drive shafts from the flange shafts / gear box -arrow- and secure them up and back.



### Note

*Take care not to damage the surface coating of the drive shaft.*

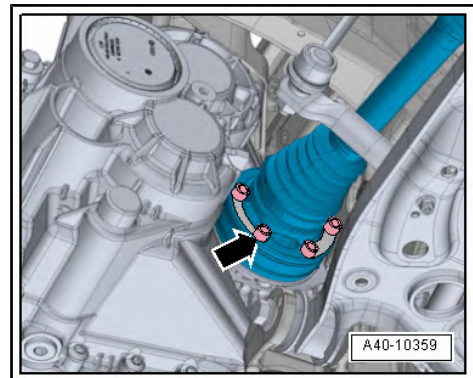

### All vehicles (continued):



### Note

*Never bend the damping element on the front section of the exhaust pipe more than 10°, otherwise it can be damaged.*

- Unplug electrical connector -1- from exhaust flap control unit -J883- .
- Loosen clamp -2- and push to rear.



### Note

- ◆ *Do not bend decoupling element more than 10°. It may be damaged*
- ◆ *Install decoupling element so that it is not under tension.*
- ◆ *Take care not to damage wire mesh on decoupling element.*
- ◆ *Do not remove protective packaging from replacement part until you are ready to fit the flexible joint*

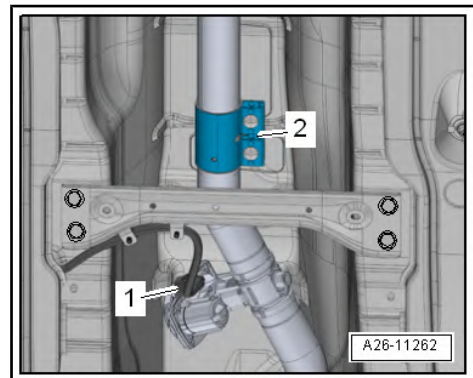

- Fit the transport lock - T10404- -arrow- on damping element on the front section of the exhaust pipe.

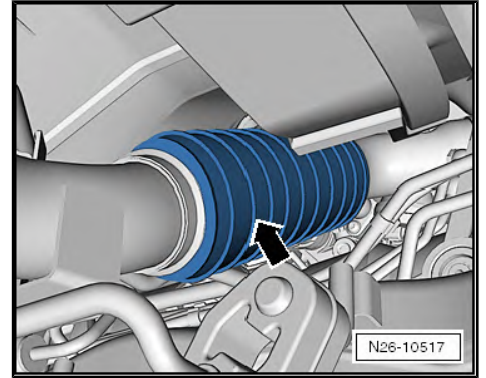

- Loosen bolt -2- and remove screw-type clip.
- Detach front exhaust pipe.

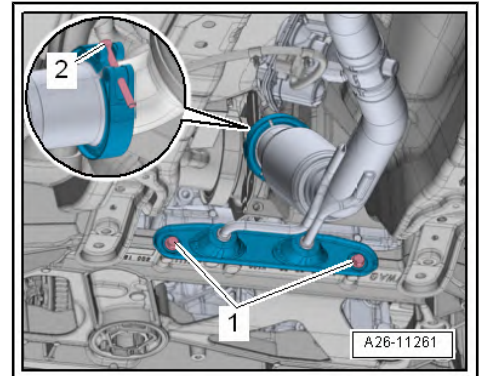

#### Vehicles with lambda probe 1 after catalytic converter - GX7-

- Unscrew both plastic nuts -arrows- from the left undercarriage panel -1- and move the panel slightly downward.

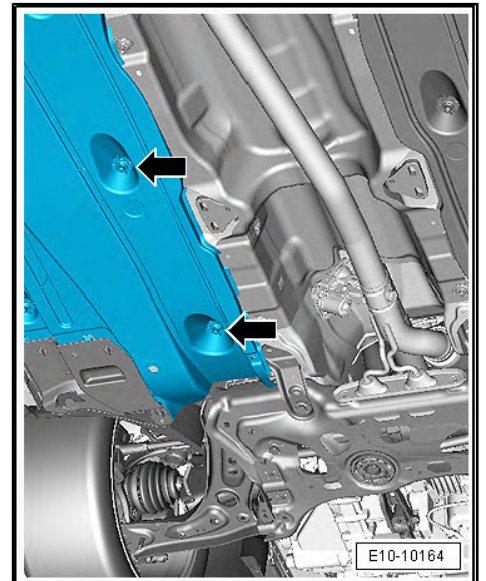

- Remove and disconnect connector -arrow- for Lambda probe 1 after catalytic converter - GX7- from retainer and lay wire to one side.

All vehicles (continued):



**Note**

- ◆ *Make sure that all lines of the exhaust temperature sender are not exposed to tension and that they are not damaged when removing the »engine assembly«.*
- ◆ *Check that all hose and line connections between engine, gearbox and body have been detached.*
- ◆ *If necessary, fasten the protruding coolant hoses and electric lines to the engine with flanges to prevent any damage.*

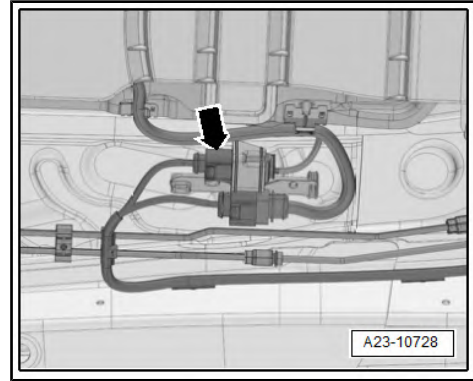

**Vehicles with four-wheel drive**

- Mark the position of the propshaft to the flange of the bevel box.

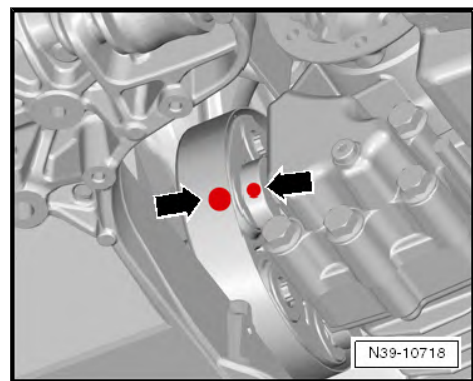

- Unscrew the bolts that hold the propshaft to the front bevel box -arrows- support the shaft on the triangular flange with a lever.



**Note**

- ◆ *Make sure not to damage the seal -arrow- in the propshaft flange.*
- ◆ *Push the propshaft horizontally to the rear and towards the left side of vehicle as far as possible.*

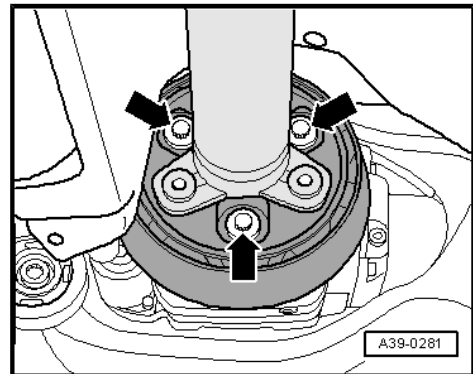

- When removing and placing the propshaft, always make sure that the shaft seal -arrow- is not damaged.
- Push the engine/gear box bracket a bit forward (in the direction of the front end) and separate the propshaft from the flange of the bevel box.

 **Note**

*The propshaft must be renewed if oil seal is damaged.*

- Lay the propshaft on the bracket, lay a cloth in between for protection and hold the shaft in a horizontal position.

**All vehicles (continued):**

 **Note**

*All periphery elements, such as electrical line sections, gear activators, coolant and vacuum lines, which could complicate the removal of the »engine/gear box assembly« should be ordered and secured with flanges.*

- Hook the suspension device - 2024A- as described in the following and, using the »workshop crane«, lift the engine assembly - VAS 6100- into its assembly position.

 **Note**

- ◆ Risk of damage to the vacuum lines or electrical wiring as well as damage to the engine compartment.
- ◆ Check that all vacuum lines and electrical wiring between engine, gearbox, subframe and body have been detached.
- ◆ Carefully remove the engine/gearbox unit out of the engine bay whilst lifting.

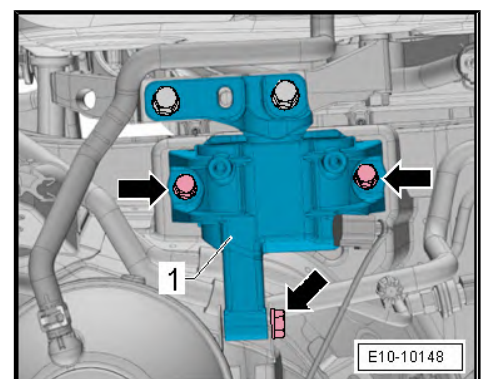
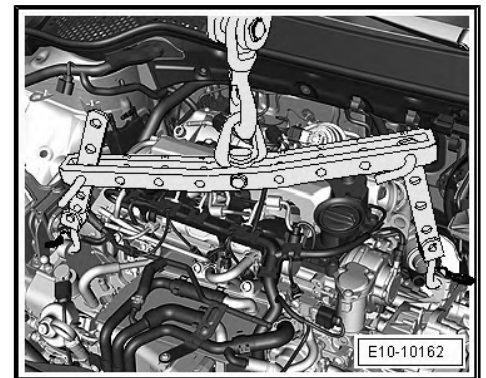
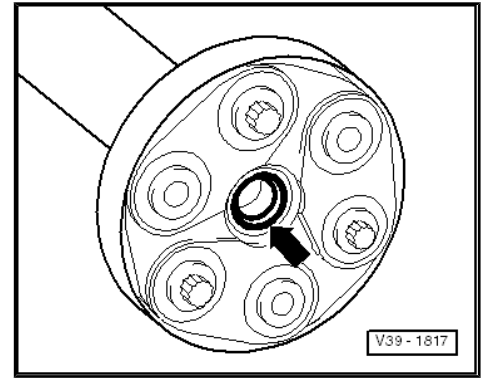

- Unscrew and remove the screws -Arrows- and remove engine mounting -1-.
- Unscrew bolts -arrows- on gearbox support -1-.



**Note**

*Different types of brackets are fitted depending on version.*



**Note**

*Carefully guide »engine/gearbox assembly« when removing to avoid damage to body.*

Secure engine to engine and gearbox support - VAS 6095- to carry out repairs ⇒ [page 37](#) .

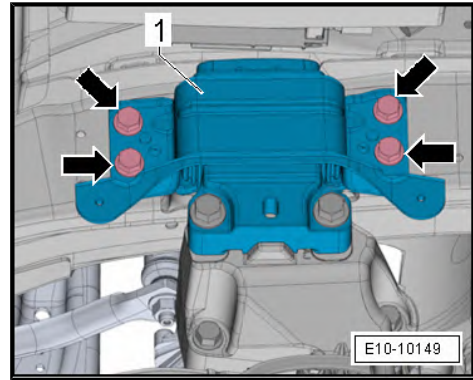

## 1.2 Separating engine and gearbox

⇒ ["1.2.1 Separating engine and gearbox - vehicles with manual gearbox", page 34](#)

⇒ ["1.2.2 Separating engine and gearbox, vehicles with dual clutch gearbox", page 36](#)

### 1.2.1 Separating engine and gearbox - vehicles with manual gearbox

Special tools and workshop equipment required

- ◆ Hooks - 10 - 222 A /2-

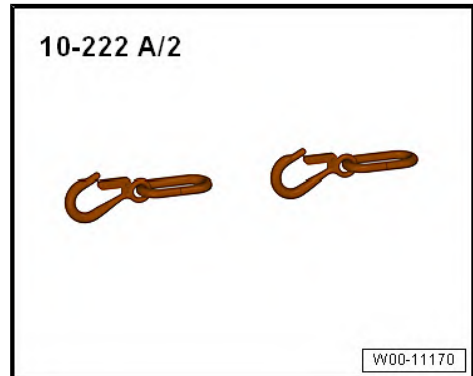

- ◆ Workshop hoist - VAS 6100-



◆ Lifting tackle - T40013-



**Operation process**

- Remove starter ⇒ Electrical system; Rep. gr. 27 ; Starter; Removing and installing starter
- Unscrew bolts -arrows- and detach gearbox support.

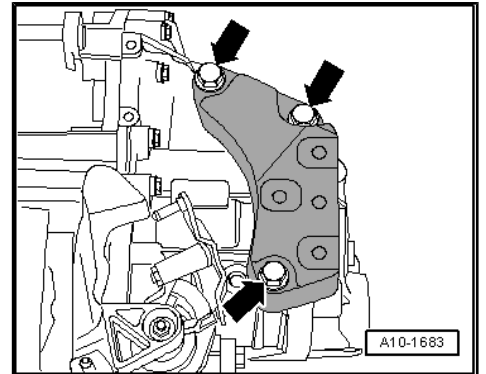

**Vehicles with four-wheel drive**

- Unscrew bolts -1, 2- remove the support for the angle gear.

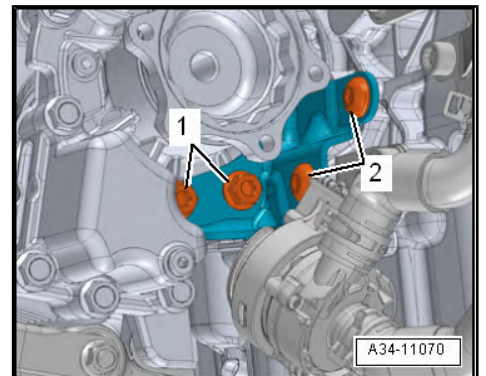

**All vehicles (continued):**

- Attach lifting tackle - T40013- to gearbox and close lock.
- Attach workshop crane - VAS 6100- with hooks - 10 - 222 A / 2- to lifting tackle.

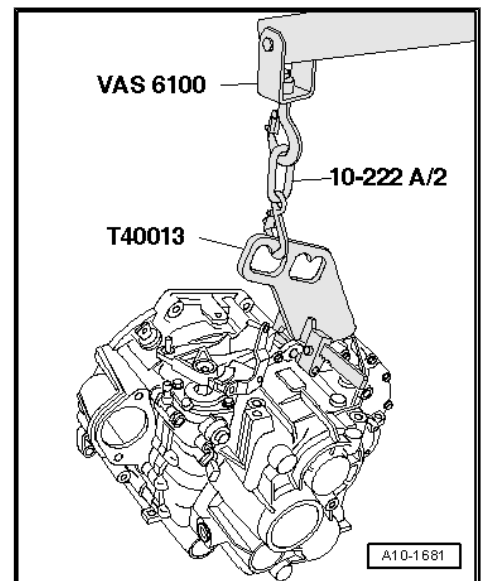

- Unscrew bolts -1, 2, 5, 6, 7, 8- from gearbox to engine connection.



**Note**

*Disregard -items 3, 4- and -A-.*

- Detach gearbox from engine (pay attention to intermediate plate).

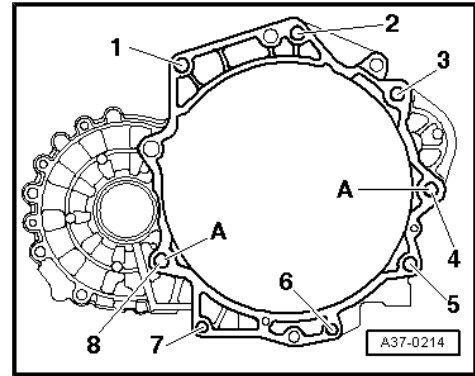

## 1.2.2 Separating engine and gearbox, vehicles with dual clutch gearbox

### Special tools and workshop equipment required

- ◆ Adapter - 10 - 222 A /20-



- ◆ Hook -2024 A /1- of lifting tackle - 2024 A-



- ◆ Workshop hoist - VAS 6100-



### Operation process

- Remove the coolant hoses from the gear oil cooler, to do this open the hose clips -arrows-.

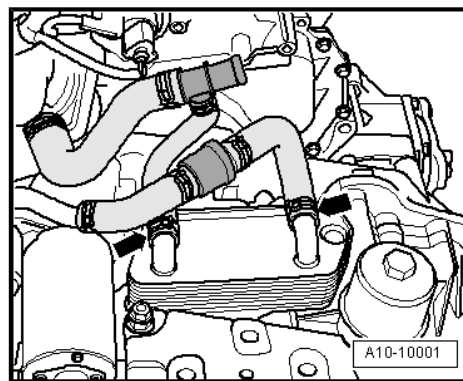

- Attach hook of lifting tackle - 2024 A- to gearbox lifting eye and secure with pin -arrow-.
- Attach workshop hoist - VAS 6100- with adapter - 10 - 222 A / 20- to hooks -2024 A /1- .

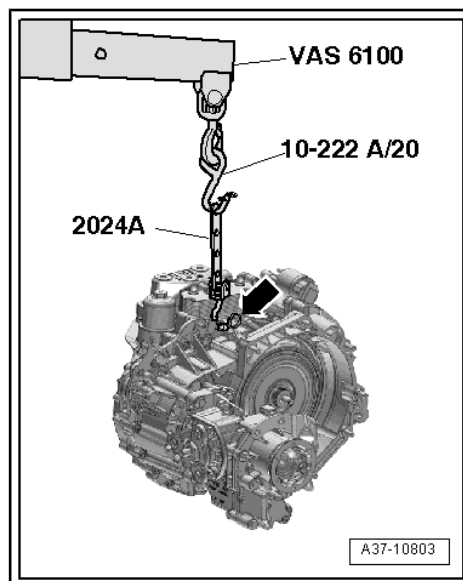

- Free wiring harnesses -arrows- and electrical connector -1- at bracket.

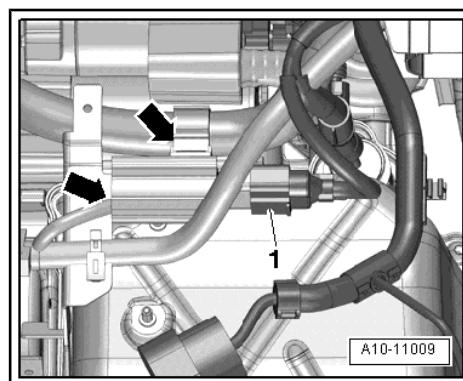

- Unscrew bolts -1- and -2- and remove starter from gearbox.
- Unscrew remaining bolts -1, 3, 5, 6, 7, 8, 9, 10- from gearbox to engine connection.

**i** Note

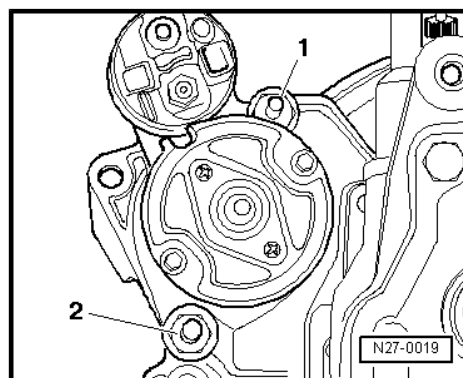

*Bolt -3- is only accessible after removing starter.*

- Detach gearbox from engine.

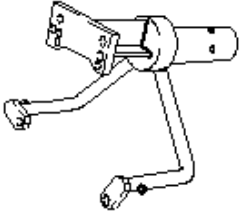
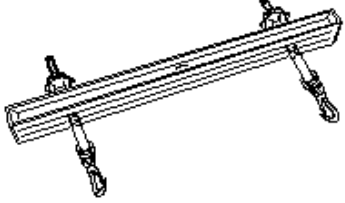
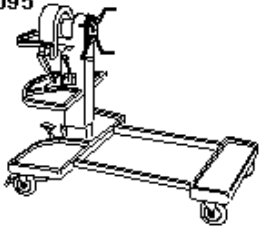

## 1.3 Securing engine to engine and gearbox support

**Special tools and workshop equipment required**

<p><b>VW 540</b></p> 	<p><b>3033</b></p> 
<p><b>VAS 6095</b></p> 	<p><b>VAS 6100</b></p> 
	<p style="text-align: right;">G10-0074</p>

- ◆ Engine and gearbox support - VW 540-
- ◆ Lifting tackle - 3033-
- ◆ Engine and gearbox support - VAS 6095-
- ◆ Workshop hoist - VAS 6100-

**Operation process**

- With the gearbox separated from the engine ⇒ [page 34](#) .

– Engage lifting tackle - 3033- as follows:

Position 3 - Flywheel end

Position 9 - Vibration damper end

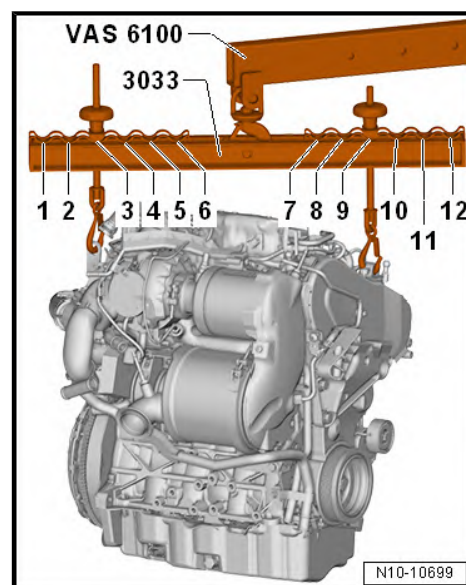

– Secure engine to engine and gearbox support - VW 540- using engine and gearbox support - VAS 6095- .



## 1.4 Installing engine



### Caution

*When installing a new base engine, it is essential that the clamping pieces for the injectors are tightened to the specified torque ⇒ [page 297](#) after installing the high-pressure pipes. The clamping pieces are only secured »hand-tight« at the factory so the injectors can be aligned during installation. Non-observance of these details may lead to damage to the engine*



### Note

- ◆ After new components have been installed (engine/short engine, cylinder head, camshaft housing or turbocharger) the oil pressure control must be set to max. pressure for approx. 1,000 km. This will compensate for the increased friction during run-in of new components, and a better transport of wear-related particles is guaranteed. To do this, connect vehicle diagnostic and service information system, switch on ignition and select the following menu item:

- ◆ Oil pressure for entry in the engine



**Note**

*Depending on the vehicle, the engine and the firmware version of the vehicle diagnostic and service information system, the specified path may vary slightly.*

Component		Nm
Nuts/bolts	M6	10
	M7	15
	M8	20
	M10	40
	M12	65

- ◆ Assembly mountings  
⇒ ["2.1 Exploded view - assembly mountings", page 44](#) .
- ◆ Securing the gearbox to engine ⇒ Rep. gr. 34 ; Gearbox: removing and installing; Gearbox: installing .

**Operation process**

- Attach power unit with the aid of the lifting device - 2024 A- and the workshop crane - VAS 6100- .



**Note**

- ◆ *Renew the bolts tightened with specified tightening angle.*
  - ◆ *Renew self-locking nuts and bolts as well as gaskets, seals and O-rings.*
  - ◆ *Hose unions and air intake pipes/hoses must be free of oil and grease when installing.*
  - ◆ *Secure hose unions with hose clamps the same as those of the series ⇒ [Electronic parts catalogue](#) .*
  - ◆ *Fit cable ties in the original positions when installing.*
- Intermediate plate installation ⇒ [page 68](#)

- If there are no dowel sleeves -A- in cylinder block for centring engine and gearbox, insert new ones.

**i** Note

*A vehicle with manual gearbox is shown in the illustration as an example.*

**Vehicles with manual gearbox**

- Remove needle bearing in crankshaft if fitted ⇒ [page 78](#) .
- If clutch release bearing is worn, renew it ⇒ Rep. gr. 30 ; Clutch mechanism; Repairing clutch release mechanism .
- Lightly grease gearbox input shaft splines with grease for clutch plate splines ⇒ Electronic Parts Catalogue .
- Make sure that clutch plate is properly centred.

**Vehicles with dual clutch gearbox**

- Install needle bearing if not fitted in crankshaft ⇒ [page 78](#) .

**Vehicles with four-wheel drive**

- Assemble the shaft support for the bevel box ⇒ Rep. gr. 34 ; Angle gear .

**All vehicles (continued):**

- Secure gearbox to engine.
- Install gearbox support.

The engine/gearbox unit is inserted into the engine compartment with the assembled engine and gearbox supports.

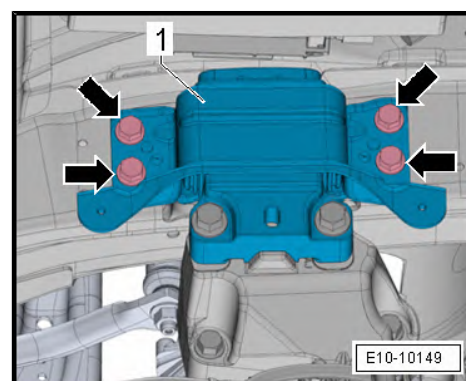
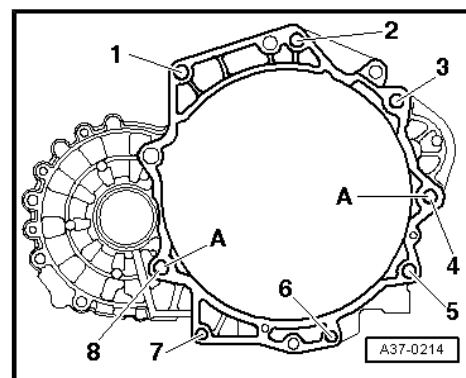

- Screw in bolts -arrows- by hand until stop in the gearbox support -1-.
- Screw in bolts -arrows- by hand until stop in the engine bracket -1-.



**Note**

*Different types of brackets are fitted depending on version.*

- Using the lifting tackle - 2024 A- and the workshop crane - VAS 6100- insert the engine/gearbox unit.

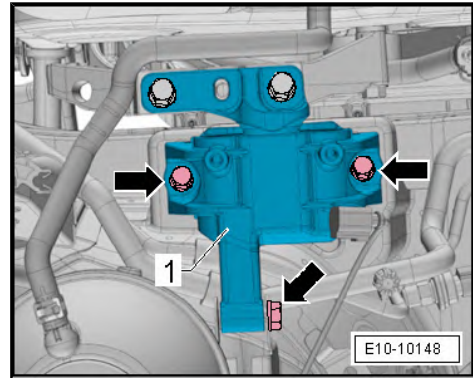

**Vehicles with four-wheel drive**



**Note**

*Make sure that the propshaft is not damaged.*

**All vehicles (continued):**

- Move the engine/gearbox assembly alongside the body. Please note that this assembly is initially supported by the gearbox mounting on the longitudinal member.



**Note**

*Attach drive shafts to corresponding flange shafts of gearbox.*



**Note**

*The bolts are tightened to final torque only after adjusting the assembly mountings ⇒ [page 54](#) .*

- Install starter ⇒ Electrical system; Rep. gr. 27 ; Starter; Starter: assembly overview .
- Install air intake pipe ⇒ [page 276](#) .
- Installing intake pipe ⇒ [page 252](#) .
- Install the exhaust pipe ⇒ [page 378](#) .
- Install drive shafts ⇒ Running gear, axles, steering; Rep. gr. 40 ; Drive shaft; Assembly overview - drive shaft .
- Install heat shield for the drive shaft, tightening torque 25 nm.

**Vehicles with four-wheel drive**

- Screw the propshaft to the forward bevel box ⇒ Rep. gr. 39 ; Propshaft; assembly overview - Propshaft

- Attach heat guard -1- to the bevel box.

#### Tightening torque:

- ◆ Bolt -A- 20 Nm
- ◆ Bolt -B- 40 Nm
- Install heat guard for the drive shaft, torque 20 nm.

#### All vehicles (continued):

- Installing pendulum support ⇒ [page 51](#)
- Install air conditioner compressor ⇒ Rep. gr. 87 ; Air conditioner compressor; Exploded view - air conditioner compressor drive group .
- Fit poly V-belt ⇒ [page 59](#) .
- Install engine control unit ⇒ [page 350](#) .
- Remove clutch slave cylinder ⇒ Rep. gr. 30 ; Clutch mechanism; Removing and installing clutch slave cylinder .
- Bleed clutch line ⇒ Rep. gr. 30 ; Clutch mechanism: bleed .
- Installing control cables with counter-hold tool ⇒ Rep. gr. 34 ; Selector mechanism; Control cables: assembly overview .
- Adjust the mechanical group mountings ⇒ [page 54](#) .
- Install battery tray ⇒ Electrical system; Rep. gr. 27 ; Battery; Battery: assembly overview .
- Electrical connections and routing ⇒ Electrical system; Rep. gr. 97 ; Relay carriers, fuse carriers, electronics boxes; Overview of fitting locations - relay carriers, fuse carriers, electronics boxes and ⇒ Current flow diagrams, Electrical fault finding and Fitting locations.
- Connect vacuum hoses ⇒ [page 295](#) .
- Connect coolant hoses with plug couplings to the heat exchanger for heating ⇒ [page 228](#)
- Install the air cleaner housing ⇒ [page 320](#) .

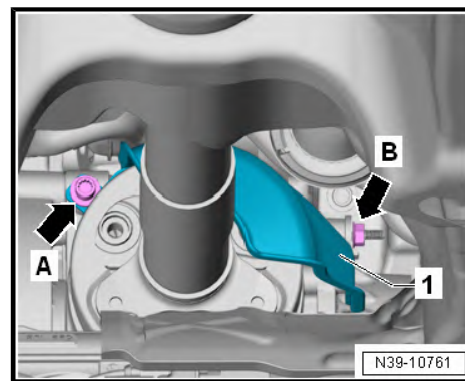

#### Note

- ◆ *Never use battery charging equipment for boost starting.*
- ◆ *Overvoltage can cause irreparable damage to control units.*
- Install the lock carrier to its Service position ⇒ General body repairs, exterior; Rep. gr. 50 ; Lock carrier; Assembly overview - Lock carrier .
- Bleeding the fuel system ⇒ [page 293](#) .

#### Note

*Do not reuse the used coolant.*

- Replenish coolant ⇒ [page 184](#) .
- check oil level ⇒ Maintenance ; Booklet 501 .

Erase the entries in the event memory ⇒ Vehicle diagnostic tester, Guided Functions, Reading out event memory.

## 2 Engine/gearbox mountings

⇒ [“2.1 Exploded view - assembly mountings”, page 44](#)

⇒ [“2.2 Removing and installing engine mountings”, page 45](#)

⇒ [“2.3 Removing and installing gearbox mounting”, page 46](#)

⇒ [“2.4 Removing and installing pendulum support”, page 49](#)

⇒ [“2.5 Supporting engine in installation position”, page 51](#)

⇒ [“2.6 Adjusting assembly mounting”, page 54](#)

⇒ [“2.7 Checking adjustment of assembly mountings”, page 55](#)

### 2.1 Exploded view - assembly mountings

#### 1 - Bolt.

- Renew
- Tightening sequence  
⇒ [page 64](#)

#### 2 - Engine support

- Removing and fitting  
⇒ [page 63](#)

#### 3 - Engine bracket

- Removing and fitting  
⇒ [page 45](#)
- Set aggregates bearing  
⇒ [page 54](#)
- With support arm

#### 4 - Bolt.

- Renew
- 40 Nm + turn +90° further

#### 5 - Bolt.

- Renew
- 20 Nm + turn +90° further

#### 6 - Bolt.

- Renew
- 40 Nm + turn +90° further

#### 7 - Bolt.

- Renew
- 60 Nm + turn +90° further

#### 8 - Pendulum support

- Removing and fitting ⇒ [page 49](#)

#### 9 - Bolt.

- Renew
- Tightening torque and sequence ⇒ [page 51](#) .

#### 10 - Bolt.

- Renew
- Tightening torque and sequence ⇒ [page 51](#) .

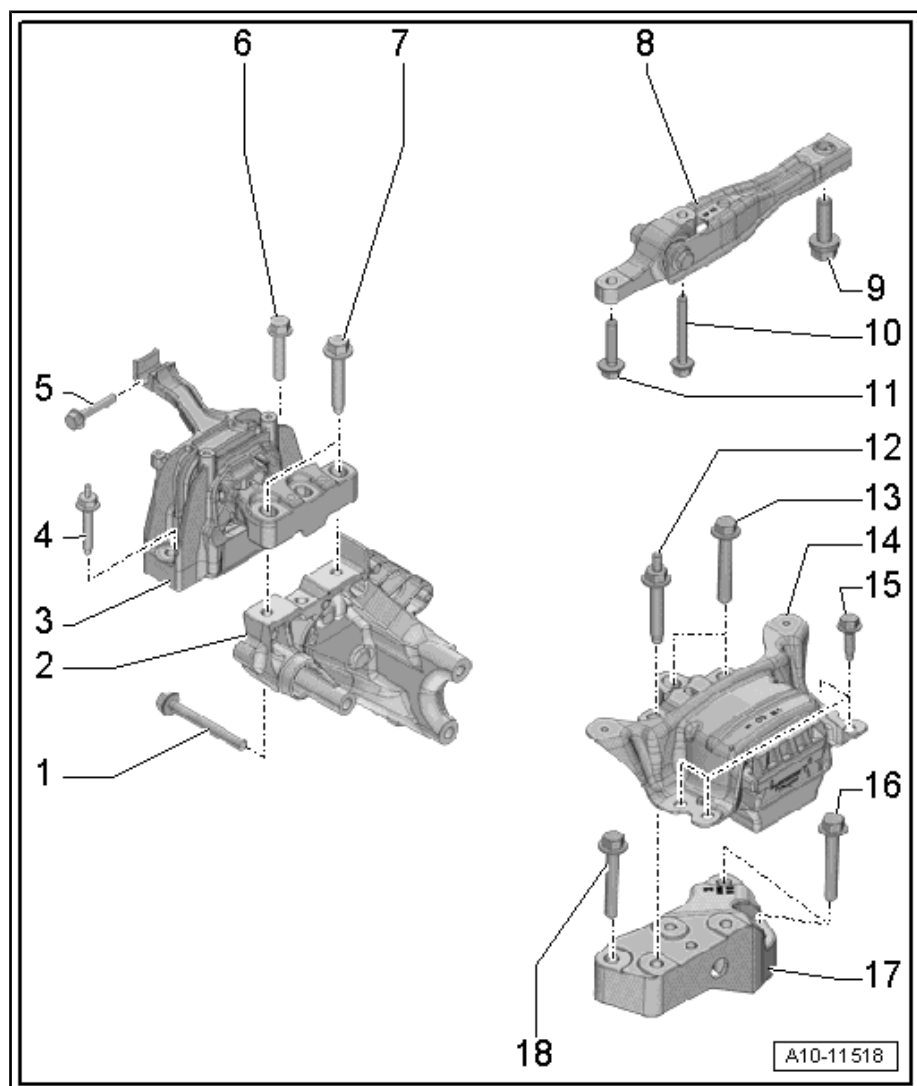

### 11 - Bolts

- Renew
- Tightening torque and sequence ⇒ [page 51](#) .

### 12 - Bolt.

- Renew
- 60 Nm + turn +90° further

### 13 - Bolt.

- Renew
- 60 Nm + turn +90° further

### 14 - Gearbox mounting

- With support arm
- Removing and fitting ⇒ [page 46](#)

### 15 - Bolt.

- Renew
- 50 Nm + turn +90° further

### 16 - Bolt.

- Tightening torque ⇒ Rep. gr. 34 ; Assembly mountings; Exploded view - assembly mountings

### 17 - Gearbox support

- For vehicles with manual gearbox

### 18 - Bolt.

- Tightening torque ⇒ Rep. gr. 34 ; Assembly mountings; Exploded view - assembly mountings

## 2.2 Removing and installing engine mountings

### Special tools and workshop equipment required

- ◆ Torque wrench - V.A.G 1331-



- ◆ Torque wrench - V.A.G 1332-



## Removal

- Remove engine cover. ⇒ [page 56](#)
- Unplug the electrical connector -1-.
- Remove the bracket -2- with fuel hoses.
- Using a screwdriver, release fasteners -arrow- and move coolant expansion tank to one side.

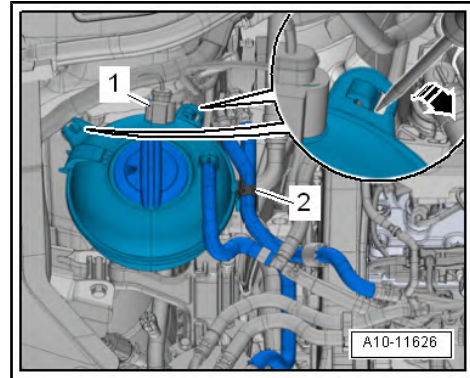

- Move clear bracket -3- with fuel hoses.
- Unscrew nut -2- and bolts -1-.
- Move fuel filter -4- clear to one side.
- Support engine and gearbox in installation position ⇒ [page 51](#) .
- Take up weight of engine/gearbox assembly slightly with spindle; do not lift.

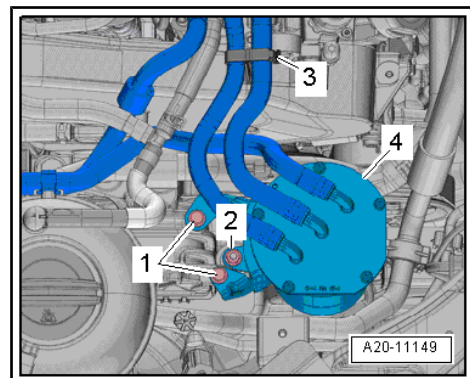

- Remove bolts -arrows- and detach engine mounting -1-.

## Installation

Installation is carried out in the reverse order; note the following:

- Check adjustment of assembly mountings (engine/gearbox mountings) ⇒ [page 55](#) .

## Specified torques

- ◆ ⇒ [“2.1 Exploded view - assembly mountings”, page 44](#)
- ◆ Assembly overview - fuel filter ⇒ Rep. gr. 20 ; Fuel filter; Assembly overview - fuel filter .
- ◆ Assembly overview - windscreen wiper system ⇒ Electrical system; Rep. gr. 92 ; Windscreen wiper system; Assembly overview - windscreen wiper system .

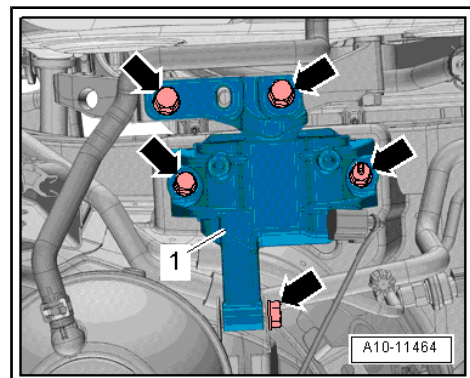

## 2.3 Removing and installing gearbox mounting

Special tools and workshop equipment required

- ◆ Torque wrench - V.A.G 1331-

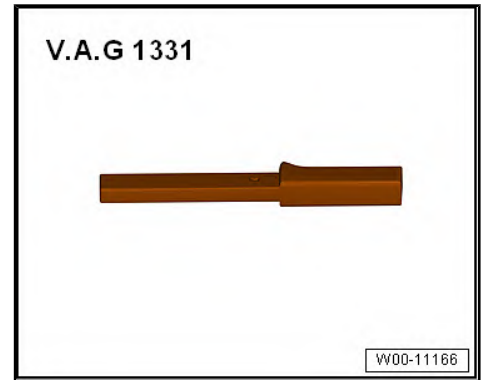

- ◆ Torque wrench - V.A.G 1332-



### Removal

- For reasons of space, remove the air filter housing together with the intake hose ⇒ [page 321](#) .
- Remove battery tray -1- ⇒ Electrical system; Rep. gr. 27 ; Battery; battery tray: removing and installing .

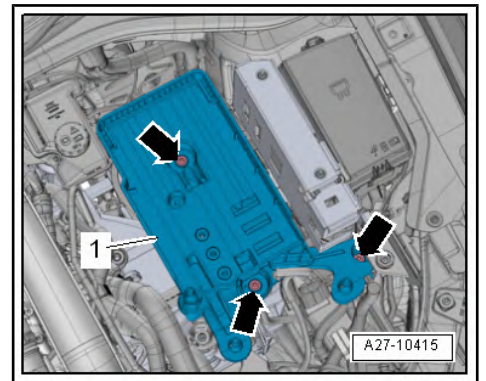

- Remove the engine control unit - J623- from the bracket ⇒ [page 350](#) .

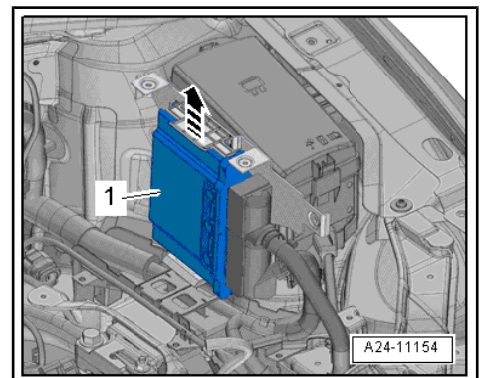

- Remove nuts -arrows- and detach bracket -1-.



**Note**

*Different types of brackets are fitted depending on version.*

- Open cable duct -2- upwards -in the direction of arrow-, release fastening clip -1- for the lines.
- Release the requisite plug connections and clips.

- Remove line guide -1- from its clips, slide upwards -in direction of arrow- and secure on one side.

- Depending on version, unscrew and remove nut -Arrow- and expose the earth wire.
- Support engine and gearbox in installation position  
⇒ [page 51](#) .
- Take up weight of engine/gearbox assembly slightly with spindle; do not lift.

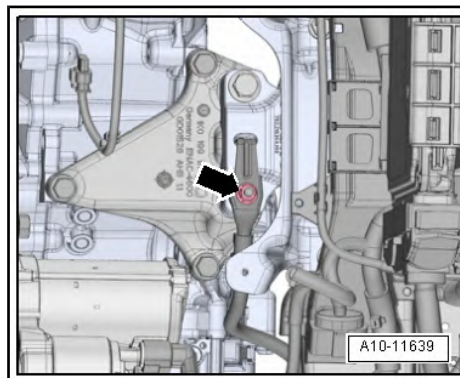
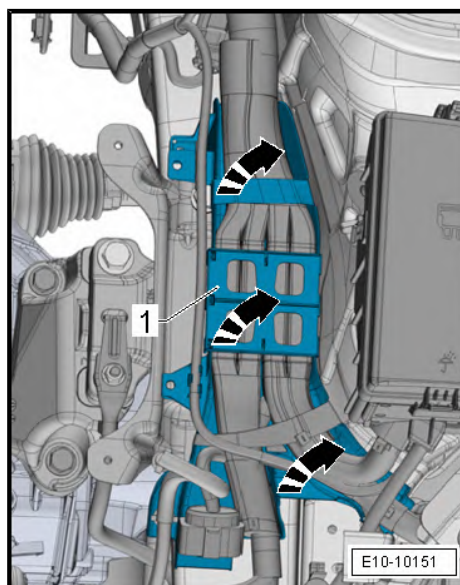
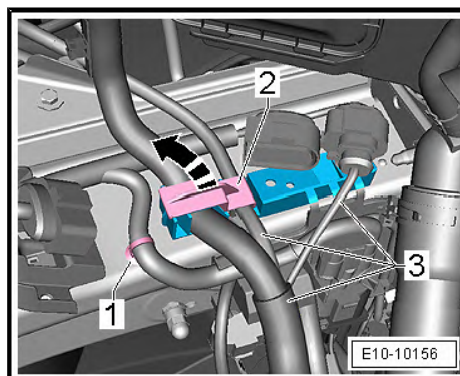
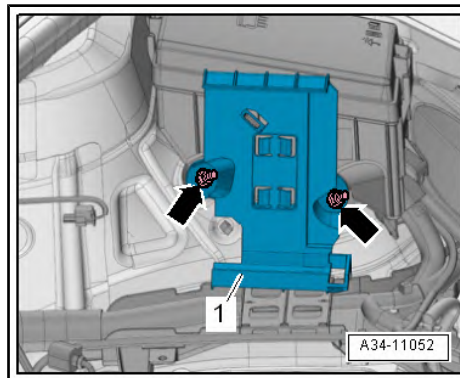

- Unscrew the bolts -arrows- and remove the gearbox mounting -1-.

### Installation

Installation is carried out in the reverse order; note the following:

#### Note

*Renew bolts that are tightened with turning further angle after each removal.*

- Tighten bolts of gearbox mounting to longitudinal member.

#### Note

- ◆ *Risk of damage to threads by starting bolts at an angle.*
- ◆ *Renew bolts that are tightened with turning further angle after each removal.*
- Lift gearbox with the spindle of the gearbox support until the gearbox support makes contact with the support arm of the gearbox mounting.
- Assembly mountings: check setting ⇒ [page 55](#) .
- Remove the gearbox support - 10 - 222 A- from the engine.

### Specified torques

- ◆ ⇒ ["2.1 Exploded view - assembly mountings", page 44](#)
- ◆ ⇒ ["1.1 Exploded view - turbocharger", page 252](#)
- ◆ Battery; Exploded view - battery ⇒ Electrical system; Rep. gr. 27 ; Battery; Exploded view - battery
- ◆ Assembly overview - windscreen wiper system ⇒ Electrical system; Rep. gr. 92 ; Windscreen wiper system; Assembly overview - windscreen wiper system .

## 2.4 Removing and installing pendulum support

### Special tools and workshop equipment required

- ◆ Torque wrench - V.A.G 1331-

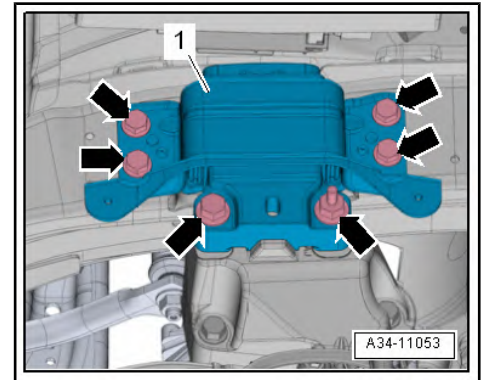

- ◆ Torque wrench - V.A.G 1332-



### Removal

- Remove noise insulation ⇒ General body repairs, exterior; Rep. gr. 66 ; Noise insulation; Removing and installing noise insulation .
- Remove bolts -1, 2, 3- and detach pendulum support.

### Note

*A vehicle with manual gearbox 02Q is shown in the illustration as an example.*

### Installation

Installation is carried out in the reverse order; note the following:

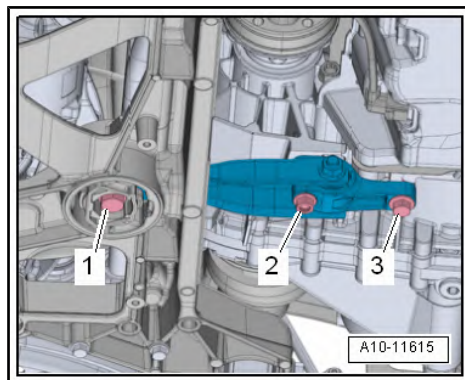

### Note

- ◆ *Bolt holes for pendulum support are fitted with thread inserts (e.g. "HeliCoil").*
- ◆ *ID: bead shoulder threaded on the first rotation -Arrow-.*

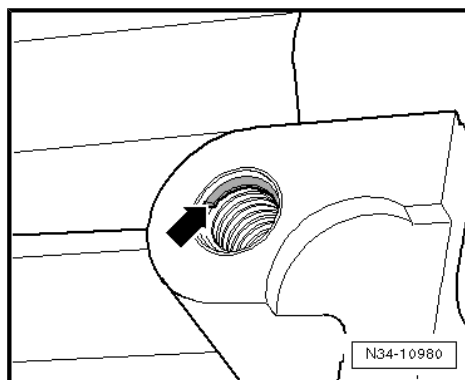

## Bolted connection for pendulum support



*Renew bolts that are tightened with turning further angle after each removal.*

- Tighten bolts in stages in the sequence shown:

### Specified torques

stage	Bolts	Tightening torque/angle specification
1st	-2, 3-	50 Nm
2nd	-1-	130 Nm
3	-1 ...°3-	turn 90° further

- ◆ Install noise insulation ⇒ General body repairs, exterior; Rep. gr. 66 ; Noise insulation; Assembly overview - Noise insulation .

## 2.5 Supporting engine in installation position

### Special tools and workshop equipment required

- ◆ Gearbox support - 10 - 222 A-

- ◆ Adapter - 10-222A/8-

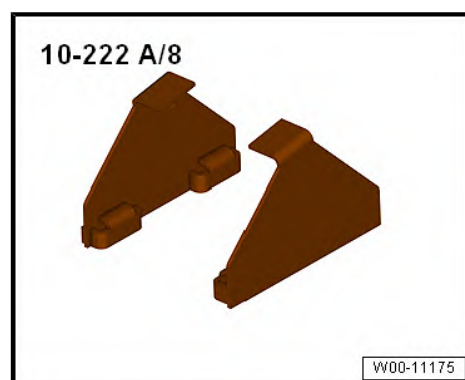
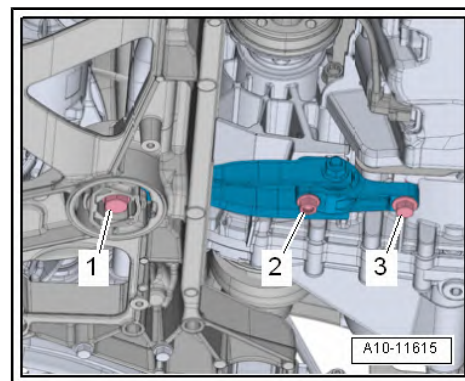

◆ Spindle - 10 - 222 A /10-

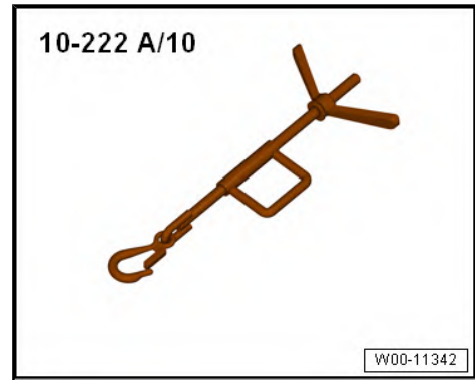

◆ Shackle - 10 - 222 A /12-



◆ Adapter - 10 222A/3-

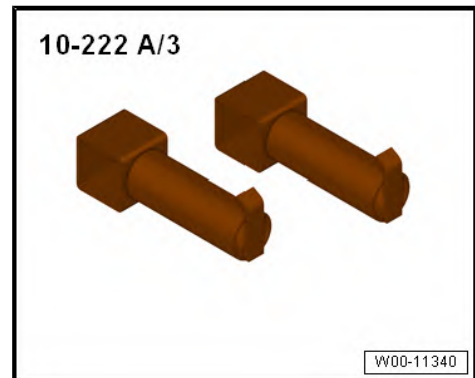

◆ Gauge - T40045-

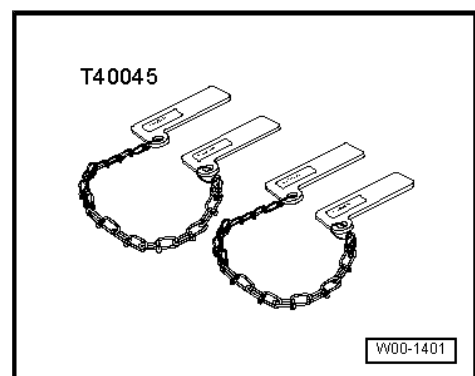

To prevent damage to edges of wings, cover lower areas of both adapters - 10 - 222 A /8- with woven adhesive tape -arrow- → Electronic Parts Catalogue (ETKA) .

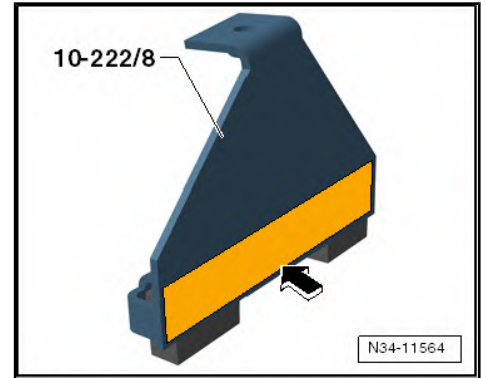

### Work sequence

- Remove engine cover. ⇒ [page 56](#)
- Release hose clamps -3- and -4-; remove the air hose.
- Lay bare the vacuum hoses at the air pipe -arrows-.



### Note

*Disregard -item 1, 2-.*

- Insert and position the gauge - T40045- -2- as shown in the illustration on the front longitudinal members left and right, observe the dimension -a- in doing so.
- Attach the adapter - 10 - 222 A /8- -1- on left and right onto longitudinal members as shown in illustration.

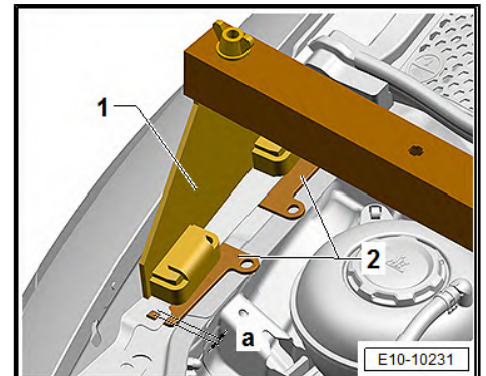
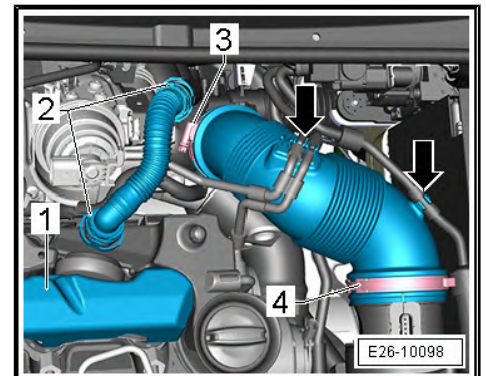

- Slide the adapters - 10 - 222 A /3- -2- onto the engine interception device - 10 - 222 A- -1-.
- Screw in the adapter - 10 - 222 A /8- -3- into the engine interception device - 10-222 A- -1-.
- Insert the engine interception device - 10 - 222 A- -1- and the adapter - 10 - 222 A /8- -3- on left and right onto longitudinal members as shown.

Observe the position and setting of the gauge - T40045- -4- ⇒ [page 53](#) .

- Fit the spindles - 10 - 222 A /10- -5- on the adapters - 10 - 222 A /3- -2-.
- Fit the shackle - 10 - 222 A /12- -6- in the right lifting eye of the engine.
- Hook the karabiners of the spindles - 10 - 222 A /10- -5- onto the shackle - 10 - 222 A /12- -6-.
- Tighten spindle to take up weight of engine/gearbox assembly; do not lift.

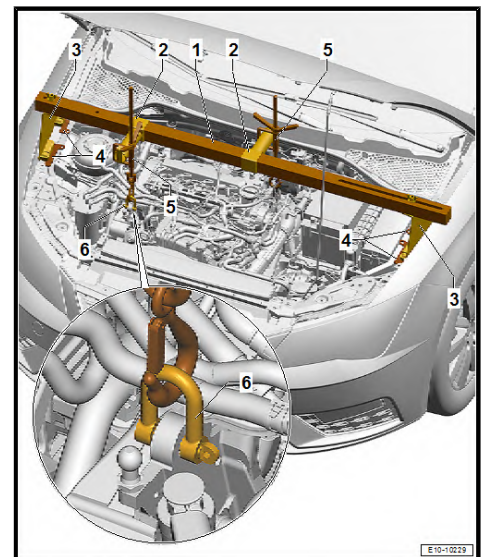

## 2.6 Adjusting assembly mounting

### Operation process

- Remove engine cover. ⇒ [page 56](#)
  - Remove battery tray -1- ⇒ Electrical system; Rep. gr. 27 ; Battery; battery tray: removing and installing .
  - Support engine and gearbox in installation position ⇒ [page 51](#) .
  - Take up weight of engine/gearbox assembly slightly with spindle; do not lift.
  - Unscrew the bolts -arrows- on the engine mounting one at a time and replace them (provided not already done during installation of the engine).
  - First screw bolts in loosely.
- 
- Remove bolts -arrows- for gearbox mounting -1- one by one and renew (if they were not renewed when installing engine).
  - First screw bolts in loosely.

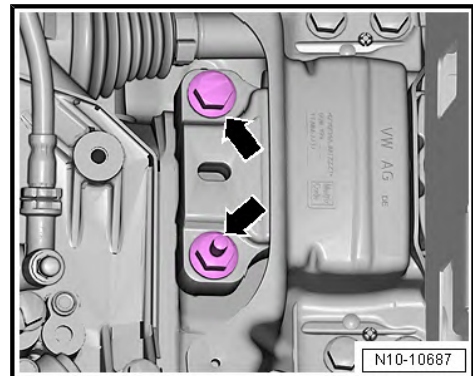
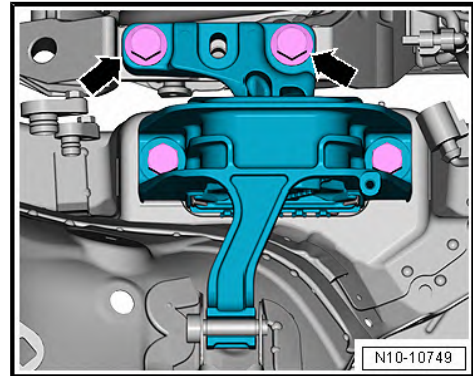

### Adjustment dimensions of the assembly mounting

- Using assembly lever, adjust engine/gearbox assembly so that specifications listed below are attained:
- There must be a distance of -a- = 10 mm between engine support -2- and engine mounting -1-.
- Side surface of the engine support casting should be located parallel to support arm of engine mounting.
- Distance -b- = distance -b-.



#### Note

*For example, distance -a- = 10 mm can be checked with a metal rod of suitable size.*

- Tighten bolts of engine mounting.

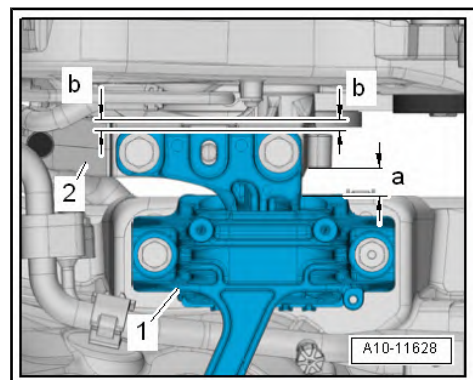

- Ensure that the edges of the support arm (on the gearbox assembly mounting) -1- and gearbox mounting -2- are parallel.
- Dimension -x- = dimension -x-.
- Tighten bolts for gearbox mounting.

Installation is in the reverse sequence of removal.

### Specified torques

- ◆ ⇒ ["2.1 Exploded view - assembly mountings", page 44](#)
- ◆ Assembly overview - battery ⇒ Electrical system; Rep. gr. 27 ; Battery; Assembly overview - battery .
- ◆ Assembly overview - windscreen wiper system ⇒ Electrical system; Rep. gr. 92 ; Windscreen wiper system; Assembly overview - windscreen wiper system .

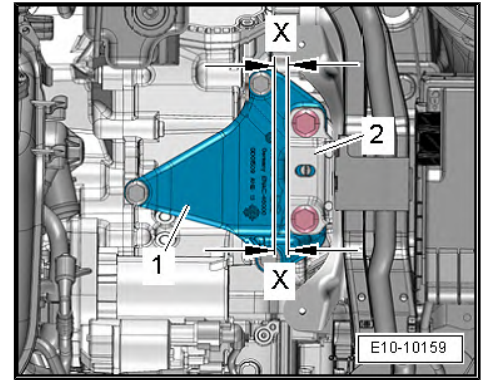

## 2.7 Checking adjustment of assembly mountings

### Operation process

The following dimensions must be reached:

- There must be a distance of -a- = 10 mm between engine support -2- and engine mounting -1-.
- Side surface of engine support casting should be located parallel to support arm of engine mounting.



*For example, distance -a- = 10 mm can be checked with a metal rod of suitable size.*

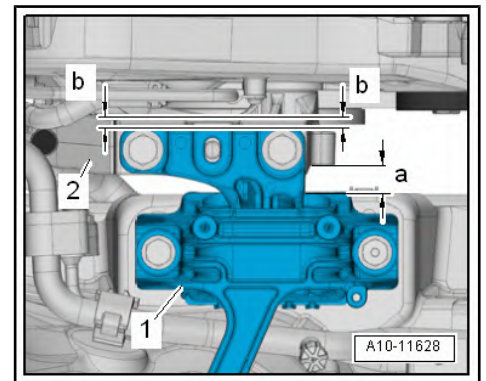

- If the gap is too narrow or too wide when measured you must adjust the assembly mounting ⇒ [page 54](#) .

### 3 Engine cover

⇒ "3.1 Removing and installing engine cover panel", page 56

#### 3.1 Removing and installing engine cover panel

##### Removal



##### Caution

*When removing and installing the engine cover panel care must be taken to prevent a possible collision with the fuel return line. In the worst possible case scenario the fuel return connectors on the injectors could break. The consequences would be leaks in the fuel system.*

- Carefully pull engine cover panel off retaining pins one after the other -arrows-. Do not pull off engine cover panel abruptly or just on one side.

##### Installation

- To prevent damage, do not strike engine cover with the fist or a tool.
- Position engine cover panel, paying attention to oil filler neck and dipstick.
- Press the engine cover panel into the rubber grommets on the left-hand side first and subsequently into those on the right-hand side.

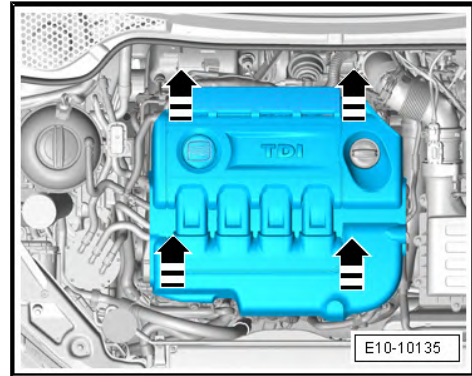

## 13 – Crankshaft group

### 1 Cylinder block (pulley end)

⇒ “1.1 Exploded view - cylinder block (pulley end)”, page 57

⇒ “1.2 Assembly overview - Sealing flange, belt pulley end.”, page 59

⇒ “1.3 Removing and installing poly V-belt”, page 59

⇒ “1.4 Removing and installing tensioner for poly V-belt”, page 61

⇒ “1.5 Removing and installing vibration damper”, page 61

⇒ “1.6 Removing and installing ancillary bracket”, page 61

⇒ “1.7 Removing and installing engine support”, page 63

⇒ “1.8 Removing and installing sealing flange - pulley end”, page 64

#### 1.1 Exploded view - cylinder block (pulley end)

##### 1 - Poly-V belt

- Check for wear
- Mark direction of rotation with chalk or felt pen before removing
- Do not kink.
- Routing of poly V-belt  
⇒ page 60
- Removing and fitting  
⇒ page 59
- When installing, make sure it is properly seated on the pulleys.

##### 2 - Bolt.

- Renew
- Use only genuine bolts  
⇒ Electronic parts catalogue
- 10 Nm + turn +90° further

##### 3 - Vibration damper

- With poly V-belt pulley
- Installation position: hole in vibration damper must align over protrusion on crankshaft toothed belt pulley.
- Removing and fitting  
⇒ page 61

##### 4 - Tensioning device for V-ribbed belt

- Removing and fitting  
⇒ page 61

##### 5 - Bolt.

- Renew

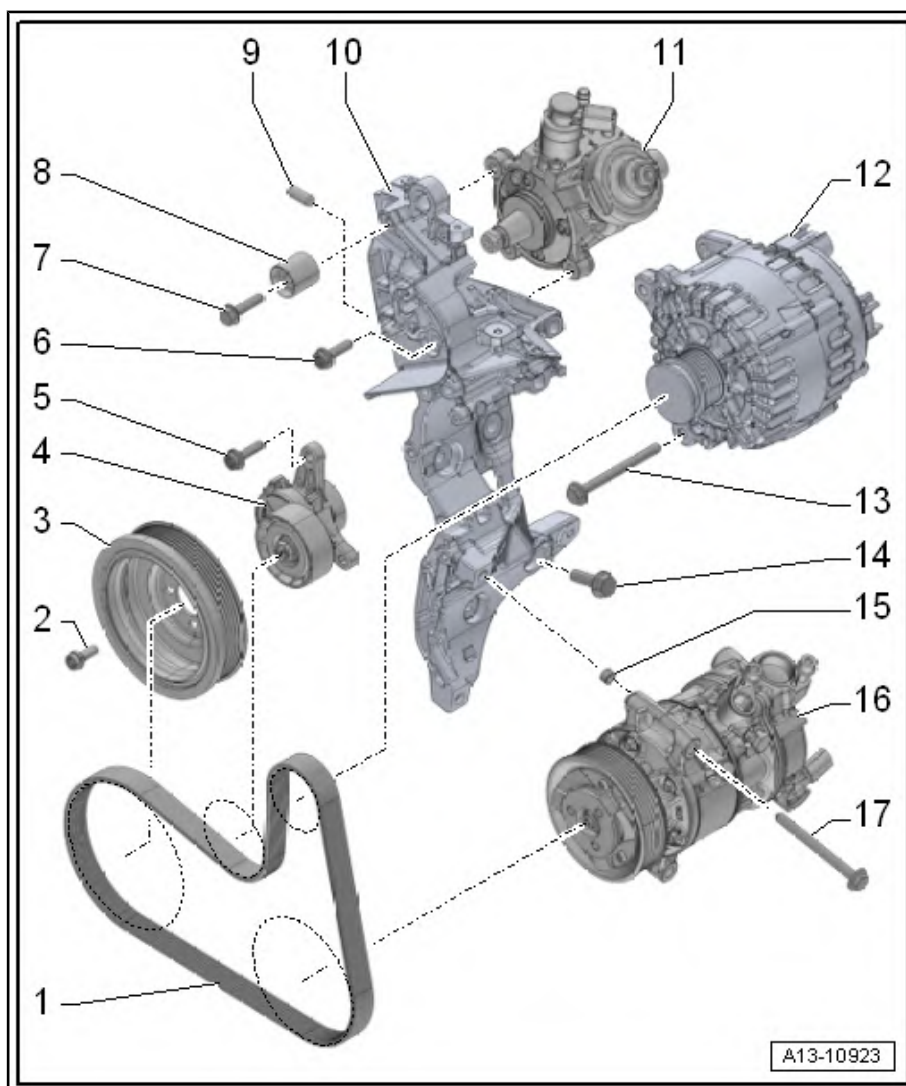

- 20 Nm + turn +90° further
- 6 - Bolt.**
  - Tightening torque ⇒ [page 356](#)
- 7 - Bolt.**
  - Tightening torque ⇒ [Item 12 \(page 115\)](#)
- 8 - Damper wheel**
- 9 - Dowel sleeve**
  - Check for correct seating in ancillary bracket.
- 10 - Bracket for ancillary mechanical units**
  - Removing and fitting ⇒ [page 61](#)
- 11 - High-pressure pump**
  - Assembly overview ⇒ [page 356](#)
- 12 - Alternator:**
  - Exploded view ⇒ Electrical system; Rep. gr. 27 ; Alternator; Alternator: Exploded view
- 13 - Bolt.**
  - Tightening torque ⇒ Electrical system; Rep. gr. 27 ; Alternator; Alternator: Exploded view
- 14 - Bolt.**
  - Different lengths ⇒ [page 58](#)
  - Tightening torque and sequence ⇒ [page 58](#) .
- 15 - Dowel sleeve**
  - Ensure correct seating in air conditioner compressor
- 16 - Air conditioning compressor**
  - Exploded view ⇒ Rep. gr. 87 ; Air conditioner compressor; Exploded view - air conditioner compressor drive unit
- 17 - Bolt.**
  - Tightening torque ⇒ Rep. gr. 87 ; Air conditioner compressor; Exploded view - air conditioner compressor drive unit

**Bracket for ancillaries - tightening torque and tightening sequence**



**Note**

*Renew the bolts tightened with specified tightening angle.*

- Fit bolts in the following sequence:
- ◆ Bolts -1, 2, 3, 6- M10x35
- ◆ Bolt -4- M10x115
- ◆ Bolt -5- M10x175
- Tighten the bolts in steps in the indicated sequence:

stage	Bolts	Tightening torque/angle specification
1st	-1 ... 6-	Screw in by hand until they make contact
2nd	-1 ... 6-	40 Nm
3.	-4- and -5-	turn 180° further
4.	-1, 2, 3, 6-	turn 45° further

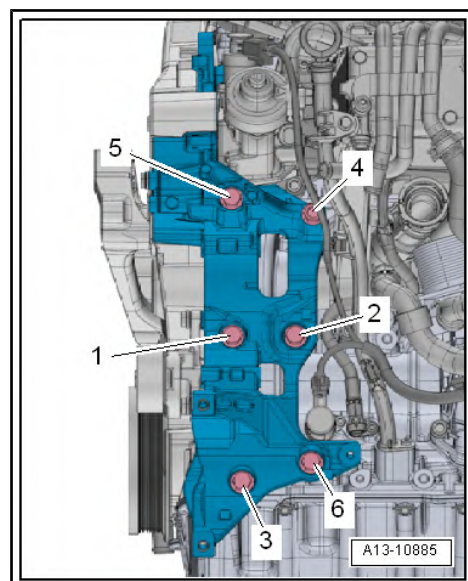

## 1.2 Assembly overview - Sealing flange, belt pulley end.

### 1 - Sealing flange (pulley end)

- With crankshaft oil seal
- Always renew after removing
- Removing and fitting ⇒ [page 64](#)

### 2 - Bolt.

- Tightening torque and sequence ⇒ [page 59](#) .

### 3 - Crankshaft pulley

- Contact surface between sprocket and crankshaft must be free of oil
- Fitting possible in one position only.

### 4 - Bolt.

- Tightening torque ⇒ [Item 1 \(page 115\)](#)

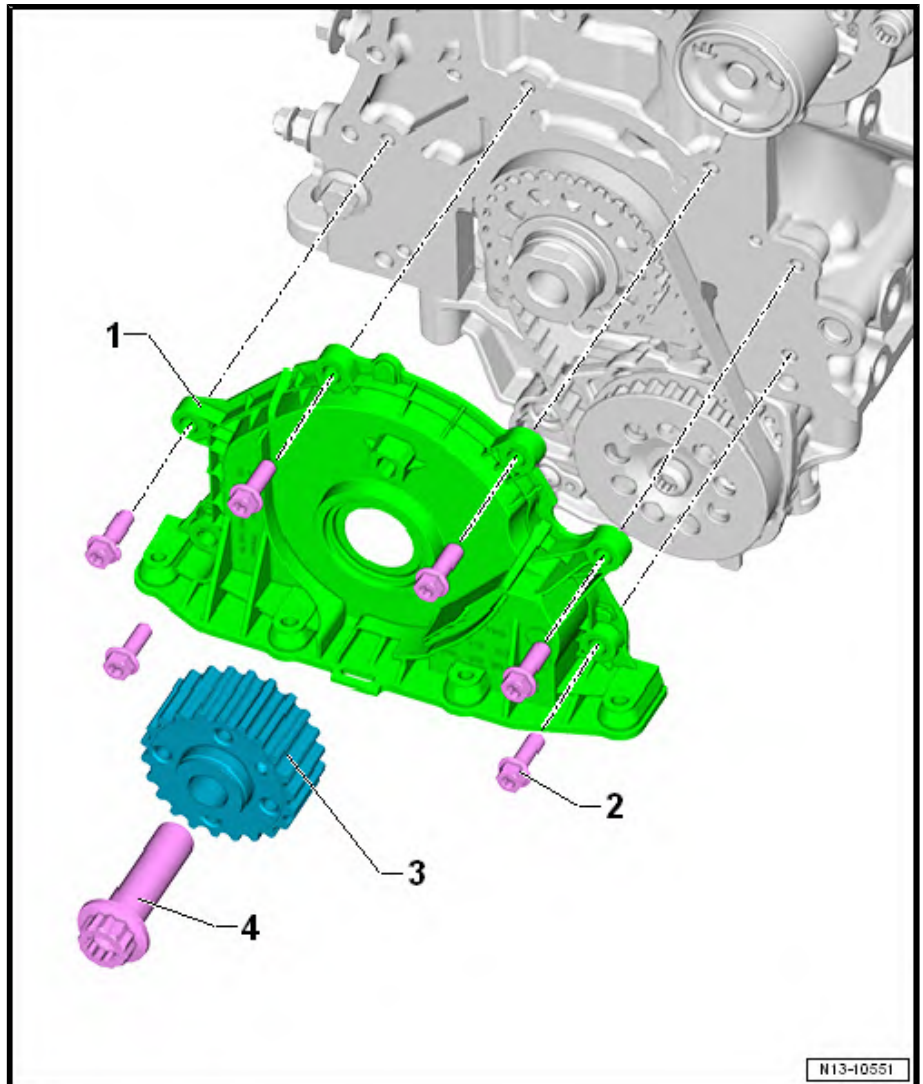

### Sealing flange (pulley end) - tightening torque and sequence

– Tighten the bolts in steps in the indicated sequence:

stage	Bolts	Tightening torque
1st	-1 ... 10-	Screw in by hand until they make contact
2nd	-1 ... 6-	Tighten in stages and in diagonal sequence; final torque 13 Nm
3.	-7 ... 10-	13 Nm

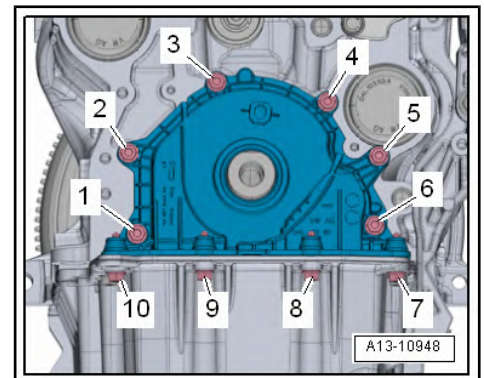

## 1.3 Removing and installing poly V-belt

Special tools and workshop equipment required

◆ Locking pin - T10060 A-

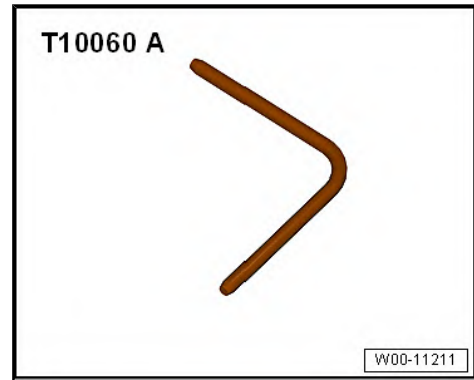

**Removal**

- Remove noise insulation ⇒ General body repairs, exterior; Rep. gr. 66 ; Noise insulation; Removing and installing noise insulation .
- Before removing the Poly-V belt, mark the direction of rotation with chalk or felt-tipped pen for re-installation.
- To slacken poly V-belt turn tensioner in anti-clockwise direction -arrow- using ring spanner.
- Secure tensioner with locking pin - T10060 A- .
- Remove the V-ribbed belt.

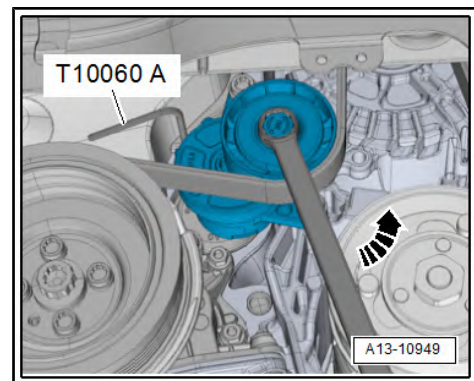

**Installation**

Installation is carried out in the reverse order; note the following:

- Fit poly V-belt on poly V-belt pulley:
  - 1 - Vibration damper
  - 2 - Tensioning roller
  - 3 - Alternator:
  - 4 - Air conditioning compressor

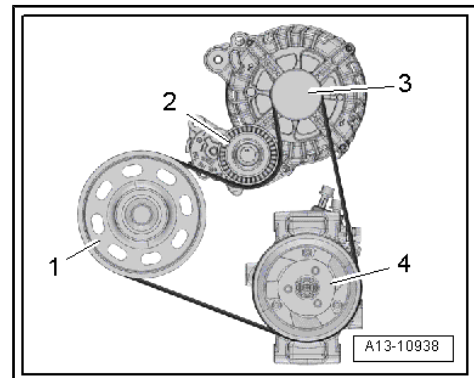

- Hold tensioner with ring spanner and remove locking pin - T10060 A- .
- Release tensioner.
- Check that Poly-V belt is properly positioned.
- Start engine and check that belt runs properly.

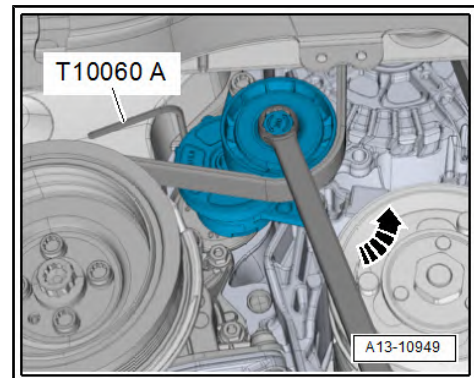

**Specified torques**

- ◆ Install noise insulation ⇒ General body repairs, exterior; Rep. gr. 66 ; Noise insulation; Assembly overview - Noise insulation .

## 1.4 Removing and installing tensioner for poly V-belt

### Removal

- Remove the poly V-belt ⇒ [page 59](#) .
- Unscrew bolts -arrows-, Detach tensioning device from poly V-belt.

### Installation

Installation is carried out in the reverse order; note the following:



#### Note

*Renew the bolts tightened with specified tightening angle.*

- Fit poly V-belt ⇒ [page 59](#) .

### Specified torques

- ◆ ⇒ [“1.1 Exploded view - cylinder block \(pulley end\)”, page 57](#)

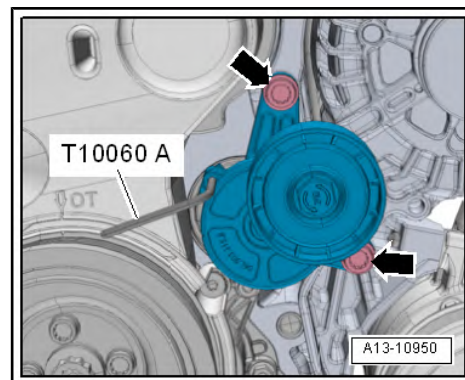

## 1.5 Removing and installing vibration damper

### Removal

- Remove the poly V-belt ⇒ [page 59](#) .
- Counterhold by applying ring spanner to bolt for crankshaft sprocket and slacken bolts for vibration damper.
- Remove bolts and take off vibration damper.

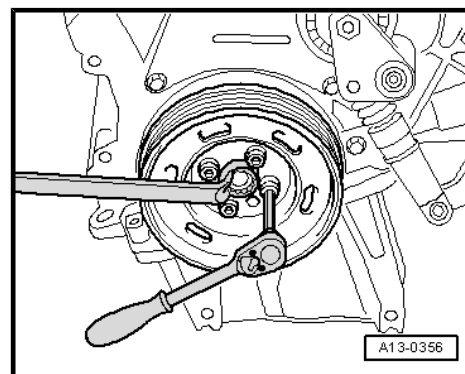

### Installation

Installation is carried out in the reverse order; note the following:



#### Note

*Renew the bolts tightened with specified tightening angle.*

- Installation position: hole -arrow- in vibration damper must be positioned over raised section of crankshaft sprocket.
- Fit poly V-belt ⇒ [page 59](#) .

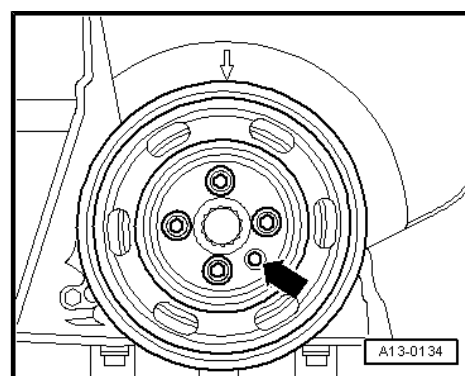

### Specified torques

- ◆ ⇒ [“1.1 Exploded view - cylinder block \(pulley end\)”, page 57](#)

## 1.6 Removing and installing ancillary bracket

### Removal

- Remove alternator ⇒ Electrical system; Rep. gr. 27 ; Alternator; Removing and installing alternator .

- Remove high-pressure pump ⇒ [page 357](#) .
- Remove nut -2- and bolt -1- and press coolant pipe (front right) slightly towards front.

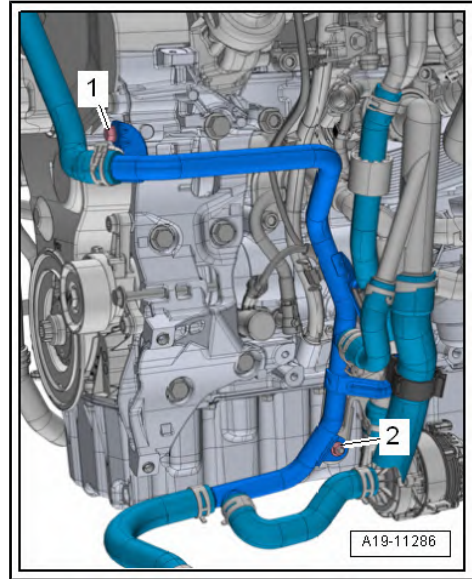

- Unclip bracket -1- with fuel hoses.
- Remove bolts -arrows-.



**Note**

*Disregard -item 2, 3-.*

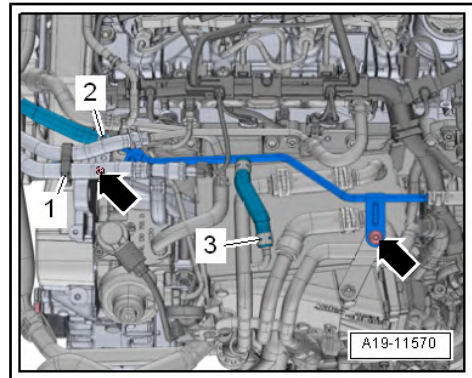

- Remove bolt -arrow- and detach damper wheel.

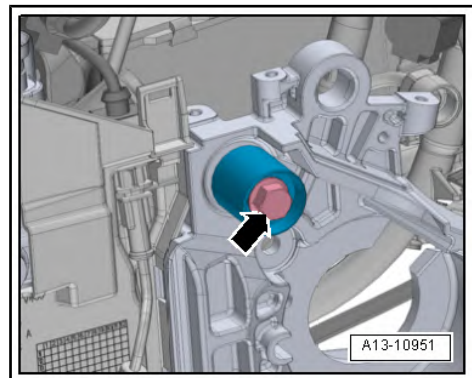

- Loosen bolts in the sequence -6 ... 1-.
- Remove bolts and detach bracket for ancillaries.

### Installation

Installation is carried out in the reverse order; note the following:

#### Note

*Renew bolts that are tightened with turning further angle after each removal.*

- Check that a dowel sleeve is fitted between bracket for ancillaries and cylinder block.

### Specified torques

- ◆ ⇒ [Fig. “Bracket for ancillaries - tightening torque and tightening sequence”](#), page 58
- ◆ ⇒ [“2.2 Exploded view - toothed belt”](#), page 115
- ◆ ⇒ [“3.1 Exploded view - coolant pipes”](#), page 208
- ◆ ⇒ [“8.1 Exploded view - high-pressure pump”](#), page 356
- ◆ Assembly overview - alternator ⇒ Electrical system; Rep. gr. 27 ; Alternator; Assembly overview - alternator .

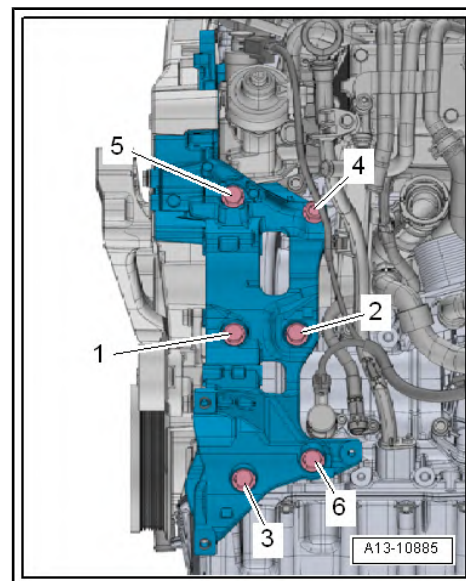

## 1.7 Removing and installing engine support

### Removal

- Remove engine mounting ⇒ [page 45](#) .
- Remove toothed belt cover (top) ⇒ [page 116](#) .
- Using spindle - 10 - 222 A /11- raise or lower engine until the respective bolt of the engine support is accessible.

#### Note

*To remove bolt -2- the engine support must first be removed.*

- Unscrew bolts -1, 2 and 3- and detach engine support.

### Installation

Installation is carried out in the reverse order; note the following:

- Fit bolt -2- into hole in engine support before inserting engine support.

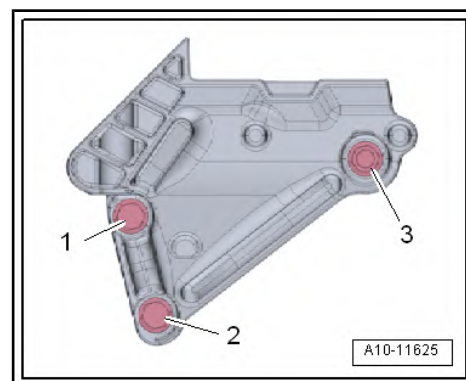

- Attach engine supports and -1, 2, 3- first tighten hand-tight, and then tighten with the prescribed torque and sequence ⇒ [page 64](#)
- Install toothed belt cover (top) ⇒ [page 116](#) .
- Install engine mountings ⇒ [page 45](#) .

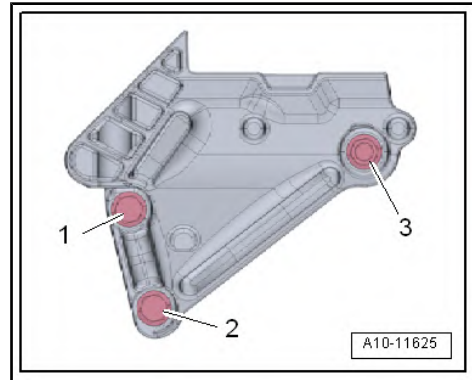

### Engine support - Tightening torque and sequence



#### Note

*Renew bolts that are tightened with turning further angle after each removal.*

- Tighten the bolts in steps in the indicated sequence:

#### Specified torques

stage	Bolts	Tightening torque / tightening angle
1st	-1 ... °3-	7 Nm
2nd	-1 ... °3-	40 Nm
3.	-1 ... °3-	Turn 180° further

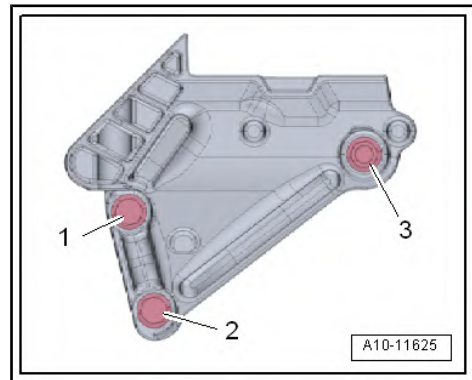

## 1.8 Removing and installing sealing flange - pulley end

### Special tools and workshop equipment required

- ◆ retention tool - 3415-

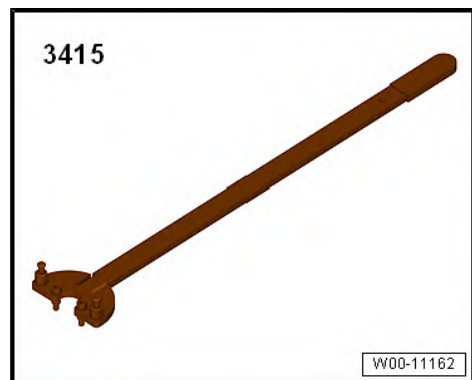

- ◆ Installation tool - T10053-

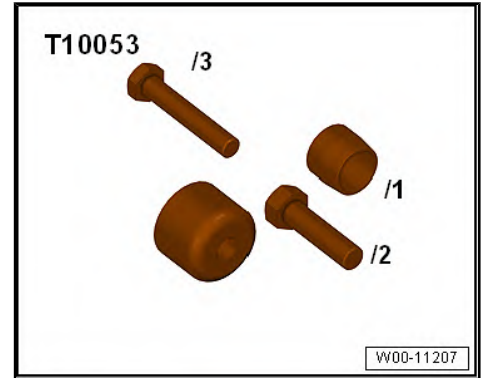

- ◆ Hand drill with plastic brush
- ◆ Protective glasses
- ◆ Sealant → Electronic parts catalogue

### Removal

- Remove front right-hand spoiler wheel housing shell ⇒ General body repairs, exterior; Rep. gr. 66 ; Wheel housing shell; Assembly overview - Front wheel housing shell .
- Remove the notched belt ⇒ [page 120](#) .
- Loosen bolt for crankshaft sprocket using counterhold tool - 3415- .
- Remove bolt and detach crankshaft sprocket.
- Remove the oil sump ⇒ [page 161](#) .
- Unscrew remaining bolts and carefully release sealing flange from bonded joint.
- Remove sealant residue on cylinder block and oil pan using commercially available, chemical sealant remover.
- The sealing surfaces must be free of oil and grease.

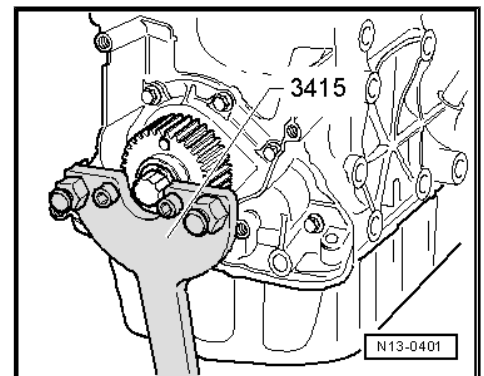

### Installation

Installation is carried out in the reverse order; note the following:

- Fit guide sleeve -T10053/1- onto crankshaft journal.

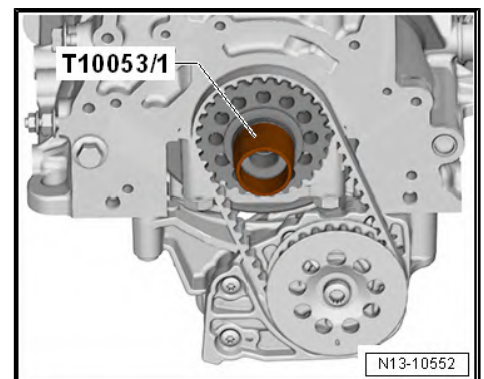

 **Note**

Observe use-by date of sealant.



**Caution**

**Danger of blocking lubrication system with excess sealant.**

◆ **Thickness of sealant bead: 2...3 mm.**

- Apply bead of sealant -arrow- onto clean sealing surface of sealing flange as shown in illustration.
- Apply sealant bead of about 2 ... 3 mm in thickness.
- Install the sealing flange within 5 minutes after the sealant has been applied.
- Slide new sealing flange over guide sleeve.
- Dowel pins should then engage in bores on cylinder block.
- Take off guide sleeve.
- Screw in sealing flange bolts as far as stop by hand.
- Tighten the securing bolts of the sealing flange working diagonally and in accordance with the correct tightening torque and tightening sequence ⇒ [page 59](#) .
- Install sump ⇒ [page 161](#) .
- Install notched belt (adjusting valve timing) ⇒ [page 125](#) .

**Specified torques**

- ◆ Bolt for crankshaft pulley ⇒ [Item 1 \(page 115\)](#)
- ◆ Assembly overview - front wheel housing liner ⇒ General body repairs, exterior; Rep. gr. 66 ; Wheel housing liner; Assembly overview - front wheel housing liner .

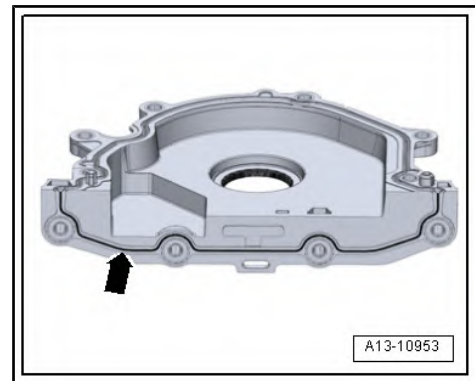
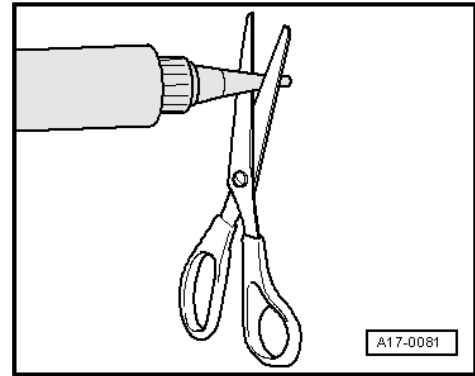

## 2 Cylinder block, gearbox end

⇒ [“2.1 Exploded view - cylinder block, gearbox end”, page 67](#)

⇒ [“2.2 Removing and installing flywheel”, page 68](#)

⇒ [“2.3 Removing and installing sealing flange \(gearbox end\)”, page 69](#)

### 2.1 Exploded view - cylinder block, gearbox end

#### 1 - Bolt.

- Renew
- 60 Nm + turn +90° further

#### 2 - Flywheel

- Removing and fitting  
⇒ [page 68](#)
- Fitting can only be completed in one position only:

#### 3 - Sender wheel

- For engine speed sender - G28- .
- Removing and fitting  
⇒ [“2.3 Removing and installing sealing flange \(gearbox end\)”, page 69](#)

#### 4 - Engine speed sensor - G28-

- Assembly overview  
⇒ [page 443](#)

#### 5 - Bolt.

- Tightening torque  
⇒ [page 443](#)

#### 6 - Dowel pin

- 2 off

#### 7 - Intermediate plate

- Do not damage or bend when assembling
- Installation ⇒ [page 68](#)

#### 8 - Sealing flange (gearbox end)

- With seal
- Renew ⇒ [page 69](#)

#### 9 - Bolt.

- Tightening torque and sequence ⇒ [page 68](#) .

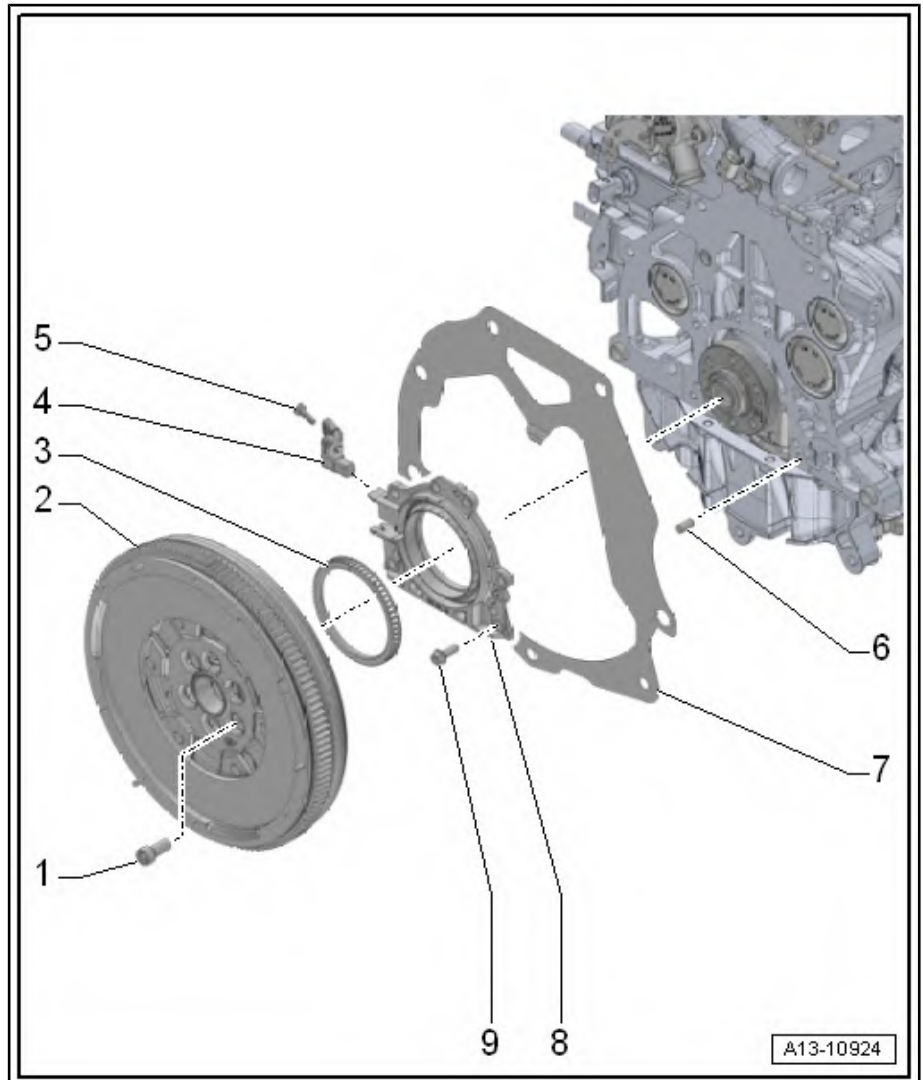

**Install intermediate plate.**

- Engage intermediate plate on sealing flange -top arrow- and push onto dowel sleeves -bottom arrows-.

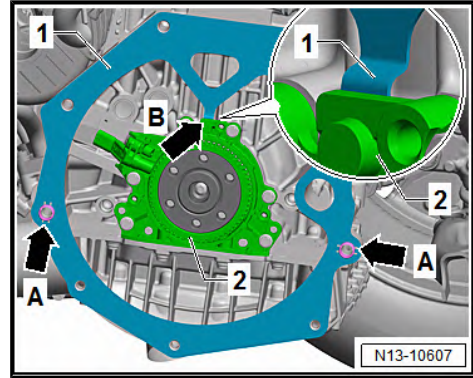

**Sealing flange on gearbox side - Prescribed torque and tightening sequence**

- Tighten the bolts in steps in the indicated sequence:

stage	Bolts	Tightening torque
1st	-1 ... 6-	Screw in by hand until they make contact
2nd	-1 ... 6-	Tighten in stages and in diagonal sequence; final torque 13 Nm

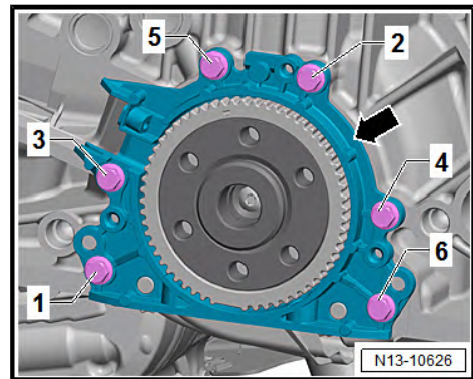

**2.2 Removing and installing flywheel**

**Special tools and workshop equipment required**

- ◆ retention tool - 3067-



**Removal**

- Gearbox is removed.

**Caution**

*Risk of serious damage to flywheel.*

- ◆ Remove bolts -B- using normal hand tools (do not use pneumatic wrench or impact driver, etc.).
- ◆ When removing the bolts, make sure that the bolt heads do not come into contact with the flywheel.
- ◆ Rotate the flywheel -A- so that bolts -B- are aligned with the holes -arrows-.

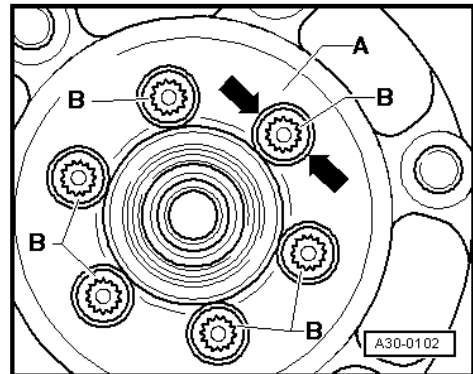

- Insert counterhold tool - 3067- in hole of the cylinder block -item B-, and slacken bolts for the flywheel.
- Remove bolts and take off flywheel.

### Installation

Installation is carried out in the reverse order; note the following:



*Renew the bolts tightened with specified tightening angle.*

- Insert the counterhold - 3067- into the borehole in the engine block -item A-.

### Specified torques

- ◆ => ["2.1 Exploded view - cylinder block, gearbox end", page 67](#)

## 2.3 Removing and installing sealing flange (gearbox end)

Special tools and workshop equipment required

- ◆ 24 mm tool insert - V.A.G 1332/11-

- ◆ Installation tool - T10134-

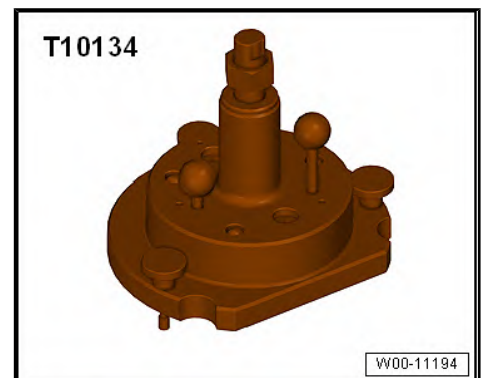
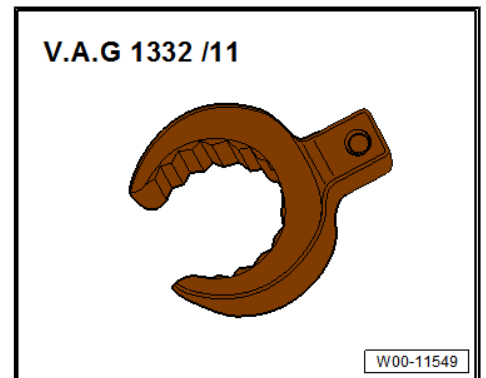
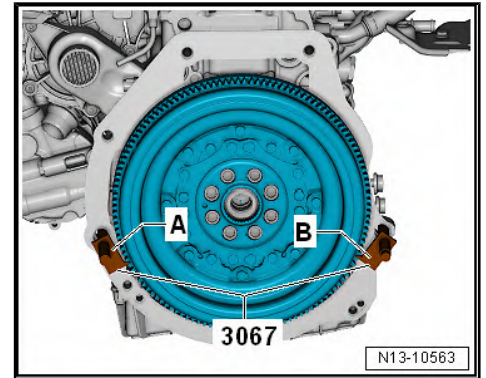

- ◆ Depth gauge - VAS 6082-

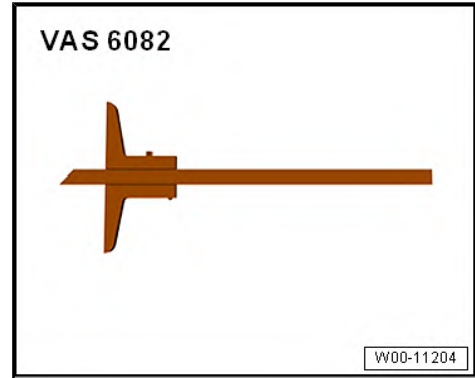

- ◆ Bolt M6 x 35 (3 units)
- ◆ Bolt M7 x 35 (2 units)

### Pressing out sealing flange with sender wheel

- Gearbox removed.
- Remove flywheel ⇒ [page 68](#) .

### Note

*For illustration purposes, the following procedure is shown with the engine removed.*

- Unhook intermediate plate on sealing flange and on the dowel sleeves -arrows-.
- Rotate crankshaft by turning bolt for toothed belt sprocket until crankshaft is positioned at "TDC", as shown in illustration.
- Remove sump ⇒ [page 161](#) .
- Remove engine speed sender - G28- ⇒ [page 443](#) .

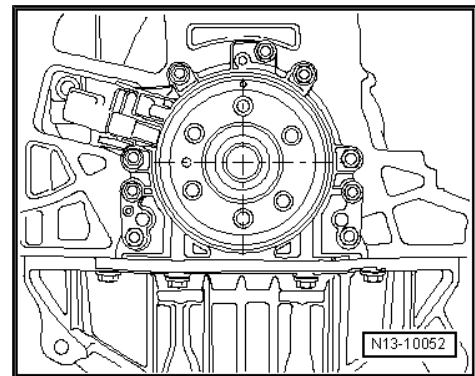
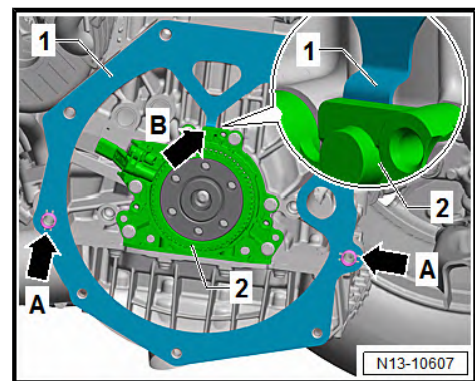

- Unscrew bolts -arrows- for sealing flange -1-.

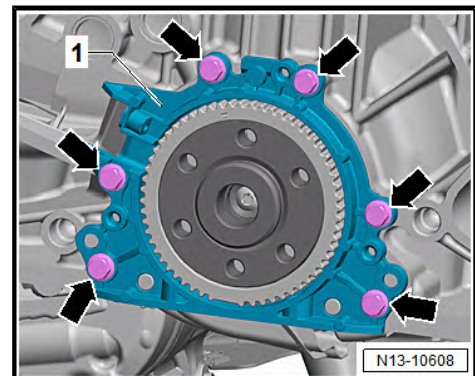

- To press off, screw 3 bolts M6x35 into sealing flange -1- -arrows-.
- Turn the screws in an alternating manner by a maximum of 1/2 a turn into the sealing flange.
- Remove sealing flange -1- together with sender wheel -2-.

**To insert the sealing flange with sensor wheel**

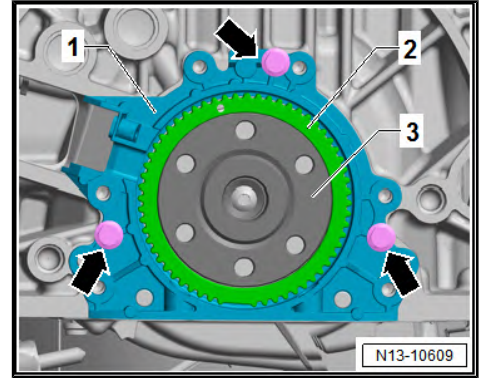

 **Note**

- ◆ The sealing flange with PTFE oil seal is fitted with a sealing lip support ring -2-. This pressure ring fulfils the function of an assembly sleeve and cannot be removed before fitting.
- ◆ Sealing flange and sender wheel -1- must not be separated or rotated out of position after removal from packaging.
- ◆ The sender wheel -1- is held in its installation position on the assembly tool - T10134- => [page 71](#) by a locating pin.
- ◆ Sealing flange and oil seal form a unit and may only be replaced together with the sender wheel.
- ◆ The assembly tool - T10134- is held in the correct position relative to the crankshaft by a guide pin which is inserted into a hole in the crankshaft => [page 71](#) .

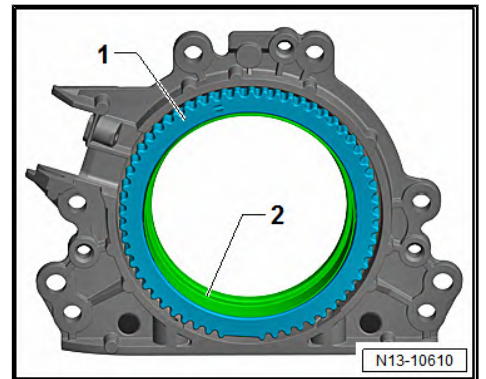

**Structure of the assembly tool - T10134- :**

- A - Attachment surface
- B - Nut
- C - Assembly housing
- D - Locating pin
- E - Hexagon socket head bolts (2x)
- F - Guide pin for diesel engines (red handle)
- G - Guide pin for diesel engines (black handle)
- H - Knurled screws (3x)
- I - Inner side

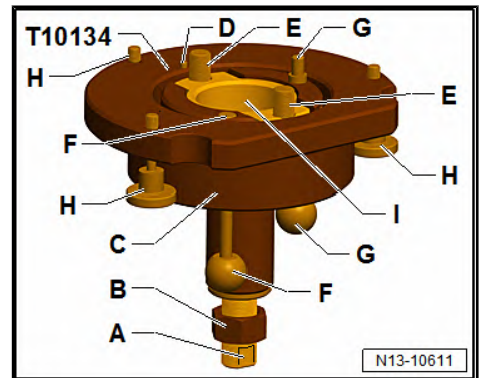

**Securing sealing flange with sender wheel onto assembly tool - T10134- :**

- Screw on nut -B- until just before it touches the clamping surface -A- of the threaded spindle.

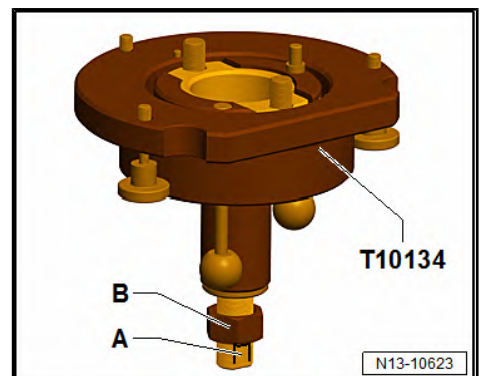

- Clamp assembly tool - T10134- in a vice -1- on tightening flats -A- of threaded spindle.
- Press assembly housing -C- downward so that it rests against nut -B-.
- Inner part of assembly device and installation socket must be level with each other.

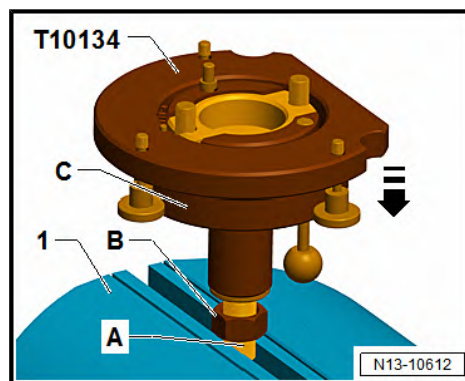

- If fitted, remove the securing clip -arrow- from new sealing flange.

**i** Note

*Do not take the sensor wheel out of the sealing flange or rotate it out of position.*

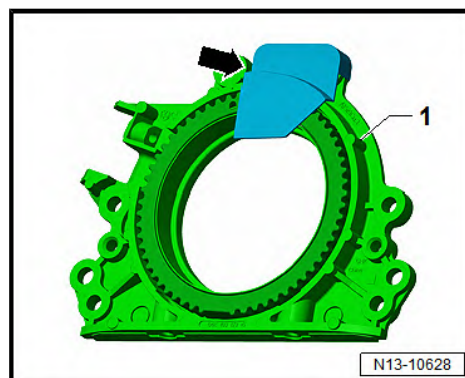

- Secure the sealing flange by the front on a flat, clean surface.
- Press sealing lip support ring -1- downwards in direction of -arrow- until it touches flat surface.

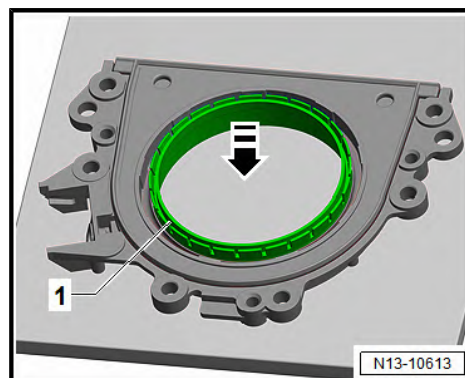

- The upper edge of the sealing lip support ring -1- must be flush with the front edge of the sealing flange -2- -arrows-.

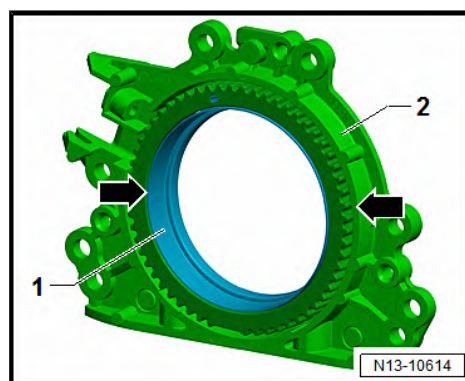

- Place front side of sealing flange -1- on assembly tool - T10134- so that locating pin -D- is seated in hole -3- in sender wheel -2-.
- Only 2 of the 3 knurled screws -H- can be screwed in. The knurled screw on the engine speed sender's -G28- side must not be screwed in.
- Ensure that sealing flange lies flat on assembly tool.

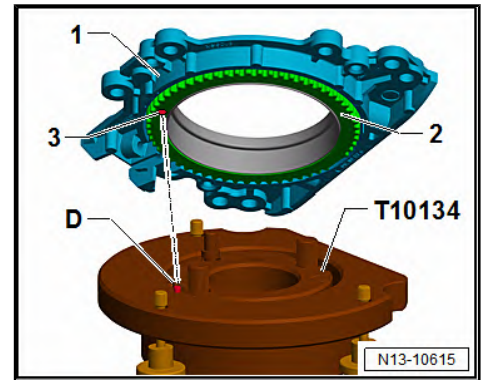

- Screw knurled screws -H- onto sealing flange -1-.
- When tightening, press sealing flange -1- and sealing lip support ring -2- against surface of assembly tool - T10134- .
- This prevents the locating pin from slipping out of the sensor wheel hole.
- Ensure that the sender wheel remains fixed in the assembly tool when installing the sealing flange.

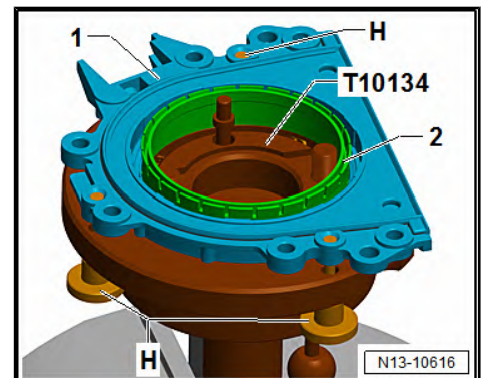

#### Securing assembly tool - T10134- with sealing flange -1- on crankshaft flange:

- Crankshaft flange must be free of oil or grease.
- Engine is at "TDC" position.
- Screw nut -B- to end of threaded spindle.
- Press threaded spindle of assembly tool - T10134- in direction of -arrow- until nut -B- makes contact with assembly housing -C-.
- Point the flat part of the installation socket towards the sealing surface of the engine block in contact with the oil sump.
- Fasten assembly tool - T10134- together with the sealing flange -1- to the crankshaft flange -2-.
- For this purpose, screw the hexagon socket head bolt -E- with a hexagon key approx. 5 rotations into the crankshaft flange.
- Push guide pin for petrol engines (red handle)-F- into crankshaft flange.

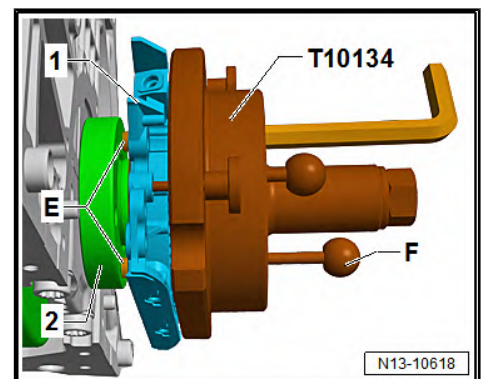
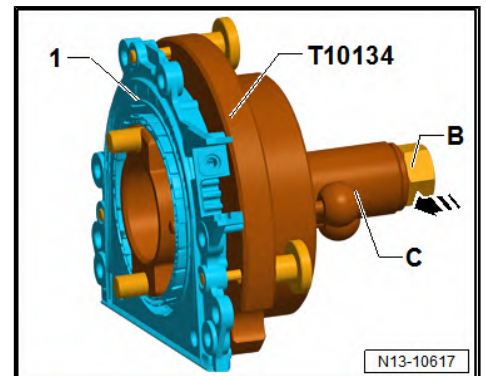

- Screw two bolts M6 x 35 mm -2- into cylinder block to guide the sealing flange -1-.

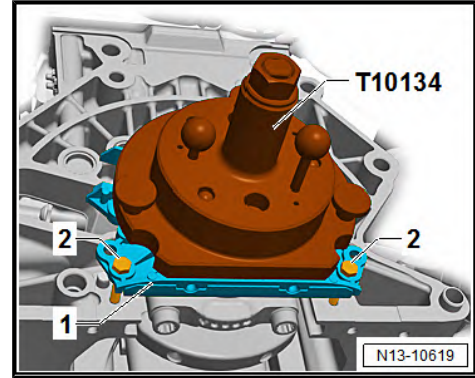

#### Securing assembly tool - T10134- on crankshaft flange:

- Press the assembly housing -C- by hand in the direction of the -arrow- until the sealing lip support ring -1- lies on the surface of the crankshaft flange -2-.
- Check that the guide pin for petrol engines (red handle) -F- is seated correctly in the hole in the crankshaft. This ensures that sender wheel reaches its final installation position.

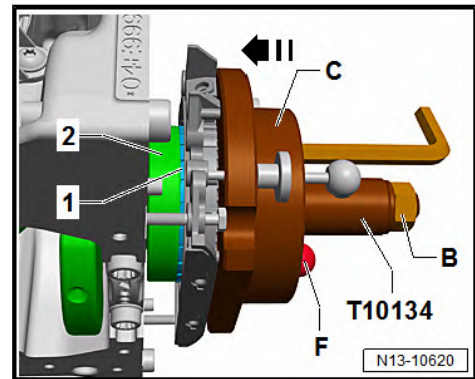

#### Note

*The guide pin for diesel engines (black handle) must not be inserted in threaded hole of crankshaft.*

- Tighten the two hexagon socket head bolts on assembly tool hand-tight.
- Screw nut -B- onto threaded spindle by hand until it lies against assembly housing -C-.

#### Pressing sender wheel onto the crankshaft flange using assembly tool - T10134- :

- Tighten nut -B- on assembly tool - T10134- to 35 Nm.
- A small gap must be present between cylinder block and sealing flange after tightening nut to 35 Nm -1-.

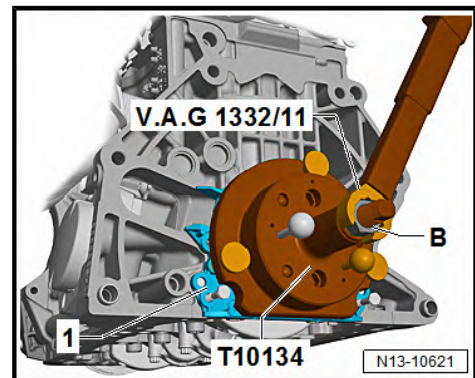

#### Checking sender wheel installation position on crankshaft:

- Screw nut -B- to end of threaded spindle.
- Remove both bolts -2- from cylinder block.
- Screw out the guide pins for petrol engines (red handle) -F- from the crankshaft flange.
- Unscrew knurled screws -H- from sealing flange -1-.
- Unbolt assembly tool - T10134- from crankshaft flange (remove hexagon socket head bolts -E- from crankshaft flange).
- Remove the pressure ring from the sealing lip.

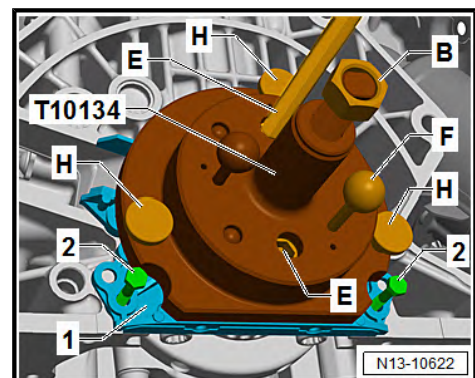

- Apply depth gauge - VAS 6082- to crankshaft flange -2-.
- Measure distance between crankshaft flange -2- and sender wheel -1-.

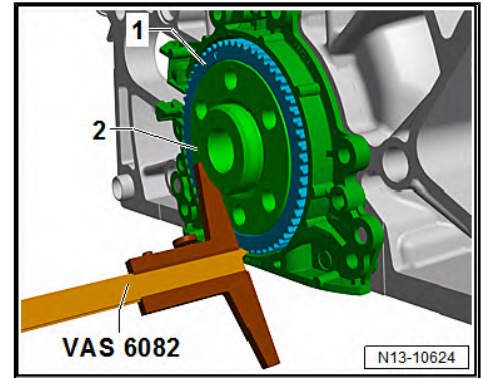

- Measure distance -a- between crankshaft flange -2- and sensor wheel -1-.
- Specification: Distance -a- = 0.5 mm
- Press sensor wheel in further if distance is too small  
 => [page 75](#) .
- If reading matches specification, continue with assembly  
 => [page 76](#) .

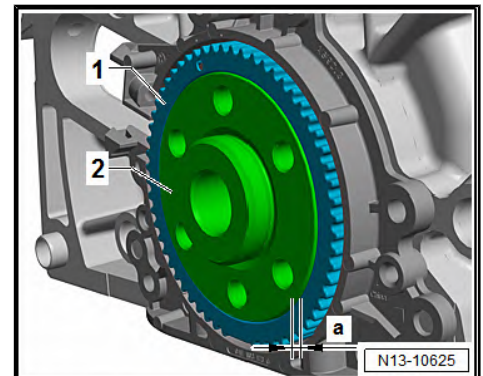

**Re-pressing sender wheel:**

- Secure assembly tool - T10134- on crankshaft flange -1-.
- Take care to ensure that the locating pin of the assembly tool - T10134- is seated in the hole in the sender wheel.
- Hand-tighten hexagon socket head bolts -E-.
- Slide assembly tool - T10134- onto sealing flange -1- by hand.
- Screw nut -B- onto threaded spindle by hand until it touches assembly tool - T10134- .
- Push guide pin for petrol engines (red handle)-F- into crankshaft flange.
- Screw knurled screws -H- onto sealing flange -1-.
- Screw two bolts M6 x 35 mm -2- into cylinder block to guide the sealing flange.

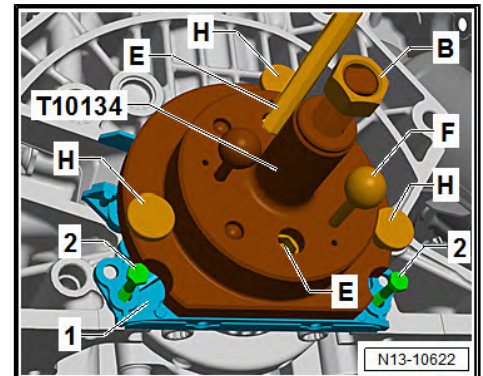

- Tighten nut -B- on assembly tool - T10134- to 40 Nm.
- Check the sender wheel installation position on the crankshaft again ⇒ [page 74](#) .
- Tighten nut on assembly tool - T10134- to 45 Nm if distance is too small.
- Check the sender wheel installation position on the crankshaft again ⇒ [page 74](#) .

### Assembling

The assembly is done in the reverse order; note the following:

- Tighten sealing flange bolts ⇒ [page 68](#) .
- Install oil pan ⇒ [page 161](#) .
- Intermediate plate installation ⇒ [page 68](#)
- Install flywheel ⇒ [page 68](#) .

### Specified torques

- ◆ ⇒ [Fig. ““Sealing flange on gearbox side - Prescribed torque and tightening sequence””, page 68](#)
- ◆ ⇒ [“2.1 Exploded view - cylinder block, gearbox end”, page 67](#)
- ◆ ⇒ [“1.1 Exploded view - sump/oil pump”, page 159](#)
- ◆ ⇒ [“1.1 Assembly overview - glow plug system”, page 443](#)

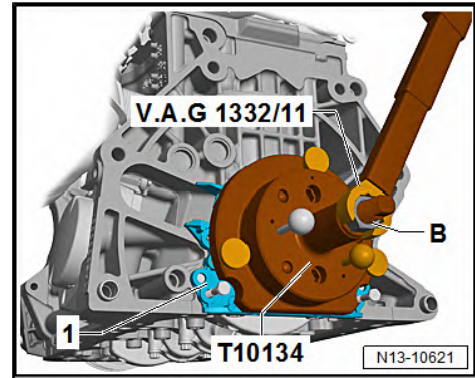

## 3 Crankshaft

⇒ [“3.1 Assembly overview - crankshaft”, page 77](#)

⇒ [“3.2 Crankshaft dimensions”, page 78](#)

⇒ [“3.3 Renewing needle bearing in crankshaft”, page 78](#)

⇒ [“3.4 Measure axial play of crankshaft”, page 80](#)

### 3.1 Assembly overview - crankshaft



- ◆ *The assembly overview refers exclusively to engines without balancer shafts.*
- ◆ *The crankshaft must not be removed for engines with balance shafts. The balance shaft system must not be dismantled.*

#### 1 - Cylinder block

#### 2 - Bearing shell

- for cylinder block with lubricating groove
- Renew used bearing shells

#### 3 - Toothed belt sprocket

- For oil pump drive
- Not available as separate replacement part

#### 4 - Bearing shell

- for bearing cap without lubricating groove
- Renew used bearing shells

#### 5 - Bolt.

- Always renew after removing
- 65 Nm + turn +90° further

#### 6 - Bearing cap

- Bearing cap 1: belt pulley end.
- Bearing cap 3 with recesses for thrust washers.
- Installation position: retaining lugs on bearing shells in cylinder block and bearing caps must be on the same side

#### 7 - Attack washer

- For bearing 3
- Different types for cylinder block and bearing cap
- Note location

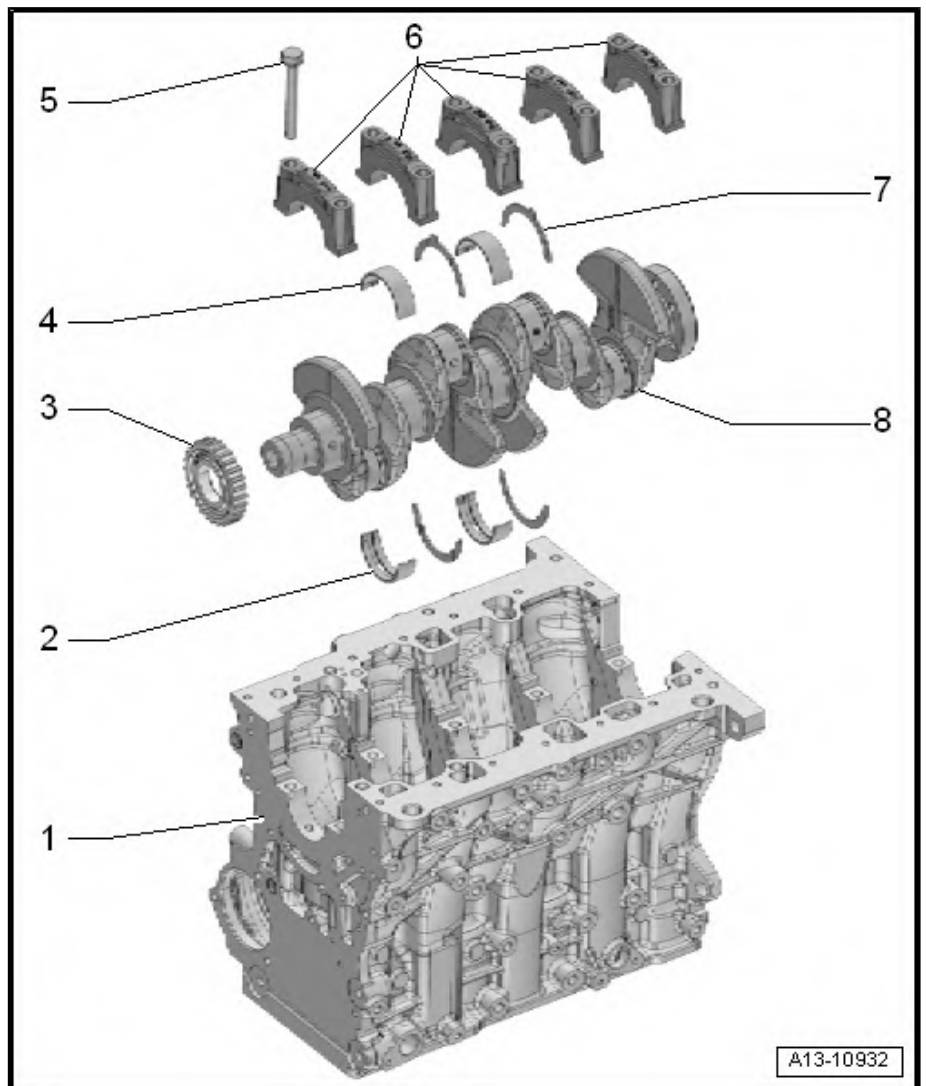

## 8 - Crankshaft

- There should be no needle bearing fitted in the crankshaft on vehicles with manual gearbox; remove needle bearing if necessary ⇒ [page 78](#)
- A needle bearing must be fitted in the crankshaft on vehicles with dual-clutch gearbox; install needle bearing if not yet fitted ⇒ [page 78](#) .
- Measuring axial clearance ⇒ [page 80](#)
- Check radial clearance with Plastigage.
- New radial clearance: 0.03 ... 0.08 mm. Wear limit: 0.17 mm
- Do not rotate the crankshaft when checking the radial clearance
- Crankshaft dimensions ⇒ [page 78](#) .

## 3.2 Crankshaft dimensions

Honing dimension	∅ Bank pin mm	∅ Conrod journal mm	
		1.6 l engine	2.0 l engine
Basic dimension	54.00 $-0,022$ $-0,042$	47.80 $-0,022$ $-0,042$	50.90 $-0,022$ $-0,042$

## 3.3 Renewing needle bearing in crankshaft

Only for vehicles with DSG gearbox

Special tools and workshop equipment required

- ◆ Kukko - 22/1- adapter



- ◆ Puller - Kukko 21/2-



◆ Punch - VW 207 C-



 Note

*Vehicles with dual clutch gearbox, the needle bearing must be installed in rear end of crankshaft.*

**Prerequisites:**

- Always replace needle bearing -arrow- if the engine and transmission are being separated.
- The front edges of the internal puller must not be chipped.

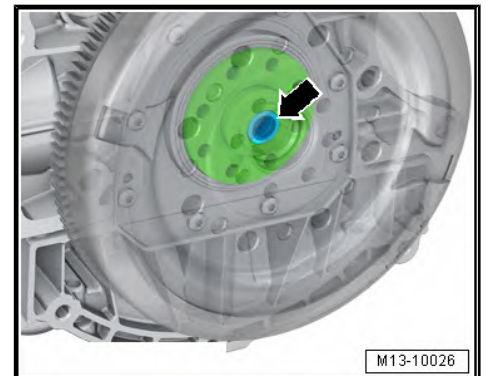

**Pulling out needle roller bearing**

- Pull needle bearing -1- out of crankshaft -2- using a standard pulling tool e. g. Kukko - 21/2- and counter support e.g. Kukko - 22/1- .
- The internal puller must be positioned behind the needle roller and cage assembly -arrow-.

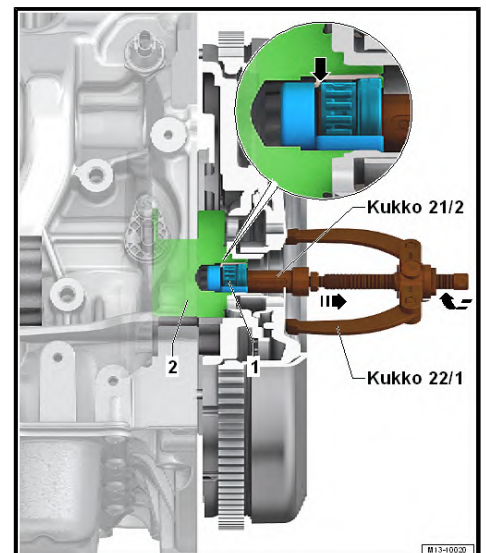

## Installation



### Note

*On open bearings, the lettering on the needle bearing must be visible when installed. Bearings which are closed on one side must be driven in with the closed end facing towards the crankshaft.*

- Clean bearing seat in crankshaft and grease lightly.
- Drive needle bearing into crankshaft to installation depth using drift - VW 207 C- .

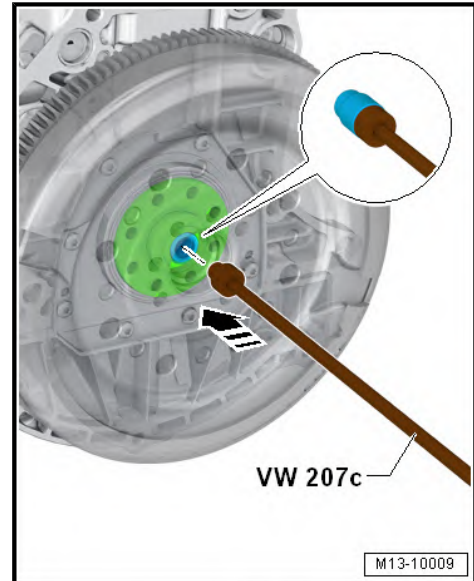

Installation depth: Dimension -a- = 2.0 mm.



### Note

*If the needle bearing is inadvertently driven in too far, it must be renewed because it will be damaged when it is pulled out again.*

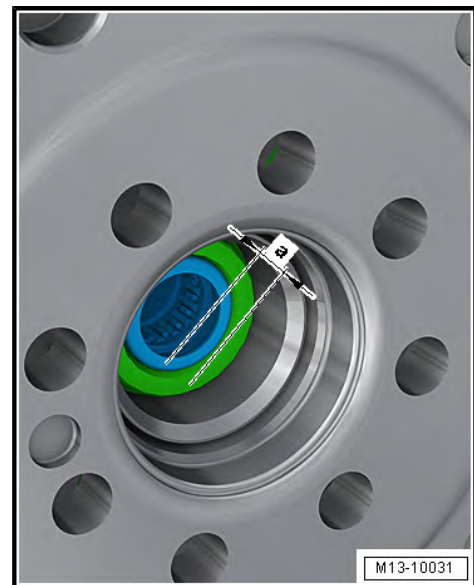

## 3.4 Measure axial play of crankshaft

Special tools and workshop equipment required

- ◆ Universal dial gauge bracket - VW 387-

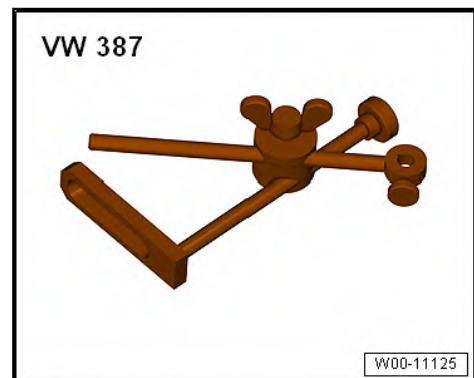

◆ Dial gauge - VAS 6079-

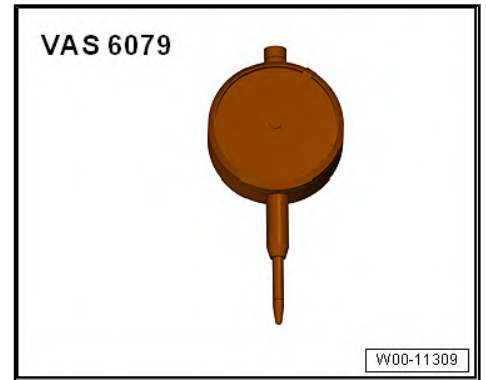

**Operation process**

- Secure the measuring gauge - VAS 6079- using the universal dial gauge holder - VW 387- to the engine block as shown in the illustration and position against the crankshaft.
- Press crankshaft against dial gauge by hand.
- Set the dial gauge to "0".
- Push crankshaft away from dial gauge and read off measured value.

**Axial clearance:**

- New: 0.07 ... 0.17 mm
- Wear limit: 0.37 mm

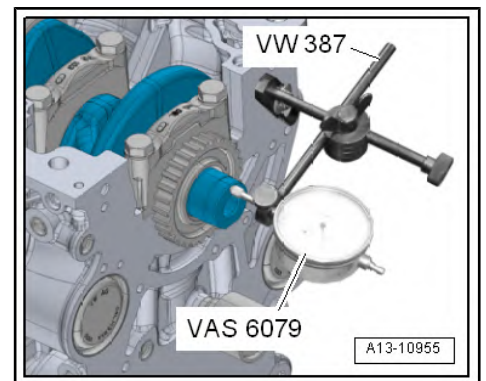

## 4 Pistons and conrods

⇒ [“4.1 Exploded view - pistons and conrods”, page 82](#)

⇒ [“4.2 Removing and installing pistons”, page 84](#)

⇒ [“4.3 Measuring piston projection at TDC”, page 86](#)

⇒ [“4.4 Checking pistons and cylinder bores”, page 88](#)

⇒ [“4.5 Checking radial clearance of conrod bearings”, page 89](#)

### 4.1 Exploded view - pistons and conrods



#### Note

*Oil jets and pressure release valve* ⇒ [page 84](#)

#### 1 - Bolts

- Renew
- Lubricate threads and contact surface
- 30 Nm + turn +90° further

#### 2 - Bearing cap

- Observe installation position
- Due to the cracking method used to separate the bearing cap from the conrod in manufacture, the caps only fit in one position and only on the appropriate conrod
- Mark conrod and cylinder allocation in colour -B-
- Installation position: Show markings -A- face towards pulley end

#### 3 - Bearing shells

- Installation position ⇒ [page 84](#)
- Renew used bearing shells
- Note version: Upper bearing shell (closest to piston) is constructed from a more wear-resistant material. Distinguishing feature on new bearing shells: black marking on bearing surface near joint
- Check for secure seating.

#### 4 - Conrod

- With industrially cracked conrod bearing cap

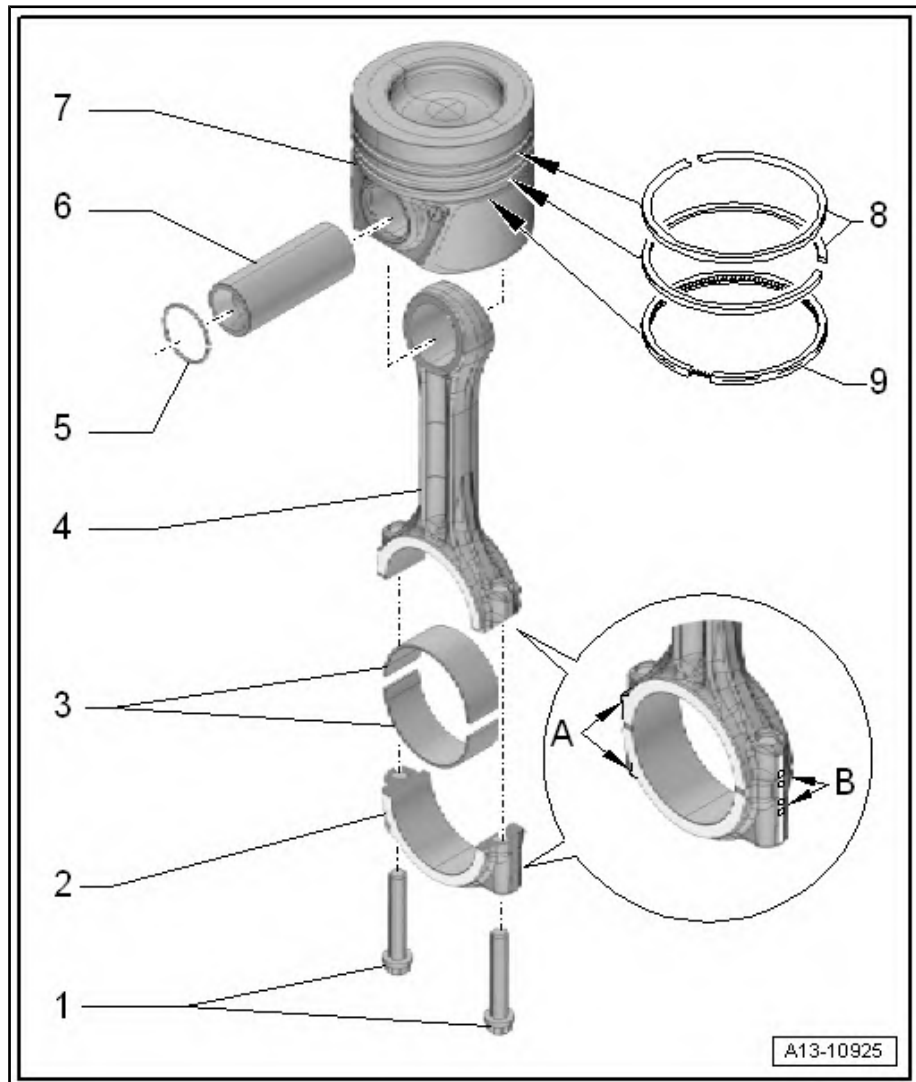

- only renew as a complete set
- Mark conrod bearing cap and cylinder allocation in colour -B-
- Axial play, wear limit: 0.37 mm
- Measuring radial clearance ⇒ [page 89](#)
- Separating parts of new conrod ⇒ [page 84](#)
- Installation position: Markings -A- face towards pulley end

#### 5 - Circlip

- 2 off
- Renew

#### 6 - Piston pin

- Removing and fitting ⇒ [“4.2 Removing and installing pistons”, page 84](#)

#### 7 - Piston

- With combustion chamber
- Renew piston if cracking is visible on piston crown or piston skirt
- Mark installation position and cylinder number ⇒ [page 83](#)
- Removing and fitting ⇒ [page 84](#)
- Checking pistons and cylinder bores ⇒ [page 88](#)
- Measuring piston projection at “TDC” ⇒ [page 86](#)

#### 8 - Compression rings

- Measuring ring gap ⇒ [page 89](#)
- Measuring clearance ⇒ [page 89](#)
- Use piston ring pliers (commercially available) to remove and install
- Installation position: marking “TOP” or side with lettering faces towards piston crown
- Offset gaps by 120°

#### 9 - Oil scraper ring

- Measuring ring gap ⇒ [page 89](#)
- Measuring clearance ⇒ [page 89](#)
- remove and fit using pliers adapted for piston rings
- Installation position: marking “TOP” or side with lettering faces towards piston crown
- Offset gap 120° from bottom compression ring

#### Installation position of pistons and allocation of piston/cylinder

 **Caution**

*Risk of damage to piston crown.*

◆ *If you intend to re-install used pistons, mark the cylinder number on the piston crown using paint. Do not use indentation, scratches, notches, or similar to mark piston crown.*

- The arrow on the piston crown must point to the pulley side -arrow-.

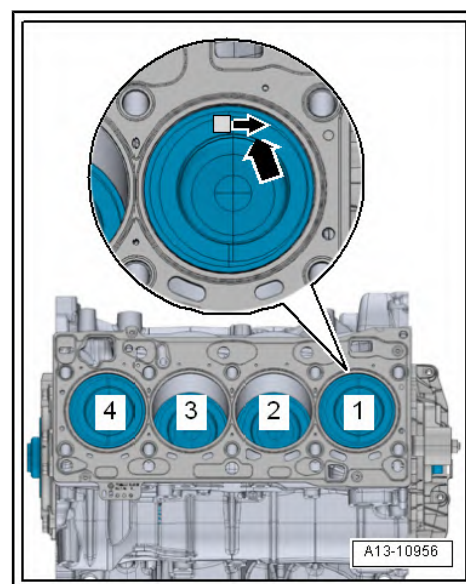

### Installation position of bearing shells in conrods

- Insert bearing shells centrally in conrod/conrod bearing cap.
- Distance -a- = 2.5 mm

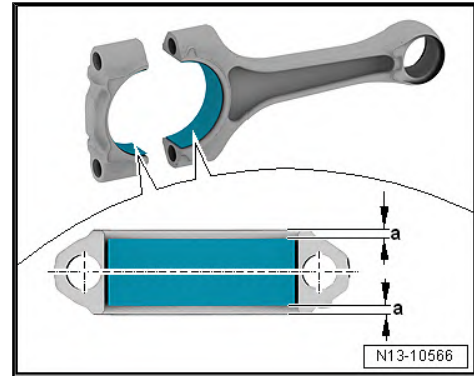

### Separate new conrod

On new conrods it is possible that conrod and conrod bearing cap are very firmly bonded. Proceed as follows if the conrod bearing cap cannot be removed by hand:

- To avoid any risk of damage, the conrod should only be clamped lightly in a vice using jaw covers as shown in illustration.
- The conrod is clamped in position below the dotted line.
- Unscrew bolts -arrows- approx. 5 turns.

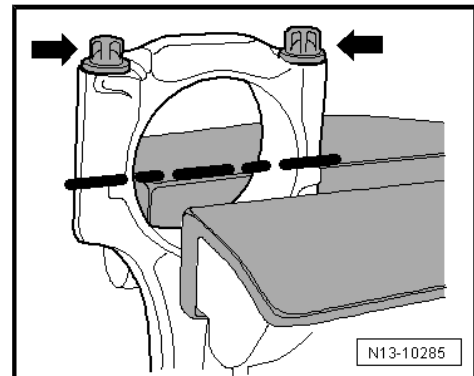

- Using a plastic hammer, carefully knock conrod bearing cap loose -arrow-.

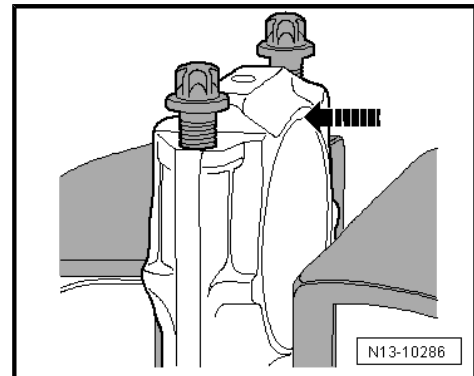

### Oil spray jet and pressure relief valve

- 1 - Bolt with pressure relief valve - 27 Nm
  - 2 - Oil spray jet (for cooling of piston)
- Installation position: align locating edge of oil spray jet with machined surface of engine block.

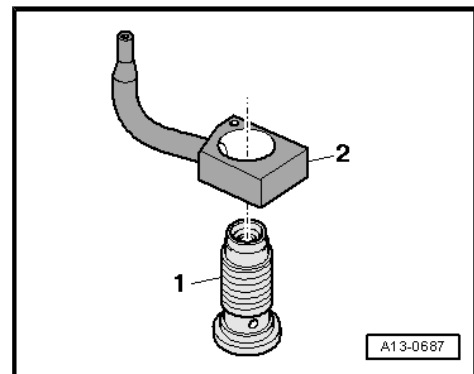

#### Caution

*Risk of damage to oil spray jets.*

- ◆ *Do not bend oil spray jets.*
- ◆ *Check that oil spray jets adequate clearance after re-installing pistons.*
- ◆ *Bent oil spray jets must be renewed.*

## 4.2 Removing and installing pistons

Special tools and workshop equipment required

◆ Mandrel - VW 222 A-

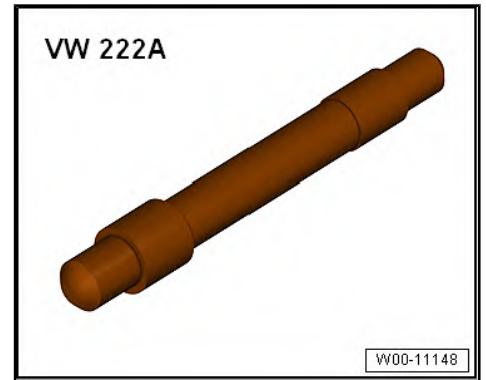

◆ Piston ring clamp, commercially available

### Removal

- Engine secured to engine and gearbox support ⇒ [page 37](#) .
- Remove cylinder head ⇒ [page 94](#) .
- Remove oil pump ⇒ [page 166](#) .
- Mark installation position and matching of conrod bearing caps to cylinder and to conrods for reinstallation ⇒ [Item 2 \(page 82\)](#) .
- Unbolt conrod bearing caps.
- Pull out pistons upwards with conrods.

 **Note**

*If the piston pin moves sluggishly, heat the piston to approx. 60 °C.*

- Take circlip out of piston pin boss.
- Use drift - VW 222 A- to drive out piston pin.

### Installation

Installation is carried out in the reverse order; note the following:

 **Note**

*Renew the bolts tightened with specified tightening angle.*

- Oil running surfaces of bearing shells.
- Install pistons using piston ring clamp.

Installation position

- ⇒ [page 83](#) Piston
- Bearing shells in conrods ⇒ [page 84](#)
- Install conrod bearing caps according to markings.
- Install oil pump ⇒ [page 166](#) .
- Installing the cylinder head ⇒ [page 94](#) .

### Specified torques

- ◆ ⇒ [“4.1 Exploded view - pistons and conrods”, page 82](#)

### 4.3 Measuring piston projection at TDC



**Note**

- ◆ *Piston projection at "TDC" must be measured when installing new pistons or a short engine.*
- ◆ *If the measured values for piston projection are not the same for all pistons, use the highest value to determine the correct cylinder head gasket size.*
- ◆ *Install the appropriate cylinder head gasket depending upon piston projection, according to following table:*

**Special tools and workshop equipment required**

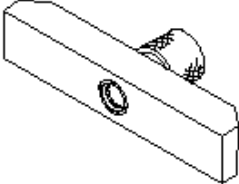
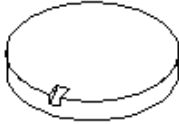
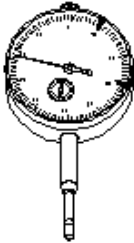
<p>VW 382/7</p> 	<p>VW 385/17</p> 
<p>VAS 6079</p> 	
	<p>G13-0064</p>

- ◆ Measuring bridge -VW 382/7- from measuring tool - VW 382-
- ◆ Measuring plate -VW 385/17- from universal measuring tool - VW 385-
- ◆ Dial gauge - VAS 6079-

### Operation process

- Secure dial gauge - VAS 6079- with measuring bridge - VW 382/7- and measuring plate -VW 385/17- to cylinder block as shown in illustration.
- Measure piston projection at two points marked with -arrows- for each piston. Measure at the front and back of the pistons on the longitudinal axis of the engine.
- Install the appropriate cylinder head gasket depending upon piston projection, according to following table:

Piston projection above top surface of cylinder block mm	Identification Holes
0.91 ... 1.00	1
1.01 ... 1.10	2
1.11 ... 1.20	3

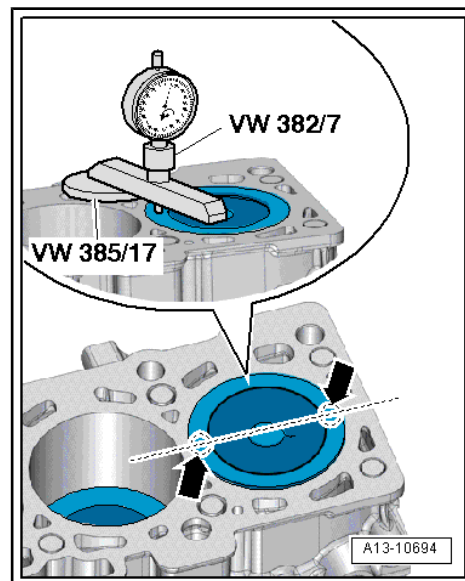

### Cylinder head identification

- 1 - Part number
- 2 - Ignore
- 3 - Holes

**i** Note

*If the measured values for piston projection are not the same for all pistons, use the highest value to determine the correct cylinder-head gasket size.*

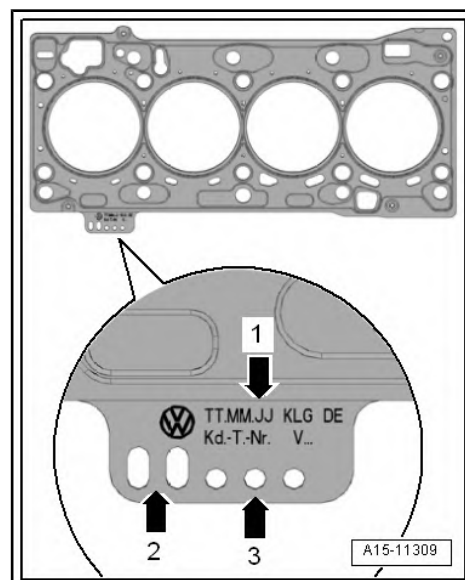

## 4.4 Checking pistons and cylinder bores

### Checking piston

- Using an outer micrometer (75 ... 100 mm), measure approx. 15 mm from the lower edge, perpendicular to the piston pin axis.
- Maximum deviation from nominal dimension: 0.04 mm.



#### Note

- ◆ Check piston skirt coating for wear. Also check pistons and cylinder bores for carbon deposits in general.
- ◆ If piston skirt is cracked, renew piston.

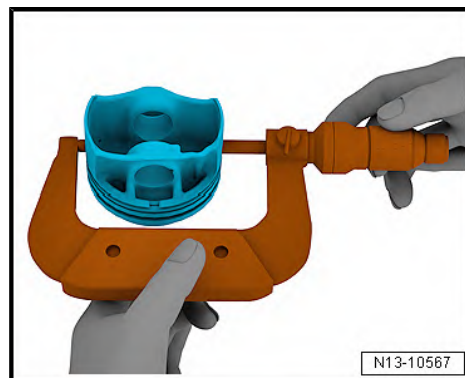

Piston Ø mm		
Nominal dimension	1.6 l	79.42 <sup>1)</sup>
	2.0 l	80.92 <sup>1)</sup>
<ul style="list-style-type: none"> <li>• <sup>1)</sup> Dimensions include coating (thickness 0.02 mm). The coating will wear down.</li> </ul>		

### Measuring cylinder bore

- Use a cylinder gauge - VAS 6078- to take measurements at 3 points criss-cross in transverse direction -A- and in longitudinal direction -B-.
- Maximum deviation from nominal dimension: 0.10 mm.



#### Note

Check cylinder wall for wear of honed surfaces, scratches and other defects.

Cylinder bore Ø (in mm)		
Nominal dimension	1.6 l	79.5
	2.0 l	81.3



#### Note

Measuring the cylinder bores must not be done when the cylinder block is mounted to the engine and gearbox stand - VAS 6095-, as incorrect measurements may result.

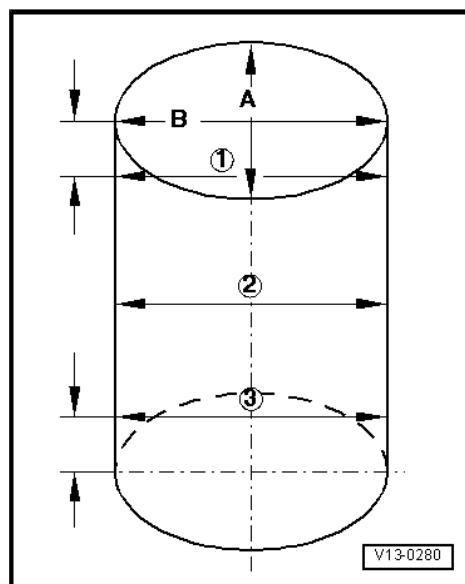

### Measuring piston ring gap

- Insert the ring through the lower cylinder opening from above at right angles to the cylinder wall so that it is about 15 mm from the cylinder edge.
- Push in using a piston without piston rings.

Segment ring	New mm	Wear limit mm
1st compression ring	0.3 ... 0.40	0.55
2nd compression ring	0.20 ... 0.45	0.95
Oil scraper ring	0.25 ... 0.50	0.75

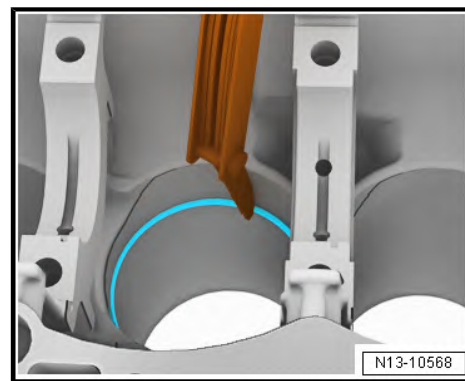

### Measuring ring-to-groove clearance

- Clean annular groove of piston before check.

Segment ring	New mm	Wear limit mm
1st compression ring	0.06 ... 0.09	0.08
2nd compression ring	0.05 ... 0.08	0.08
Oil scraper ring	0.03 ... 0.06	0.08

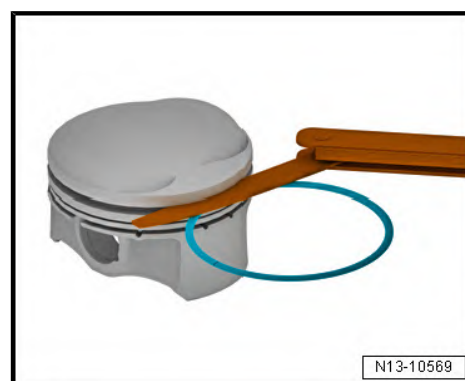

## 4.5 Checking radial clearance of conrod bearings

### Special tools and workshop equipment required

- ◆ Plastigage thread

### Operation process

- Remove conrod bearing cap. Clean bearing cap and bearing journal.
- Place a length of Plastigage corresponding to the width of the bearing on the bearing journal or bearing shell.
- Fit conrod bearing caps and without turning further angle tighten to 30 Nm without rotating crankshaft.
- Remove conrod bearing cap again.
- Compare width of Plastigage with dimension.

### Radial play:

- Wear limit: 0.08 mm.
- Renew conrod bolts.

## 15 – Cylinder head, valve gear

### 1 Cylinder head

⇒ [“1.1 Exploded view - cylinder head”, page 90](#)

⇒ [“1.2 Assembly overview - cylinder head cover”, page 92](#)

⇒ [“1.3 Removing and installing cylinder head”, page 94](#)

⇒ [“1.4 Cylinder head cover: removing and installing”, page 103](#)

⇒ [“1.5 Removing and installing seals for injectors”, page 106](#)

⇒ [“1.6 Removing and installing camshaft housing”, page 107](#)

⇒ [“1.7 Check compression pressure”, page 112](#)

#### 1.1 Exploded view - cylinder head

##### 1 - Cylinder block

##### 2 - Cylinder head gasket

- Renew  
⇒ [“1.3 Removing and installing cylinder head”, page 94](#)
- Cylinder head identification ⇒ [page 92](#)
- If renewed, change coolant and engine oil

##### 3 - Cylinder head

- Removing and fitting ⇒ [page 94](#)
- To avoid the possibility of glow plug damage, only set down cylinder removed on a foam pad
- check for deformation ⇒ [page 91](#)
- Must not be machined
- Before installing, check that the two dowel sleeves for centring cylinder head are fitted on cylinder block
- If renewed, change coolant and engine oil
- Information on plug ⇒ [page 91](#)

##### 4 - Dowel pin

- For camshaft housing

##### 5 - Bolt.

- Renew
- Sequence when loosening ⇒ [page 100](#) .
- Tightening torque and sequence ⇒ [page 92](#) .

##### 6 - Bolt.

- 20 Nm

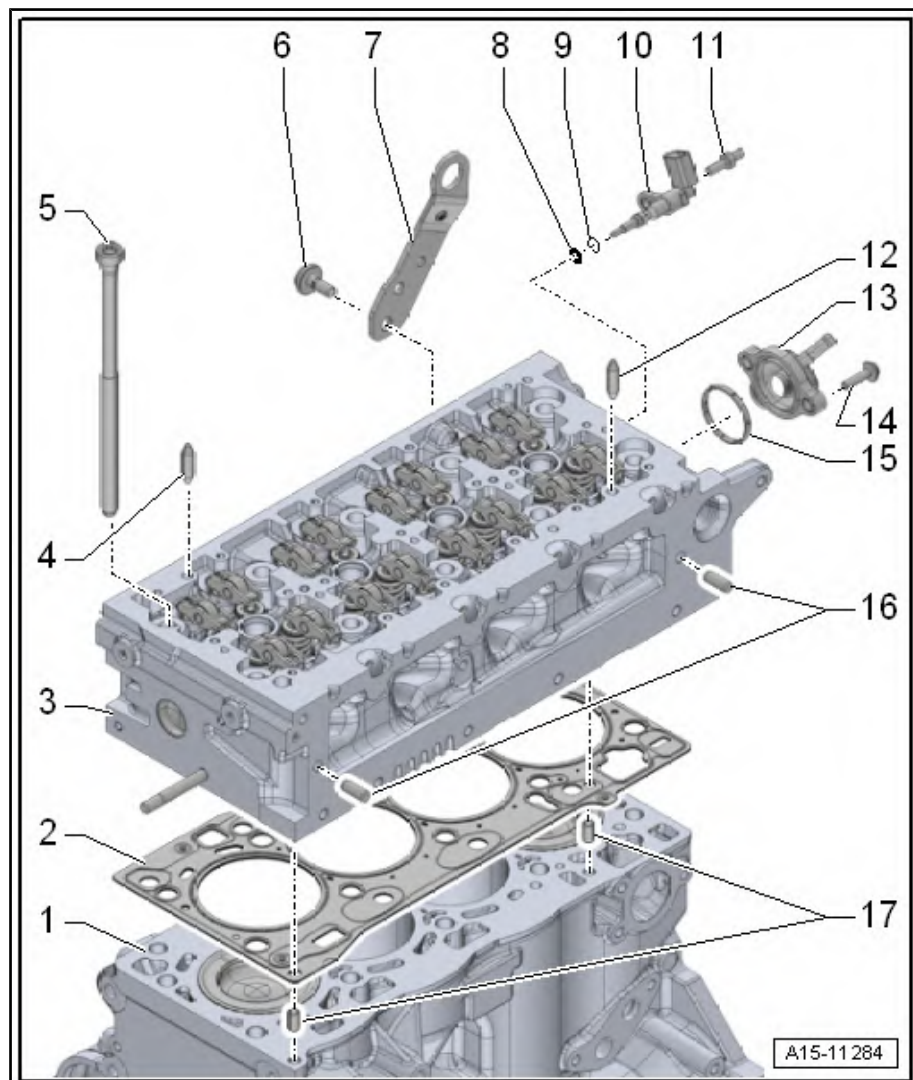

## 7 - Engine lifting eye

## 8 - Spacer ring

- Renew if damaged.

## 9 - O-ring

- Renew
- Lubricate with coolant

## 10 - Coolant temperature sensor - G62-

- Removing and fitting ⇒ [page 206](#)

## 11 - Two-threaded bolt

- Tightening torque ⇒ [Item 4 \(page 194\)](#)

## 12 - Dowel pin

- For camshaft housing

## 13 - Connection

- For coolant hoses

## 14 - Bolt.

- 10 Nm

## 15 - Oil seal

- Renew

## 16 - Dowel pin

- For intake manifold with charge air cooler

## 17 - Dowel sleeves

### Plug in cylinder head:



#### Note

- ◆ *There is a plug with a seal in the cylinder head on the gearbox end (not illustrated).*
- ◆ *Plug M10 x 18.*
- ◆ *Tightening torque: 15 Nm*
- ◆ *For allocation, refer to ⇒ Electronic Parts Catalogue*

### Checking cylinder head for distortion

- Use straight edge 500 mm - VAS 6075- and feeler gauge to measure cylinder head for distortion at several points.
- Max. permissible distortion: 0.1 mm.

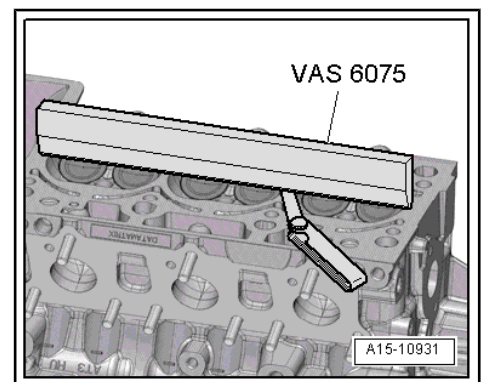

#### Note

*Cylinder heads must not be reworked on TDI engines.*

### Cylinder head identification

- 1 - Part number
- 2 - Disregard
- 3 - Holes



#### Note

Depending on the projection measurement of the pistons, gaskets of varying thickness are fitted ⇒ [page 86](#) . When renewing only the cylinder head gasket, the new gasket should have the same identification as the old one.

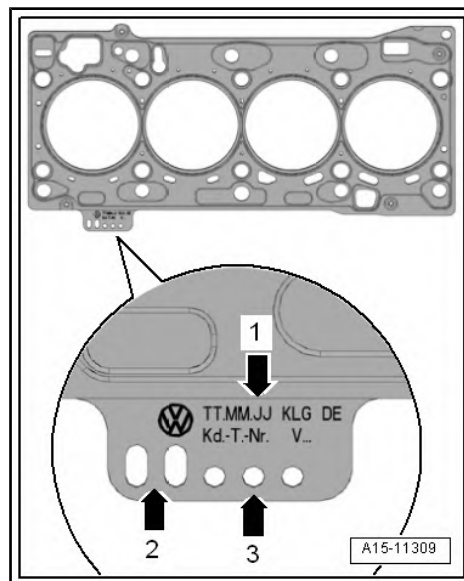

### Cylinder head - tightening torque and sequence



#### Note

Renew the bolts tightened with specified tightening angle.

- Tighten the bolts in steps in the indicated sequence:

stage	Bolts	Tightening torque / tightening angle
1st	-1 ... 10-	30 Nm
2nd	-1 ... 10-	65 Nm
3.	-1 ... 10-	Turn 90° further
4.	-1 ... 10-	Turn 90° further

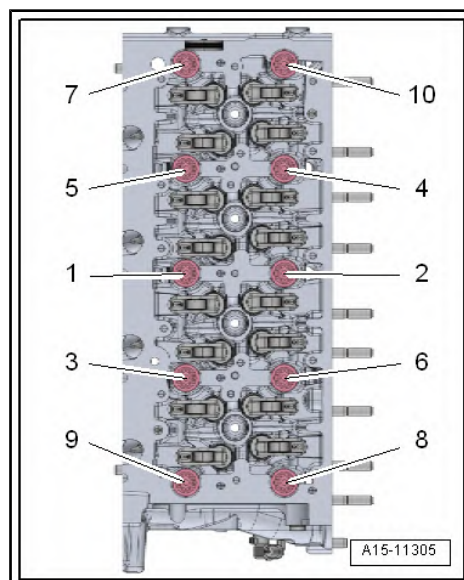

## 1.2 Assembly overview - cylinder head cover

**1 - Seal**

- Renew if damaged or leaking

**2 - Cylinder head cover:**

- Removing and fitting  
 ⇒ [page 103](#)

**3 - O-ring**

- Renew

**4 - Sealing plug**

**5 - Bracket/bearing/support**

- For electrical wiring

**6 - Bolt.**

- 8 Nm

**7 - Nipple/nozzle/grommet**

- In cylinder head cover

**8 - Clamping piece**

**9 - Bolt.**

- Tightening torque  
 ⇒ [page 297](#)

**10 - O-ring**

- Renew

**11 - Hose**

- for crankcase breather
- Press the release buttons to remove

**12 - Fuel return line**

**13 - O-ring**

- Renew

**14 - Injector**

- Observe rules for cleanliness ⇒ [page 13](#) .
- Assembly overview ⇒ [page 297](#)

**15 - O-ring**

- Renew

**16 - Insulating seal**

- Renew

**17 - Oil seal**

- For injector
- Renew ⇒ [page 106](#)

**18 - Vacuum hose**

**19 - Sealing cap**

**20 - Seal**

- For filler cap

**21 - Nipple/nozzle/grommet**

**22 - Bolt.**

- Renew seal if damaged.
- Tightening torque and sequence ⇒ [page 94](#) .

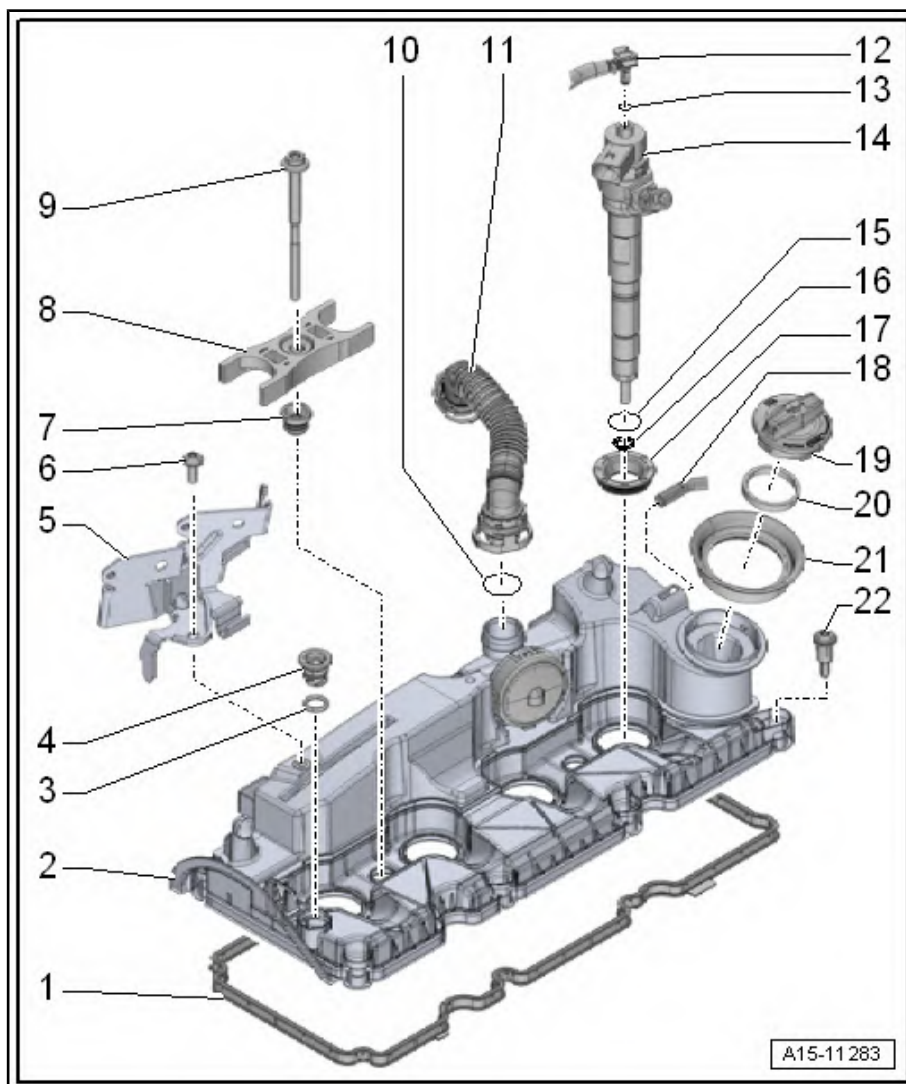

### Cylinder head cover - tightening torque and sequence

- Tighten bolts for cylinder head cover in the sequence -1 ... 7- to 9 Nm.

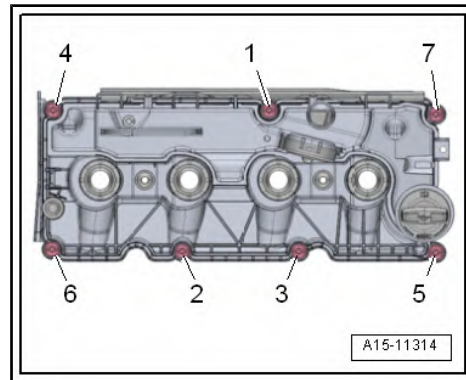

## 1.3 Removing and installing cylinder head

### Special tools and workshop equipment required

- ◆ Pressing-off lever - 80 - 200-

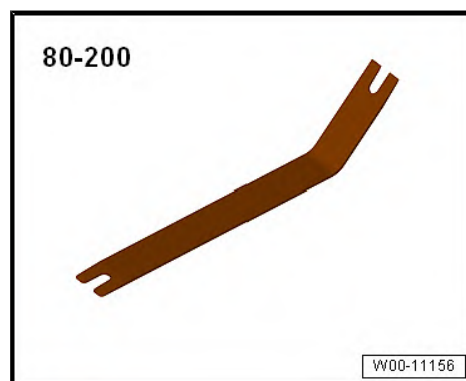

- ◆ Hose clip pliers - VAS 6362-



- ◆ Transport lock - T10404-

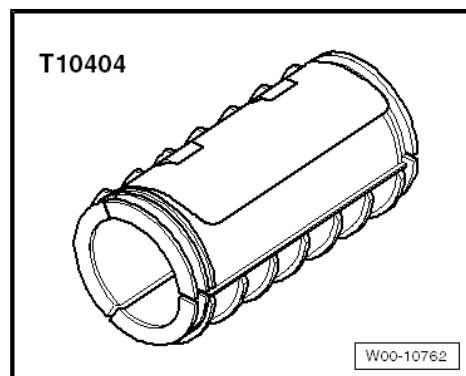

## Removal



*Re-attach all heat insulation sleeves at the same locations when re-installing.*

- Remove engine cover. ⇒ [page 56](#)
- For reasons of space, remove the air filter housing together with the intake hose ⇒ [page 321](#) .
- Remove coolant pipes (top front) ⇒ [page 209](#) .
- Remove the rear coolant pipe ⇒ [page 217](#) .
- Remove coolant pipes (left-side) ⇒ [page 215](#) .
- Remove front exhaust pipe ⇒ [page 378](#) .
- Detach toothed belt from camshaft ⇒ [page 132](#) .

### LHD vehicles with pressure differential sender - G505- :

- Open heat insulation sleeve -1-.
- Take and unplug electrical connector -4- out of bracket, move electrical wiring clear.
- Unplug electrical connectors -3, 5- and move wiring harness clear.
- Remove bolt -2- and move bracket with pressure differential sender - G505- towards rear.

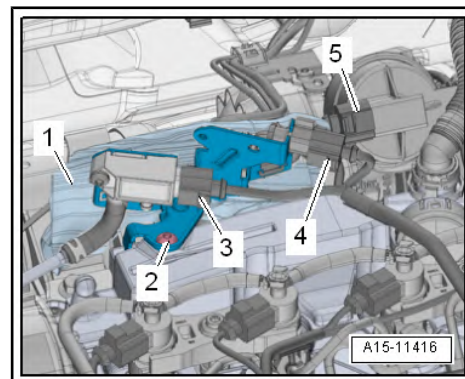

### LHD vehicles with exhaust gas pressure sensor 1 - G450- and pressure differential sender - G505- :

- Open heat insulation sleeve -1-.
- Take electrical connector -5- out of bracket, unplug it and move electrical wiring clear.
- Disconnect electrical connectors -3, 4 and 6- and move wiring harness clear.
- Unscrew the bolt -2-.
- Move bracket with pressure differential senders back.

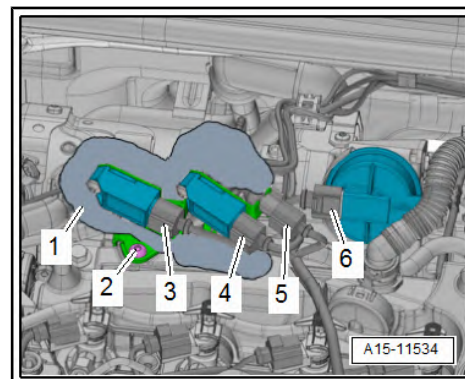

### All vehicles (continued):

- Press the release buttons on the crankcase breather hose -1- and remove it from the cylinder head cover.
- Unscrew bolt -3-, swing air pipe with inlet connection -2- to rear and pull off from turbocharger.

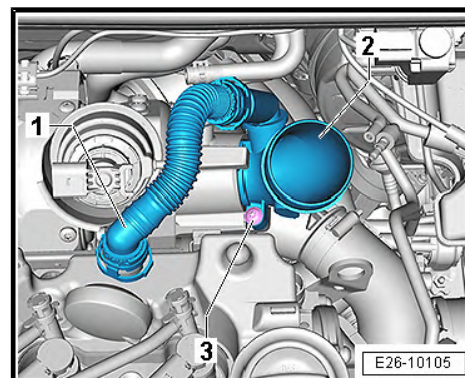

- Unscrew bolts -arrows- and remove resonator -1-.

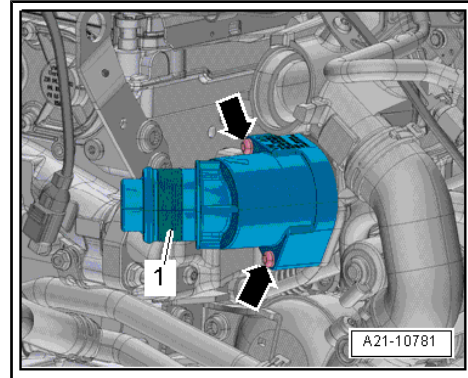

- Loosen the hose clip -1-, remove the coolant hose.
- Loosen bolt -2-, remove bolt -3- and pivot coolant pipe clear to one side.

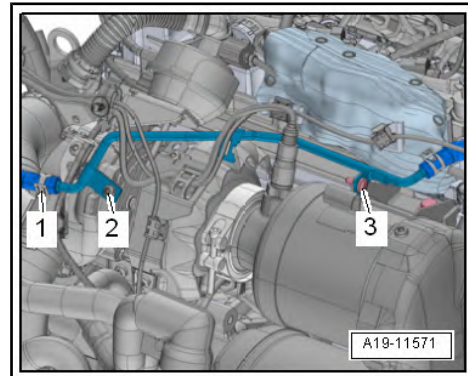

- Unplug electrical connectors and move wiring clear:
- 2 - For exhaust gas temperature sender 4 - G648-
- 3 - For exhaust gas temperature sender 3 - G495-
- 4 - For Lambda probe 1 before catalytic converter - GX10- .

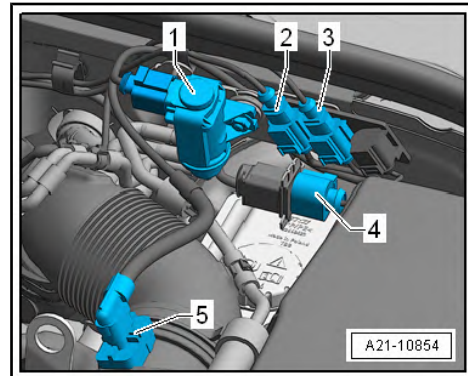

- Push heat insulation sleeve to one side and unplug electrical connector -5-.
- Loosen the hose clip -3-, remove the air intake hose.
- Loosen the hose clip -4-, remove the coolant hose.
- Remove bolt -1- and loosen bolt -2-.

 **Note**

*Ignore -item 6-.*

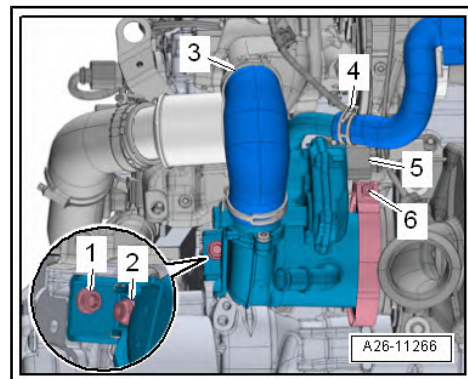

- Loosen bolt -1- and remove screw-type clip.
- Loosen centre hex stud -2- and move coolant pipe slightly towards rear.
- Remove bolts -arrows- and press the emission control module and exhaust gas recirculation cooler to the rear.

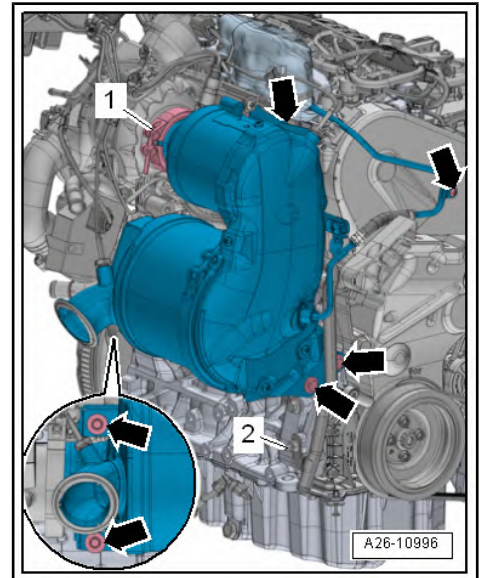

- Unscrew bolt -2- and union nut -4-.
- Remove bolts -3, 5- and detach oil return pipe.

 **Note**

*Item -1- can be disregarded.*

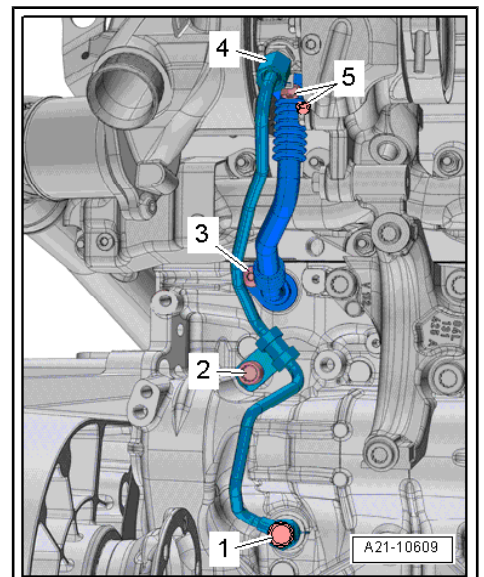

- Remove bolt -2- and loosen bolts -1, 3, 4-.

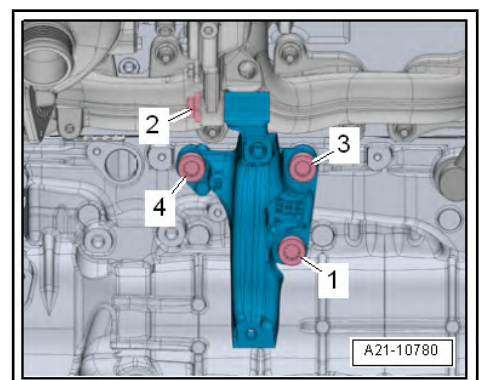

**Vehicles with variable valve timing:**

- Unplug electrical connectors -1, 3-.
- Loosen the clamp -2-.

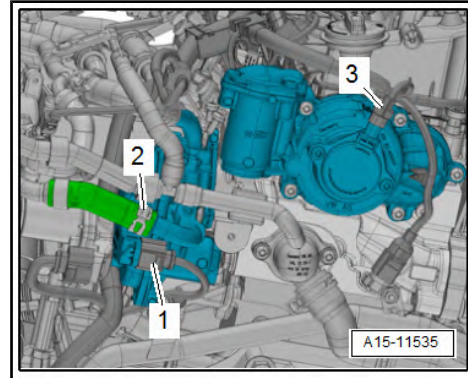

**All vehicles (continued):**

- Unplug electrical connectors and move clear:
- 1 - For charge air temperature sender after charge air cooler - G811-
- 3 - For charge pressure sender - G31-
- 4 - For intake air temperature sender - G42-
- 5 - for throttle valve control unit - J338-
- Unscrew and remove the bolts -2, 7-, remove the coolant hose -6-.

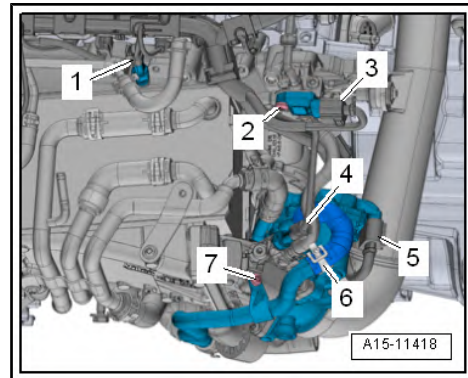

- Remove bolt -1- for dipstick guide tube.
- Remove bolts -2, 3- for bracket for intake manifold.

**Vehicles with engine codes CRLB, CRMB, CRKB, CUNA, CXXA, CXXB, DBKA, CRLD**

- Remove throttle valve control unit - J338- ⇒ [page 328](#)

**All vehicles (continued):**

- Remove camshaft housing ⇒ [page 107](#) .

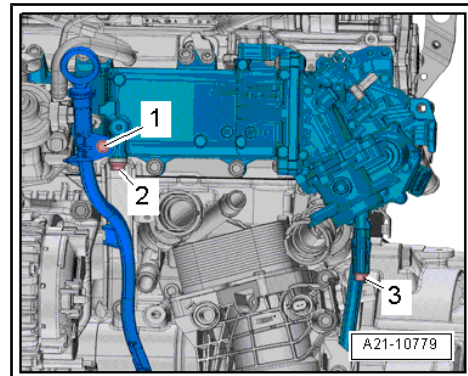

- Unplug electrical connector -3- and detach from cover -2-.
- Unscrew bolt -1- and remove cover.

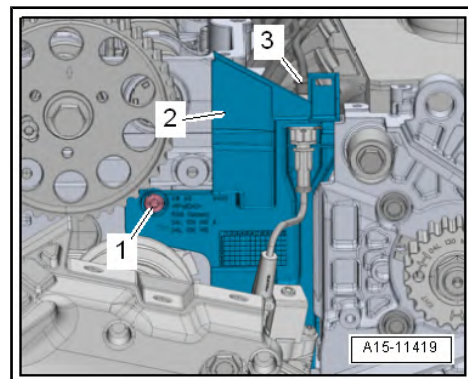

- Release catch -arrow- and disconnect vacuum hose -1-.
- Disconnect vacuum hose -2-.
- Unscrew the bolt -3-.

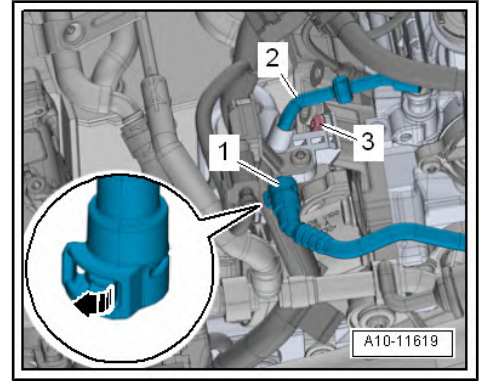

- Unplug electrical connector -2- for coolant temperature sender - G62- .
- Loosen the hose clip -1-, remove the coolant hose.
- Disconnect vacuum hose -3-.

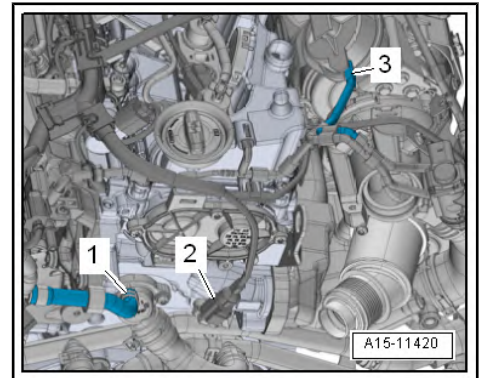

- Detach electrical connectors at glow plugs ⇒ [page 443](#) .
- Move electrical wiring harness clear to side.

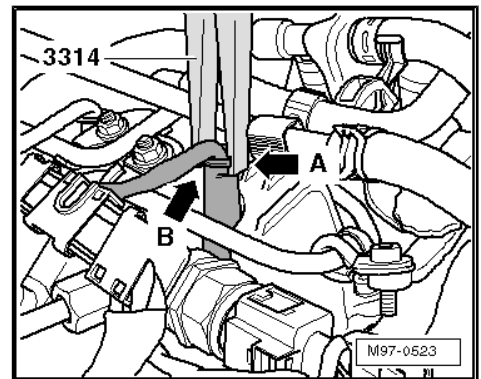

- Slacken cylinder head bolts in the sequence -1 ... 10-.



### Note

*A second mechanic is required to remove the cylinder head.*

- Swivel cylinder head to left and out of rear toothed belt cover and detach tensioning roller at the same time.
- Take care not to damage oil return line for turbocharger.
- Take care to place the cylinder head down without bending the oil return line. If necessary, place a block of wood below exhaust manifold.



### Caution

***Risk of damage to glow plugs when putting down cylinder head.***

- ◆ ***After removal, the cylinder head must not be put down on the gasket side with the glow plugs still installed, because the glow plugs project slightly beyond the gasket surface***

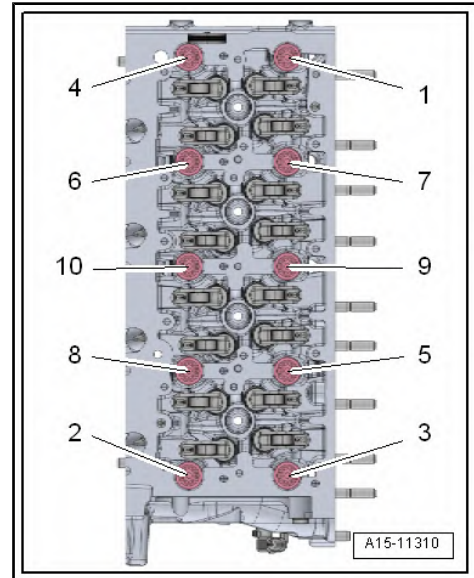

### Installation



### Caution

***Risk of damage to sealing surfaces.***

- ◆ ***Carefully remove sealant residue from cylinder head and cylinder block.***
- ◆ ***Ensure that no scoring or scratching is produced.***

***Risk of damage to cylinder block.***

- ◆ ***No oil or coolant must be allowed to remain in the blind holes for the cylinder head bolts in the cylinder block.***

***Risk of leaks at cylinder head gasket.***

- ◆ ***Carefully remove sealant residue from cylinder head and cylinder block. Ensure that no scoring or scratching is produced.***
- ◆ ***Carefully remove any remaining emery and abrasive material.***
- ◆ ***Do not remove the new cylinder head gasket from its packing until immediately before its installation.***
- ◆ ***Handle the cylinder head gasket very carefully to prevent damage to the silicone coating or the indented area of the gasket.***

***Risk of damage to valves and piston crowns after working on valve gear.***

- ◆ ***Turn the crankshaft carefully at least 2 rotations to ensure that none of the valves make contact when the starter is operated.***

 **Note**

- ◆ *Cylinder heads must not be reworked on TDI engines.*
- ◆ *Renew bolts that are tightened with turning further angle after each removal.*
- ◆ *Renew self-locking nuts, seals, gaskets and O-rings after each removal.*
- ◆ *Oil contact surfaces between roller rocker fingers and cams.*
- ◆ *Secure all hose connections with the correct type of hose clips (same as original equipment) ⇒ Electronic parts catalogue .*
- ◆ *After fitting a new cylinder head or cylinder head gasket, change the engine oil and refill the complete cooling system with fresh coolant.*

– Before fitting cylinder head, remove crankshaft stop -T10490- and turn crankshaft against normal direction of rotation until all pistons are positioned approximately equally below “TDC”.

– If not already fitted, install dowel sleeves in cylinder block for centring cylinder block and cylinder head.

– Note cylinder head gasket identification:

- 1 - Part number
- 2 - Ignore
- 3 - Holes

 **Note**

- ◆ *If the cylinder head gasket or cylinder head have been replaced, select the new cylinder head gasket according to the number of holes on the old gasket.*
- ◆ *If parts of the crankshaft assembly have been renewed, the new cylinder head gasket must be selected by measuring the piston projection at “TDC” ⇒ [page 86](#) .*

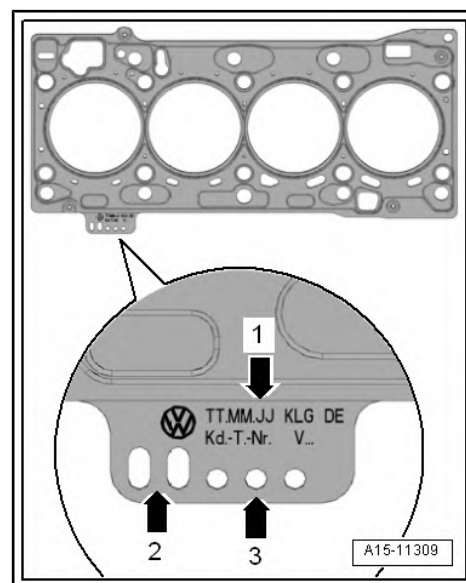

- Fit cylinder head gasket onto dowel sleeves -arrows- in cylinder block.
- Installation position of cylinder head seal: The word “Top” or the spare part number must be facing the cylinder head.



**Note**

*To refit the cylinder head, a second mechanic is required.*

- Insert the cylinder head.
- Fit and tighten cylinder head bolts ⇒ [page 92](#) .



**Note**

*Cylinder head bolts do not have to be torqued down again later after repair work.*

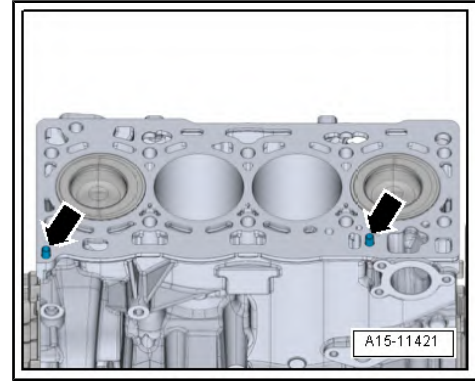

- Then turn the crankshaft in direction of engine rotation until the pin -arrow- on the crankshaft stop -T10490- engages in the sealing flange as the crankshaft rotates.
- Install notched belt (adjusting valve timing) ⇒ [page 125](#) .

Remaining installation sequence carried out in reverse sequence; note the following:

- Install emission control module ⇒ [page 390](#) .
- Install the exhaust pipe ⇒ [page 378](#) .
- Install coolant pipes (left-side) ⇒ [page 215](#) .
- Install coolant pipe (rear) ⇒ [page 217](#) .
- Install coolant pipes (top front) ⇒ [page 209](#) .
- Electrical connections and routing ⇒ Electrical system; Rep. gr. 97 ; Relay carriers, fuse carriers, electronics boxes; Overview of fitting locations - relay carriers, fuse carriers, electronics boxes and ⇒ Current flow diagrams, Electrical fault finding and Fitting locations.
- Install engine cover panel ⇒ [page 56](#) .
- Change the engine oil ⇒ Maintenance ; Booklet 501 .
- Fill cooling system with fresh coolant ⇒ [page 184](#) .

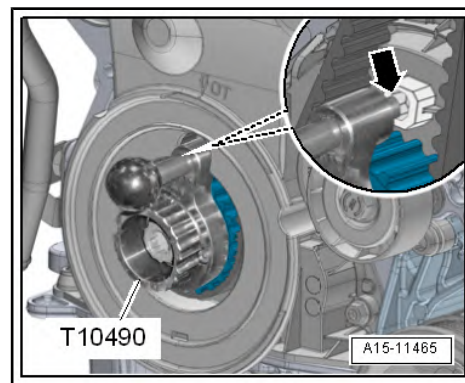

#### Note

- ◆ *After new components have been installed (engine/short engine, cylinder head, camshaft housing or turbocharger) the oil pressure control must be set to max. pressure for approx. 1,000 km. given the function is available in the engine control unit. This will compensate for the increased friction during run-in of new components, and a better transport of wear-related particles is guaranteed. To do this, connect vehicle diagnostic tester, switch on ignition, and select the following menu options:*
- ◆ Oil pressure for entry in the engine

#### Specified torques

- ◆ ⇒ [“1.1 Exploded view - cylinder head”, page 90](#)
- ◆ ⇒ [“1.1 Exploded view - sump/oil pump”, page 159](#)
- ◆ ⇒ [“1.1 Exploded view - turbocharger”, page 252](#)
- ◆ ⇒ [“5.1 Exploded view - intake manifold”, page 323](#)

## 1.4 Cylinder head cover: removing and installing

### Special tools and workshop equipment required

◆ Wrench kit - T10395 A-

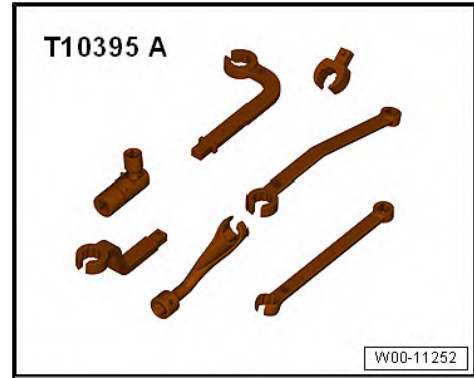

Removal



Note

When fitting the heat protection plate, fit to the same location.

- Remove engine cover. ⇒ [page 56](#)
- Screw out the exhaust gas temperature sender 3 - G495-  
-item 2- with a tool from the set of wrenches - T10395 A- .
- Remove bolt -3-, move pipe clear and push to side.

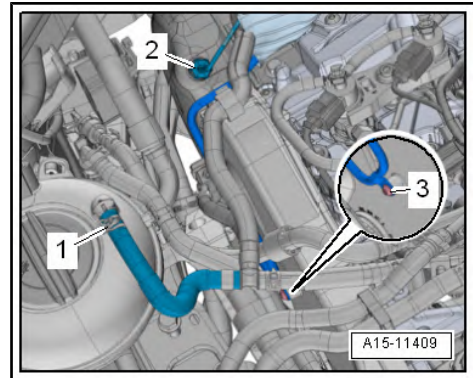

Note

Ignore -item 1-.

- Release catches -arrows-, disengage toothed belt cover (top section) -1- and push towards right.
- Remove injectors ⇒ [page 297](#) .

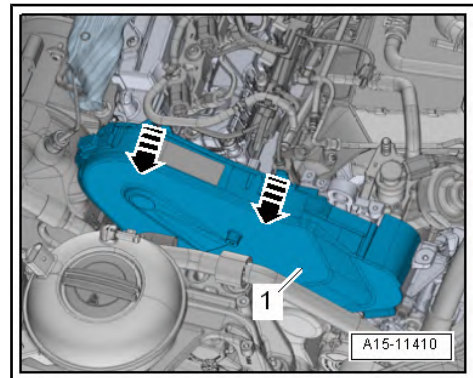

- Press the release button on the crankcase breather hose -1- and remove the hose from the cylinder head cover.
- Lay bare the vacuum hoses at the air pipe -arrows-.
- Loosen the hose clip -3-, remove the air intake pipe from the mass air flow sensor - G70- .
- Unscrew bolt -2-, swing air pipe with inlet connection to rear and pull off from turbocharger.

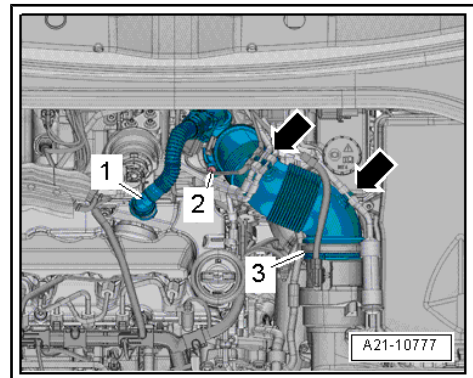

**LHD vehicles with pressure differential sender - G505- :**

- Open heat insulation sleeve -1-.
- Unplug electrical connectors -3, 4, 5- and move wiring harness clear.
- Remove bolt -2- and move bracket with pressure differential sender - G505- towards rear.

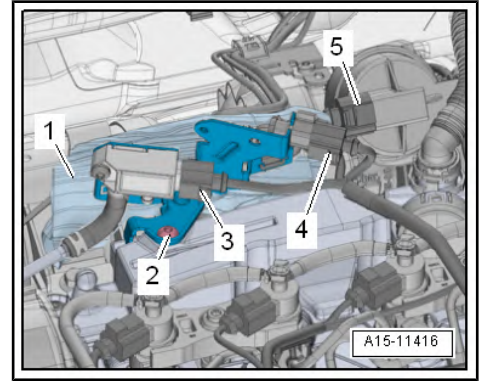

**LHD vehicles with exhaust gas pressure sensor 1 - G450- and pressure differential sender - G505- :**

- Open heat insulation sleeve -1-.
- Take electrical connector -5- out of bracket, unplug it and move electrical wiring clear.
- Disconnect electrical connectors -3, 4 and 6- and move wiring harness clear.
- Unscrew the bolt -2-.

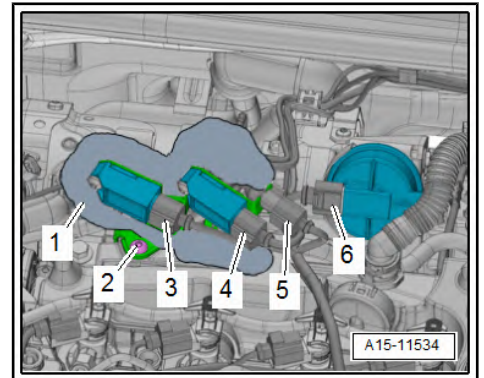

- Disconnect vacuum hose -arrow- and lay it to one side.
- Move bracket with pressure differential senders back.

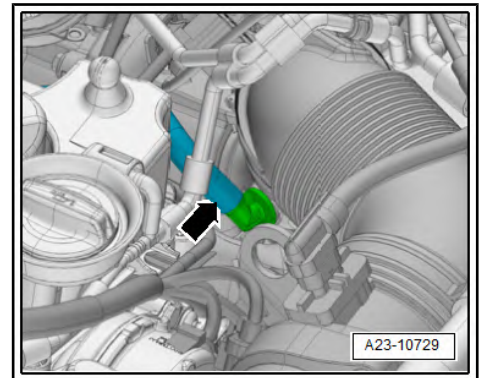

**All vehicles (continued):**

- Disconnect vacuum hose -arrow-.

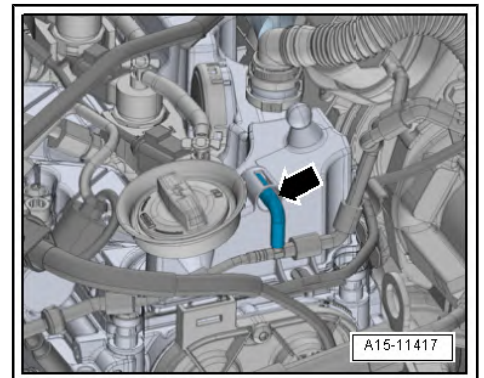

- Slacken cylinder head cover bolts in the sequence -7 ... 1- and remove.
- Remove cylinder head cover.

### Installation

Installation is carried out in the reverse order; note the following:



#### Note

- ◆ Renew O-ring.
- ◆ Renew gasket and bolts for cylinder head cover if damaged or leaking.
- Connect vacuum hose ⇒ [page 295](#) .
- Install engine cover panel ⇒ [page 56](#) .

### Specified torques

- ◆ Cylinder head cover - tightening torque and sequence ⇒ [page 94](#)
- ◆ ⇒ [“2.1 Exploded view - toothed belt cover”, page 114](#)
- ◆ ⇒ [“1.1 Exploded view - turbocharger”, page 252](#)
- ◆ ⇒ [“3.1 Assembly overview - exhaust gas temperature regulation”, page 411](#)
- ◆ ⇒ [“3.1 Assembly overview - injectors”, page 297](#)

## 1.5 Removing and installing seals for injectors

### Special tools and workshop equipment required

- ◆ Coupling - 3390-
- ◆ Tool set - T10133C-

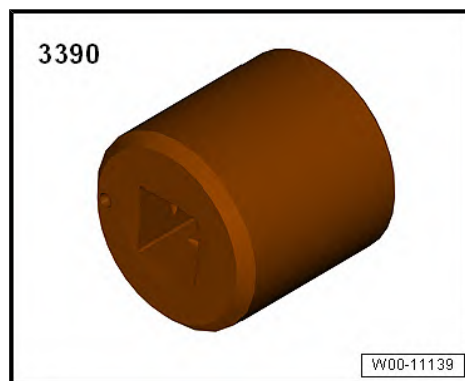
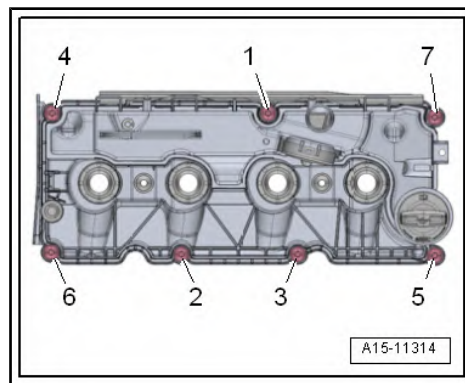

◆ Oil seal extractor - T40195-



**Operation process**

- Remove corresponding injector ⇒ [page 297](#) .
- Screw oil seal extractor - T40195- into seal -1-.
- Fit striker -T10133/3- with adapter -T10133/2- on oil seal extractor, as shown in illustration, and pull out seal upwards by tapping gently.

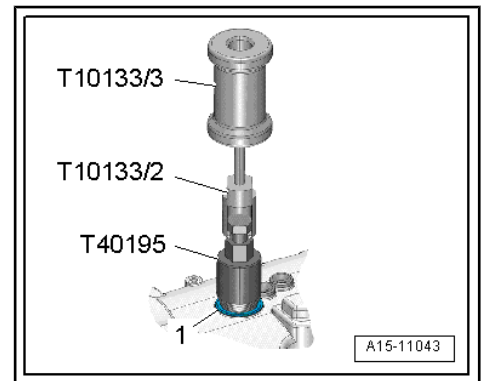

- Press in new seal for injector using carrier - 3390- and short extension -1- from top to stop.

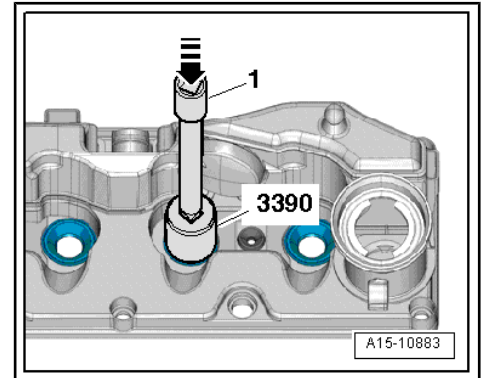

## 1.6 Removing and installing camshaft housing

**Special tools and workshop equipment required**

- ◆ Socket insert XZN 10 - T10501-



- ◆ Torque wrench - V.A.G 1410-

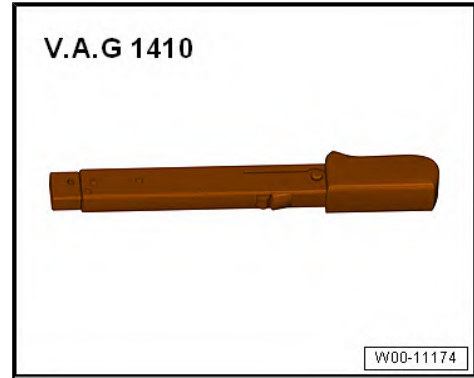

- ◆ Ratchet - V.A.G 1331/1-

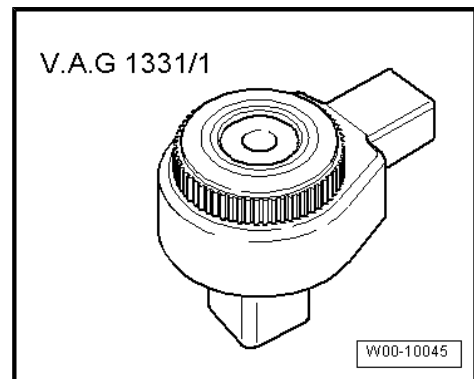

- ◆ Hand drill with plastic brush
- ◆ Protective glasses
- ◆ Sealant ⇒ Electronic parts catalogue

### Removal

- Cylinder head installed.
- Detach toothed belt from camshaft ⇒ [page 132](#) .
- Removing and fitting the cylinder head cover ⇒ [page 103](#) .
- Removing high-pressure accumulator (rail) ⇒ [page 315](#) .
- Remove coolant pipes (left-side) ⇒ [page 215](#) .
- Remove bolts -arrows- and push fuel lines slightly towards front.
- Unplug electrical connector -2- at Hall sender - G40- .

### Note

Ignore -item 1-.

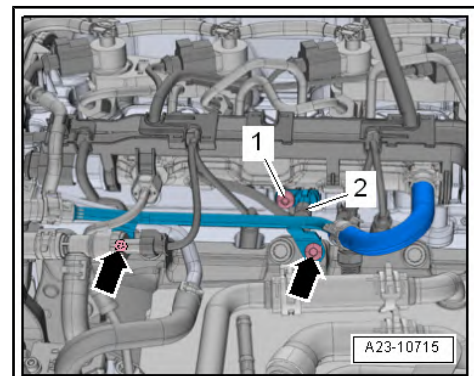

**Vehicles with variable valve timing:**

- Unplug the electrical connector -2-.

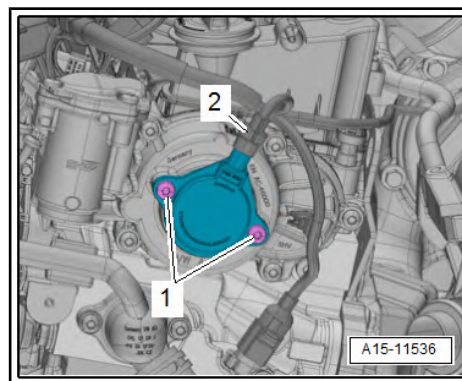

**All vehicles (continued):**

- Remove bolt -1- with bit XZN 10 - T10501- and loosen bolt -2-.

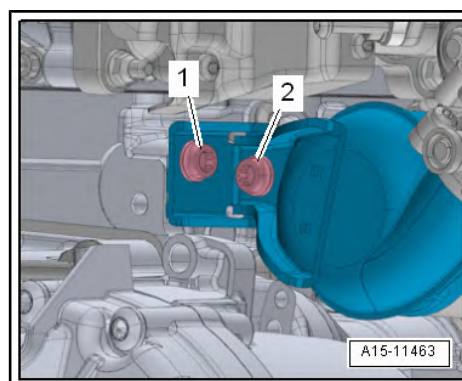

- Loosen bolt -1- and remove screw-type clip.
- Loosen bolts -2- and remove bolts -arrows-.
- Push catalytic converter with particulate filter slightly towards the rear.

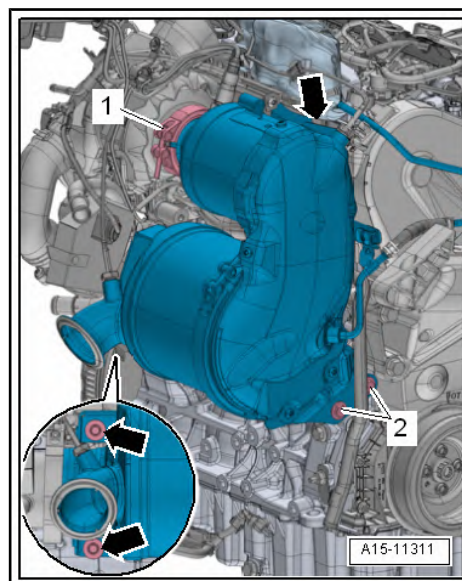

- Slacken camshaft housing bolts in the sequence -18 ... 1-.
- Remove bolts and carefully release camshaft housing from bonded joint.

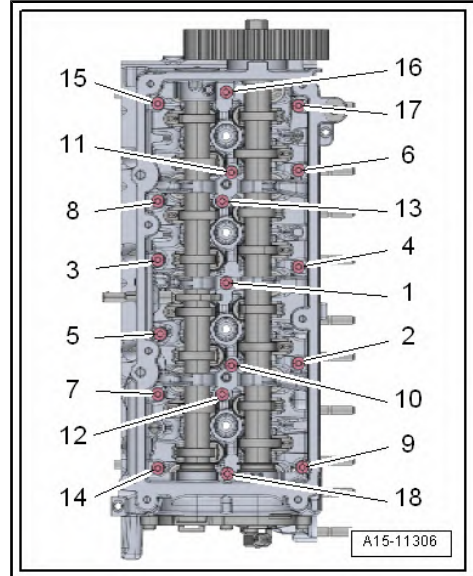

### Installation



#### Caution

*Danger of soiling lubrication system and bearings.*

- ◆ *Cover open parts of engine.*



#### WARNING

*Risk of eye injury.*

- ◆ *Use safety goggles!*

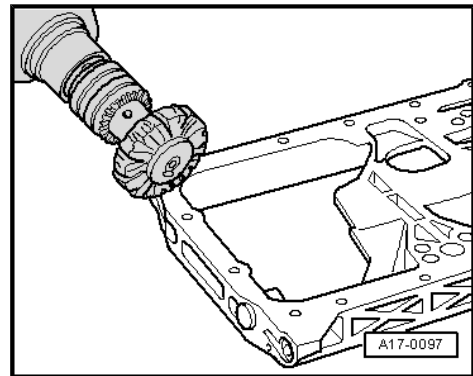

- Remove remaining sealant from cylinder head and camshaft housing using rotating plastic brush or similar.
- Clean surfaces; they must be free of oil and grease.



#### Note

*Note the use-by date of the sealant.*

- Cut off nozzle of tube at front marking (nozzle  $\varnothing$  approx. 1.5 mm).

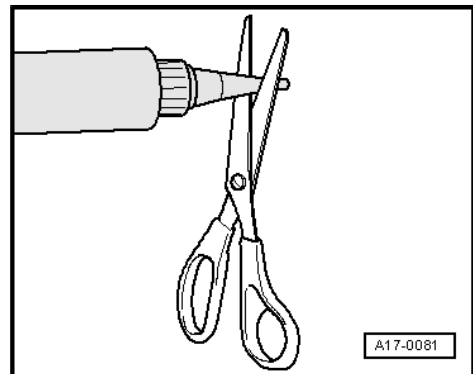



### Caution

**Make sure excess sealant does not contaminate camshaft bearings.**

- ◆ **The beads of sealant must not be thicker than specified.**

- Apply bead of sealant -arrow- onto clean sealing surfaces of cylinder head as shown in illustration.
- Width of beads of sealant: 2 mm.



### Note

- ◆ *The camshaft housing must be installed within 5 minutes after applying the sealant.*
- ◆ *After installing the camshaft housing, wait about 30 minutes for the sealant to dry.*
- Carefully fit camshaft housing on cylinder head, paying attention to dowel pins.
- Tighten camshaft housing bolts ⇒ [page 140](#) .

Remaining installation steps are the reverse of removal; note the following:

- Install emission control module ⇒ [page 390](#) .
- Fit the camshaft seal ⇒ [page 141](#) .
- Install the cover for the roller rocker fingers ⇒ [page 103](#) .
- Install coolant pipes (left-side) ⇒ [page 215](#) .
- Install notched belt (adjusting valve timing) ⇒ [page 136](#) .

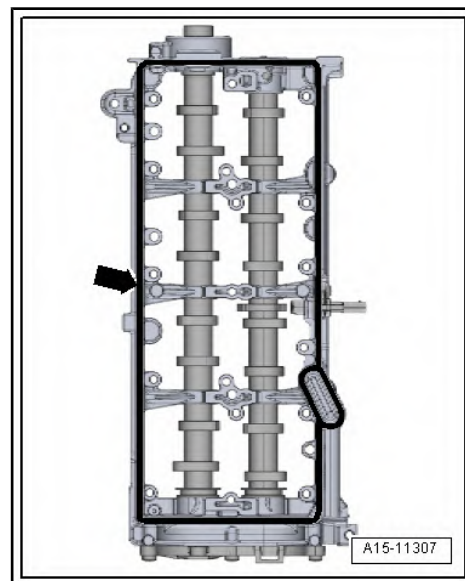

### Caution

**Risk of damage to valves and piston crowns after working on valve gear.**

- ◆ **The hydraulic tappets have to settle; wait for approx. 30 minutes after installing camshafts before starting engine.**
- ◆ **Turn the crankshaft carefully at least 2 rotations to ensure that none of the valves make contact when the starter is operated.**



### Note

- ◆ *After new components have been installed (engine/short engine, cylinder head, camshaft housing or turbocharger) the oil pressure control must be set to max. pressure for approx. 1,000 km. This will compensate for the increased friction during run-in of new components, and a better transport of wear-related particles is guaranteed. To do this, connect vehicle diagnostic and service information system, switch on ignition and select the following menu item:*
- ◆ Oil pressure for entry in the engine



## Note

Depending on the vehicle, the engine and the firmware version of the vehicle diagnostic and service information system, the specified path may vary slightly.

## Specified torques

- ◆ ⇒ [Fig. ““Camshaft housing - tightening torque and sequence””, page 140](#)
- ◆ ⇒ [“3.1 Exploded view - coolant pipes”, page 208](#)
- ◆ ⇒ [“3.2 Exploded view - high-pressure reservoir \(rail\)”, page 299](#)

## 1.7 Check compression pressure

### Special tools and workshop equipment required

- ◆ Jointed wrench - 3220-
- ◆ Compression tester - V.A.G 1763- with adapter - V.A.G 1763/8-



### Operation process

- Engine oil temperature: approx 80 °C.
- Battery voltage at least 12.5 V
- Remove engine cover. ⇒ [page 56](#)
- Unplug electrical connector on fuel pressure regulating valve - N276- -item 2-
- Briefly start engine to relieve fuel pressure in high-pressure reservoir.
- Remove all glow plugs ⇒ [page 443](#) .

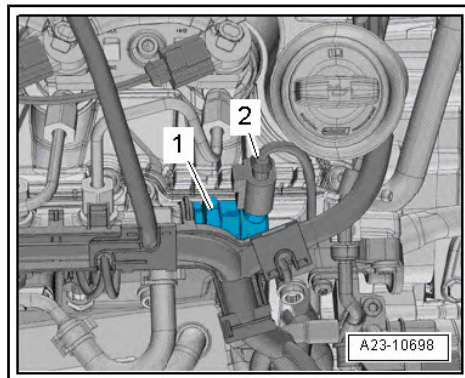

- Screw in adapter - V.A.G 1763/8- in place of corresponding glow plug and connect compression tester - V.A.G 1763- .

 **Note**

*Handling the test equipment=> instructions for use*

- Have a second mechanic operate starter until tester shows no further pressure increase.
- Repeat procedure on each cylinder.

Compression pressure	Bar
New	25.0 ... 31.0
Wear limit	19.0
Maximum difference between cylinders	5.0

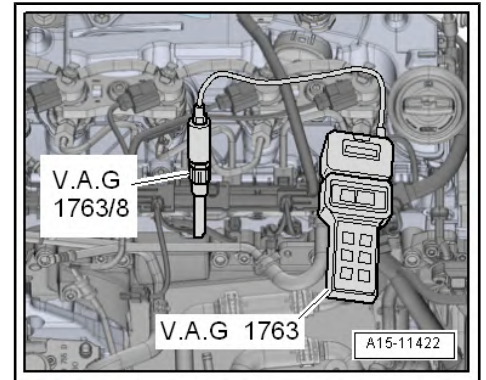

**Assembling**

The assembly is done in the reverse order; note the following:

- Since the electrical plug-in connectors were disconnected and the engine started, certain entries were recorded in the event memory of the engine management module: Call up from event memory => Vehicle diagnostic tester.

**Specified torques**

- ◆ Assembly overview: glow plug system  
 => ["1.1 Assembly overview - glow plug system", page 443](#)

## 2 Toothed belt drive

⇒ ["2.1 Exploded view - toothed belt cover", page 114](#)

⇒ ["2.2 Exploded view - toothed belt", page 115](#)

⇒ ["2.3 Removing and installing toothed belt cover", page 116](#)

⇒ ["2.4 Timing belt: removing, fitting, tensioning", page 120](#)

⇒ ["2.5 Detaching toothed belt from camshaft", page 132](#)

### 2.1 Exploded view - toothed belt cover

#### 1 - Bottom toothed belt guard

- Removing and fitting  
⇒ [page 119](#)

#### 2 - Bolt.

- With collar
- Captive in toothed belt cover (bottom)
- 12 Nm

#### 3 - Bracket/bearing/support

- for coolant lines

#### 4 - Bolt.

- 5 Nm

#### 5 - Pipe

- To pressure differential sender - G505-

#### 6 - Clip

#### 7 - Bolt.

- 5 Nm

#### 8 - Bracket/bearing/support

- for coolant lines and SCR line

#### 9 - Heat shield

#### 10 - Bolt.

- 5 Nm

#### 11 - Bracket/bearing/support

- For measuring tube

#### 12 - Toothed belt cover (top)

- Removing and fitting  
⇒ [page 116](#)

#### 13 - Bolt.

- Apply locking fluid when installing; refer to ⇒ Electronic parts catalogue
- 12 Nm

#### 14 - Rear toothed belt guard

- To remove, take out coolant pump ⇒ [page 203](#)

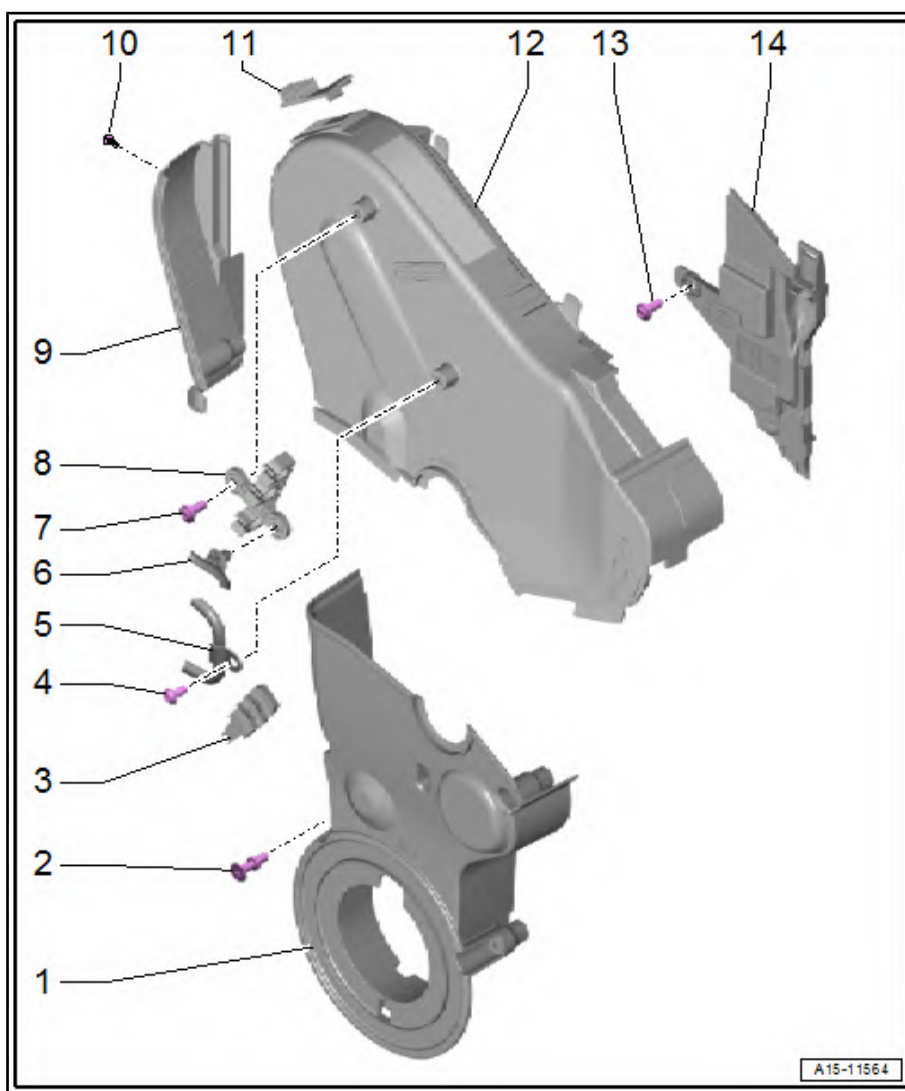

## 2.2 Exploded view - toothed belt

### 1 - Bolt.

- Renew following removal
- Loosen and tighten with retention tool - 3415-
- Do not additionally oil or grease thread and shoulder.
- 180 Nm +135° (turning further to torque angle can be performed in stages, e.g. 90° + 45°)

### 2 - Crankshaft pulley

- Contact surface between sprocket and crankshaft must be free of oil
- Fitting possible in one position only.

### 3 - Nut

- 20 Nm

### 4 - Stabiliser roller

### 5 - Nut

- Renew following removal
- 20 Nm + turn +45° further

### 6 - Tensioning roller

### 7 - Toothed belt

- Before removing, mark direction of rotation with chalk or felt-tip pen
- Check for wear
- Removal ⇒ [page 120](#)
- Installing (adjusting valve timing) ⇒ [page 125](#)

### 8 - Bolt.

- Use counterhold tool - T10172- with adapters -T10172/11- to loosen and tighten
- Do not additionally oil or grease thread and shoulder.
- 100 Nm

### 9 - Fixing screw

- 9 Nm

### 10 - Camshaft sprocket

- Contact surface between sprocket and camshaft must be free of oil

### 11 - Locating arm for camshaft

- Removing and fitting ⇒ [“1.6 Removing and installing camshaft housing”, page 107](#)

### 12 - Bolt.

- 20 Nm

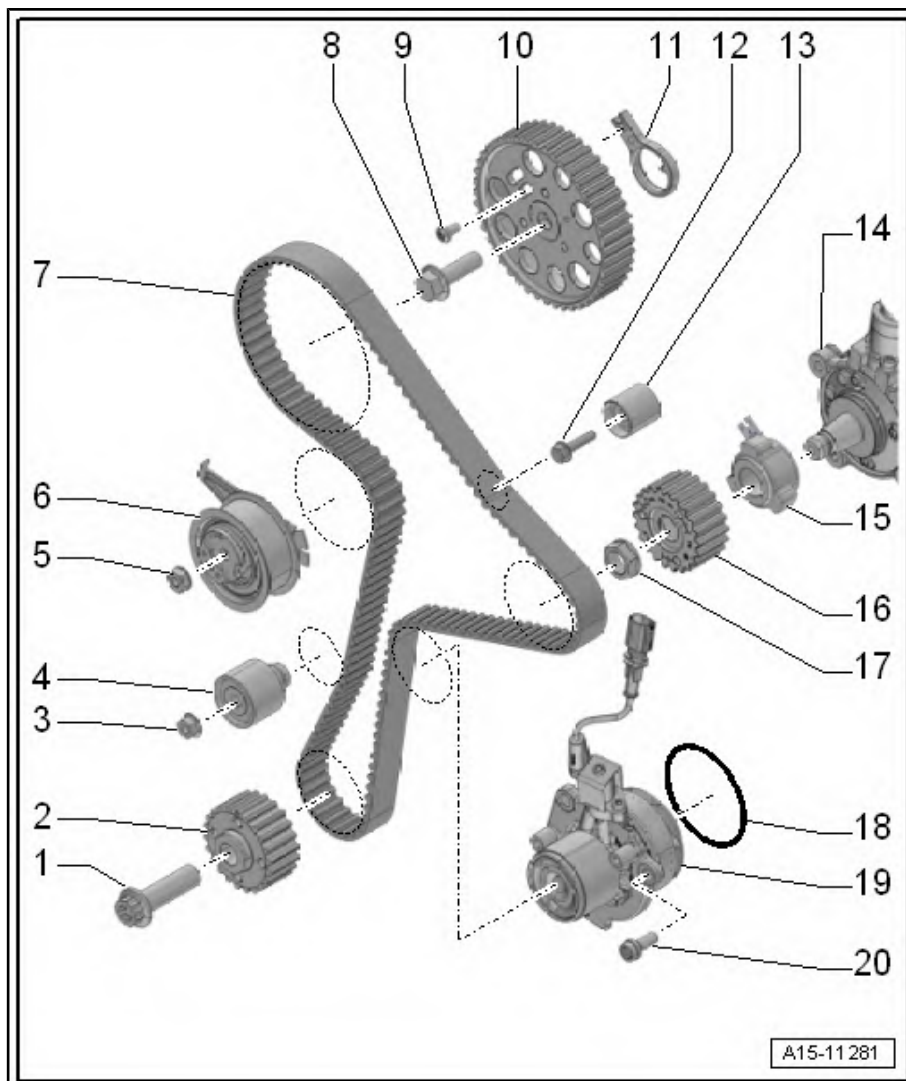

### 13 - Stabiliser roller

### 14 - High-pressure pump

- Assembly overview ⇒ [page 356](#)

### 15 - Hub for the high pressure pump

- Assembly overview ⇒ [page 356](#)
- Contact surface between hub and toothed belt sprocket must be free of oil

### 16 - High-pressure pump sprocket

- Assembly overview ⇒ [page 356](#)
- Contact surface between hub and toothed belt sprocket must be free of oil

### 17 - Nut

- Do not additionally oil or grease thread and shoulder.
- Tightening torque ⇒ [page 356](#)

### 18 - O-ring

- Renew following removal
- Lubricate with coolant

### 19 - Coolant pump

- Removing and fitting ⇒ [page 203](#)

### 20 - Bolt.

- Tightening torque ⇒ [Item 11 \(page 189\)](#)

## 2.3 Removing and installing toothed belt cover

⇒ [“2.3.1 Removing and installing toothed belt cover \(top\)”, page 116](#)

⇒ [“2.3.2 Removing and installing toothed belt cover \(bottom\)”, page 119](#)

### 2.3.1 Removing and installing toothed belt cover (top)

Special tools and workshop equipment required

- ◆ Wrench kit - T10395 A-



## Removal

- Remove engine cover. ⇒ [page 56](#)



### Caution

*Risk of damage caused by particles of dirt.*

- ◆ *Observe rules for cleanliness when working on the fuel supply system ⇒ [page 13](#).*

- Disconnect fuel lines -1, 2-; to do so, first press hose connector downwards -arrow A-, then press release tabs -arrows B-.
- Pull off hose connector, keeping release tabs depressed.
- Move clear bracket -3- with fuel hoses.
- Unscrew nut -2- and bolts -1-.
- Move fuel filter -4- clear to one side.

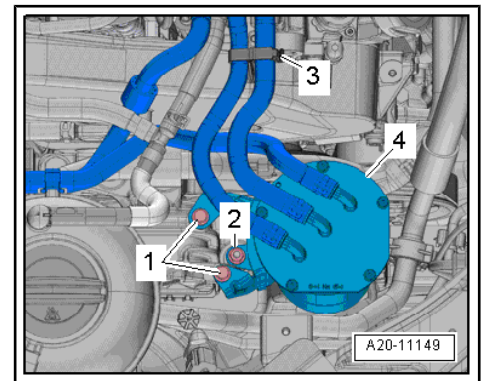
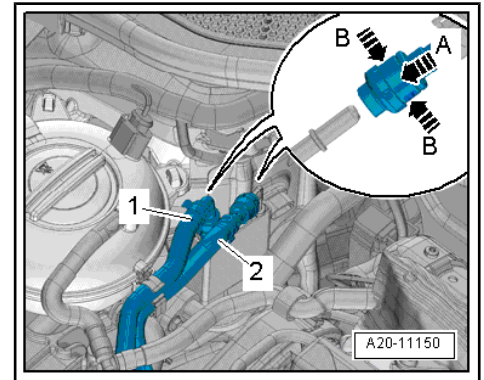

- Screw out the exhaust gas temperature sender 3 - G495- -B- with a tool from the set of wrenches - T10395 A- .
- Release clip -A-, disconnect coolant hose and push to one side.

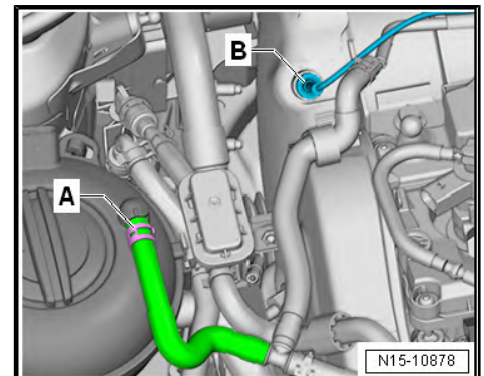

### LHD vehicles with pressure differential sender - G505- :

- Open heat insulation sleeve -1-.
- Unplug the electrical connector -4-.
- Remove bolt -3- and detach pressure differential sender - G505- from bracket.



### Note

*Disregard -item 2-.*

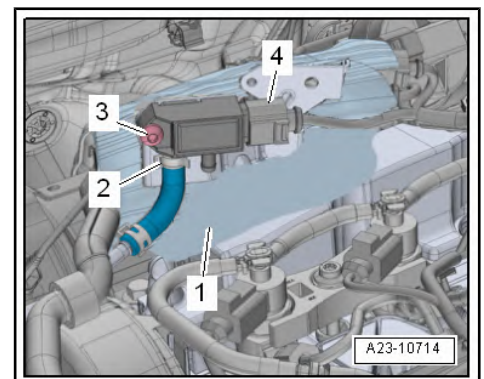

- Remove bolt -arrow-, move pipe clear and push to side.
- Release clip -A-, disconnect hose, unclip pipe -B- and detach together with pressure differential sender - G505- .

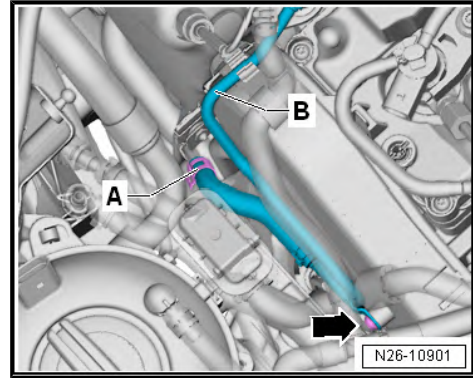

**Vehicles with pressure differential sender - G505- and pressure sensor 1 for exhaust - G450-**

- Open heat insulation sleeve -1-.
- Unplug electrical connector -3- and move wiring clear.
- Unscrew the bolt -2-.
- Unplug the electrical connector -4-.

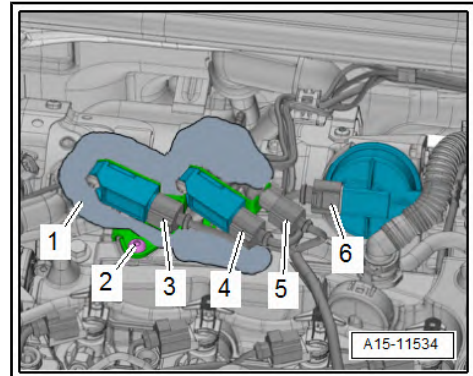

- Disconnect vacuum hose -arrow- and lay it to one side.

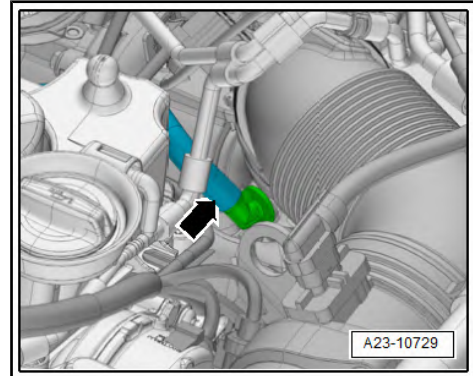

- Unscrew the bolt -3-.
- Undo the hose clips -1- and remove the hoses.
- Expose lines -2-.

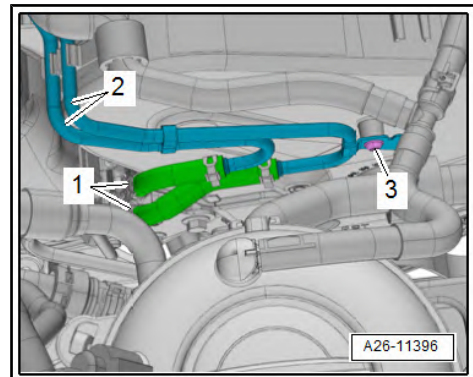

### All vehicles (continued):

- Release catches -arrows-, disengage toothed belt cover (top) -1- and detach.

### Installation

Installation is carried out in the reverse order; note the following:

- Install engine cover panel ⇒ [page 56](#) .
- Bleeding the fuel system ⇒ [page 293](#) .

### Specified torques

- ◆ ⇒ [“3.1 Assembly overview - exhaust gas temperature regulation”, page 411](#)
- ◆ Assembly overview - fuel filter ⇒ Rep. gr. 20 ; Fuel filter; Assembly overview - fuel filter .
- ◆ Control pipe from pressure differential sender to toothed belt cover ⇒ [“2.1 Exploded view - toothed belt cover”, page 114](#)

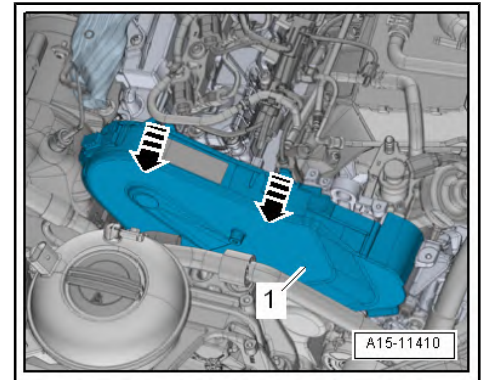

## 2.3.2 Removing and installing toothed belt cover (bottom)

### Removal



#### Note

- ◆ *To simplify the production process during manufacturing, the toothed belt cover (bottom) has a guide lug which engages in the sealing flange. This guide lug must be irreparably damaged in order to remove the toothed belt cover (bottom), even with the engine support installed.*
- ◆ *Note different versions.*
- Remove front right-hand spoiler wheel housing shell ⇒ General body repairs, exterior; Rep. gr. 66 ; Wheel housing shell; Assembly overview - Front wheel housing shell .
- Remove vibration damper ⇒ [page 61](#) .



#### Caution

**Take great care when performing the following step. If the toothed belt is damaged, damage to the engine may result.**

- For old version of toothed belt cover, drill a hole according to following dimensions:
- ◆ Dimension -a-: 10 mm
- ◆  $\varnothing$  8 mm
- Insert screwdriver through hole and press back guide lug of toothed belt cover to break it off.

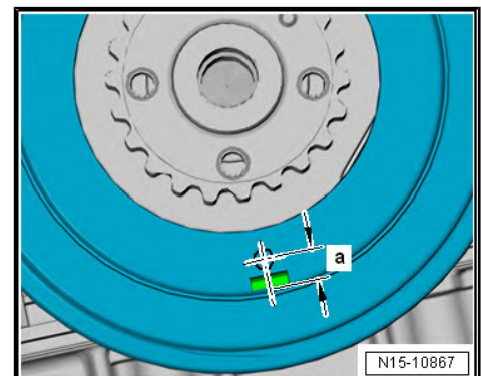

- For new version of toothed belt cover, insert screwdriver into slot in guide lug.
- Break off guide lug by turning screwdriver in direction of -arrow-.

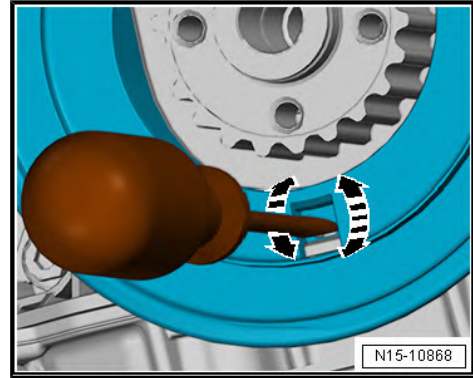

- Remove bolts -arrows-.
- Remove lower toothed belt guard -1-.

### Installation

Installation is carried out in the reverse order; note the following:



#### Note

*If a new toothed belt guard is installed, the guide lug -arrow- must be cut off prior to installing.*

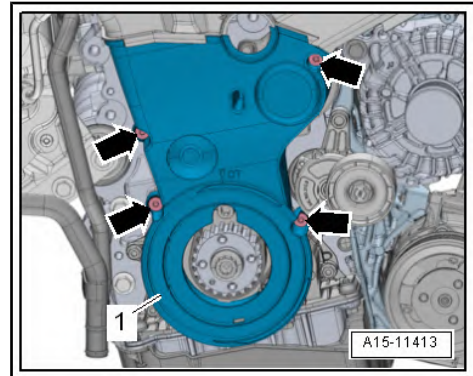

### Guide lug on toothed belt guard

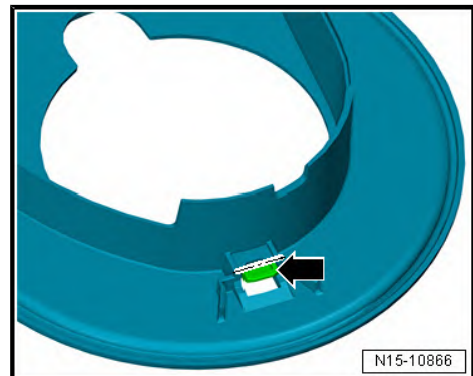

- Fit toothed belt cover (note position of dowel pin -arrow-).
- Tighten the bolts for the toothed belt cover.



#### Note

*Mount the toothed belt guard -1- noting the dowel pin -arrow- in the process.*

- Fit the vibration damper ⇒ [page 61](#) .

### Specified torques

- ♦ ⇒ ["2.1 Exploded view - toothed belt cover", page 114](#)

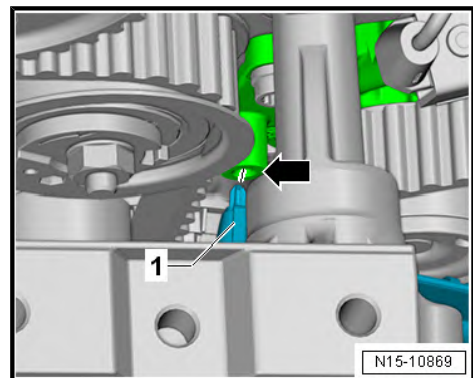

## 2.4 Timing belt: removing, fitting, tensioning

Special tools and workshop equipment required

- ◆ Diesel injection pump locking pin - 3359-

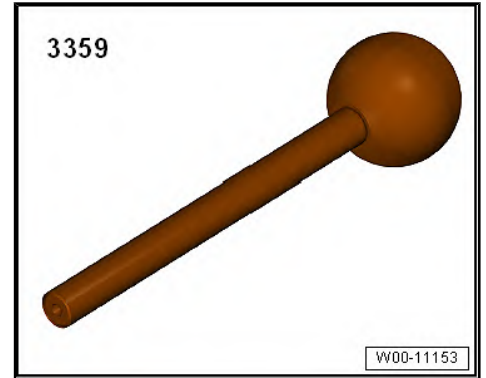

- ◆ retention tool - T10051-

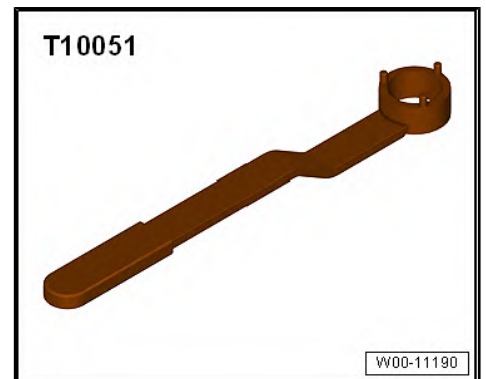

- ◆ Counterhold tool - T10172- with adapters -T10172/11-

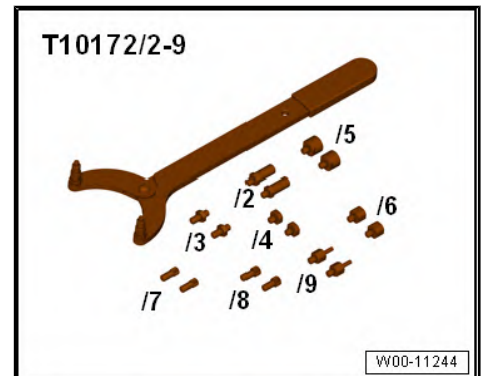

- ◆ Special wrench, long reach - T10264-

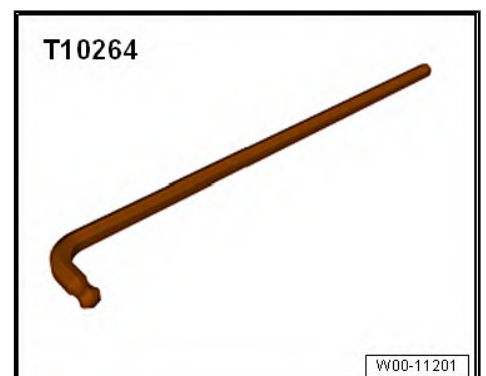

- ◆ Dowel pin - T10265-

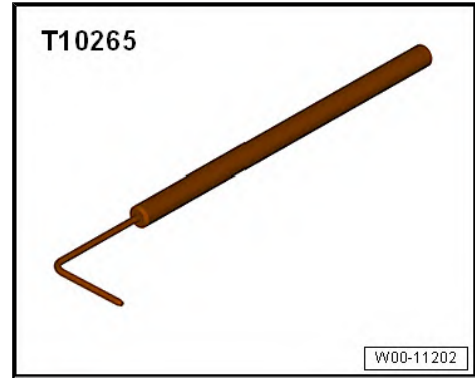

- ◆ Dowel pin -T10492-



- ◆ Crankshaft stop -T10490-

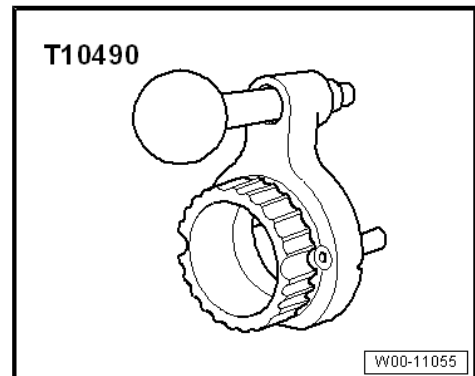

- ◆ Sealing cap set for engine - VAS 6122-

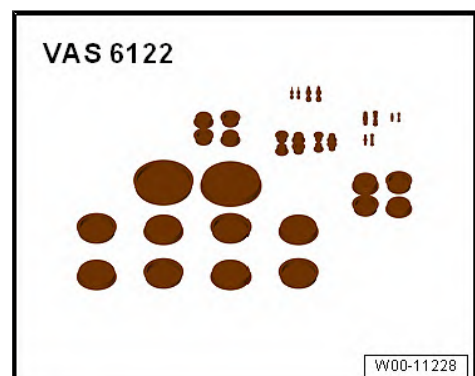

## Removal

- Remove engine cover. ⇒ [page 56](#)



**Caution**

*Risk of destruction due to toothed belt jumping exists.*

◆ *Turn crankshaft only in direction of engine rotation.*

- Disconnect fuel lines -1, 2-; to do so, first press hose connector downwards -arrow A-, then press release tabs -arrows B-.

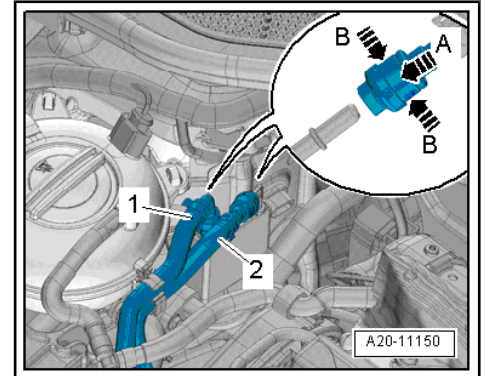

- Remove the bracket -2- with fuel hoses.
- Unplug the electrical connector -1-.
- Loosen the hose clip -3- and remove the coolant hose; when doing this use the engine bung set - VAS 6122- .
- Open the catch mechanisms with a screwdriver -Arrow-.

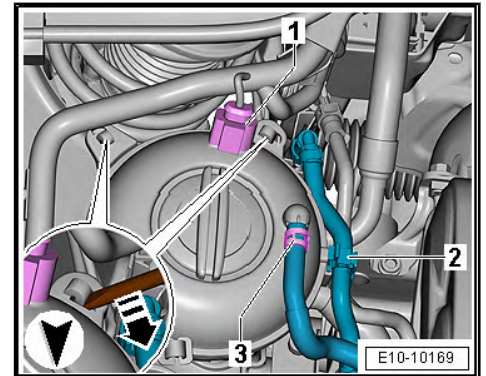

- Move clear bracket -3- with fuel hoses.
- Unscrew nut -2- and bolts -1-.
- Place the fuel filter -4- and coolant expansion tank to one side.
- Remove engine support => [page 63](#) .
- Remove toothed belt cover (bottom section) => [page 119](#) .

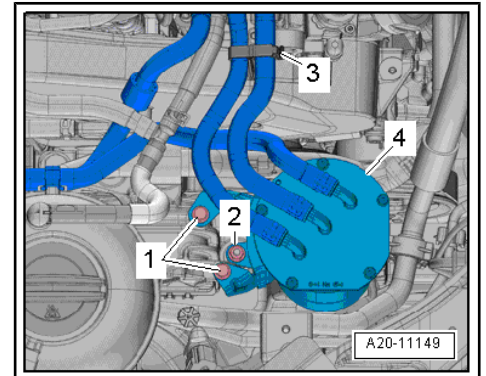

- Unscrew bolts -2- and -3- from the pendulum support.



**Caution**

*Irreparable damage can be caused if the toothed belt slips.*

◆ *Turn crankshaft only in direction of engine rotation.*

- Turn crankshaft by the bolt for the toothed belt wheel until the crankshaft toothed belt pulley is positioned at "TDC".

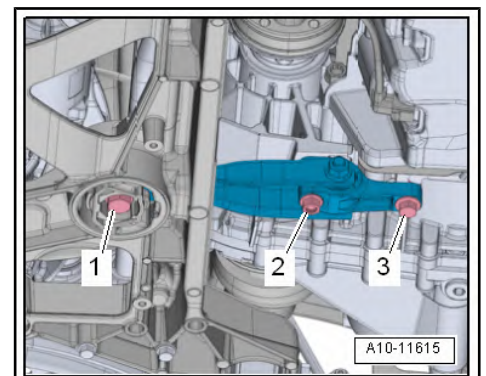

- Lock camshaft hub with diesel injection pump locking pin - 3359- ; to do so, insert locking pin into fork on locating arm -2- and into hole -1- behind it in cylinder head.

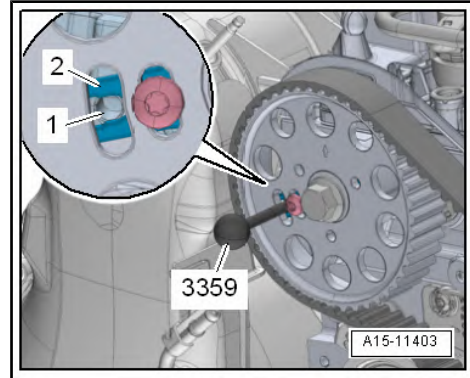

- Loosen locking bolt -1- in camshaft sprocket one half turn, but do not remove.

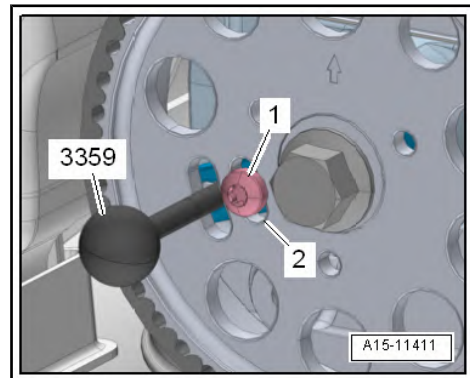

- Lock crankshaft sprocket in position with crankshaft stop - T10490- .
- Pins of crankshaft stop -T10490- must engage in threaded holes of toothed belt sprocket.
- The dowel pin of the crankshaft stop -T10490- must engage in hole on sealing flange.

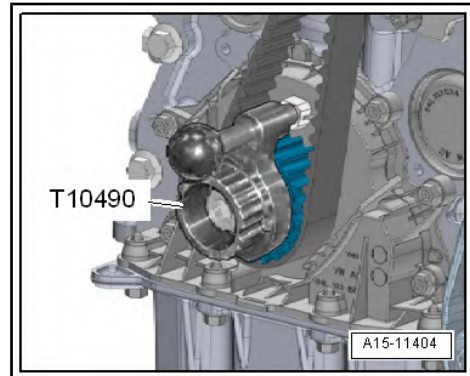

**Caution**

*It is essential that the torque for loosening and tightening the central bolts on camshaft and high-pressure pump is not transferred to the respective dowel pin. Otherwise the »actuating arms« may become damaged even if a counter-hold tool is used. These defects may not be noticed and may result in damage to the engine. Therefore, pull out dowel pin for loosening and tightening the central bolt and reinsert afterwards if necessary!*

- Pull the dowel pin and loosen the camshaft bolt. To release fully, insert the dowel pin again.
- Slacken bolt -arrow- for camshaft sprocket using counterhold tool - T10172- with adapters -T10172/11- .

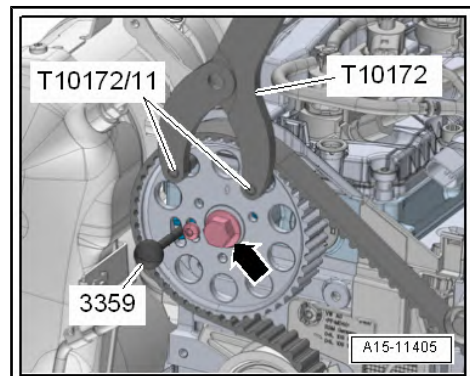

- Lock hub of high-pressure pump in position with locking pin - T10492- ; to do so, insert locking pin into fork -2- on hub and into hole -1- behind it in bracket for ancillaries.
- Pull the dowel pin and loosen the nut for high-pressure pump toothed belt pulley. To release fully, insert the dowel pin again.

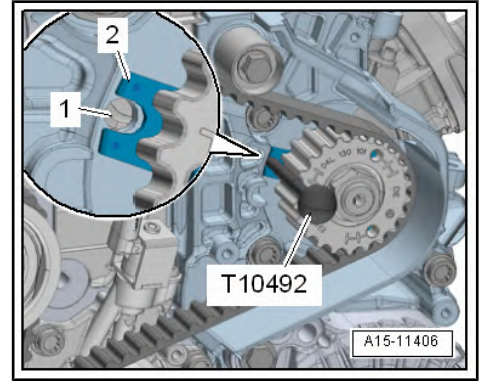

- Slacken the nut -arrow- for toothed belt sprocket of high-pressure pump approx. 90° using counterhold tool - T10051- .

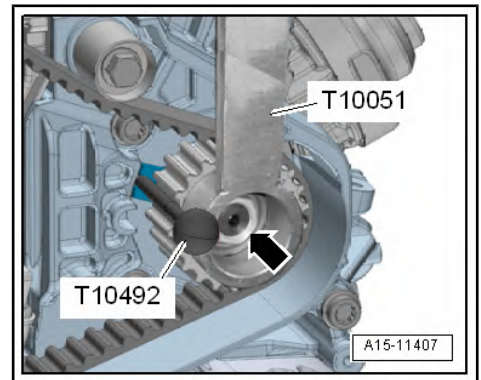

- Loosen nut -1- for tensioning roller.
- Turn eccentric adjuster of tensioning roller with special wrench, long reach - T10264- anti-clockwise -arrow- until tensioning roller can be secured with locking tool - T10265- .

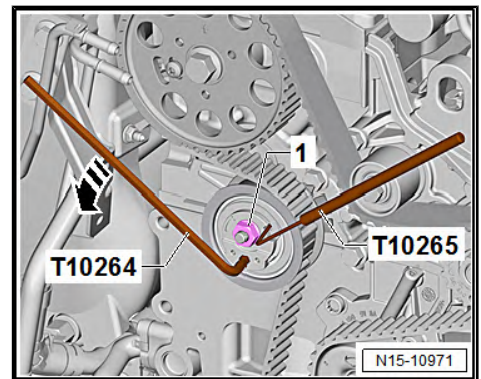

- Turn belt tensioner eccentric clockwise -arrow- to stop using special wrench, long reach - T10264- .
- Hand-tighten nut -1-.
- Before removing, mark direction of rotation of toothed belt with chalk or felt-tip pen for re-installation.
- Remove toothed belt first from coolant pump and then from remaining toothed pulleys.

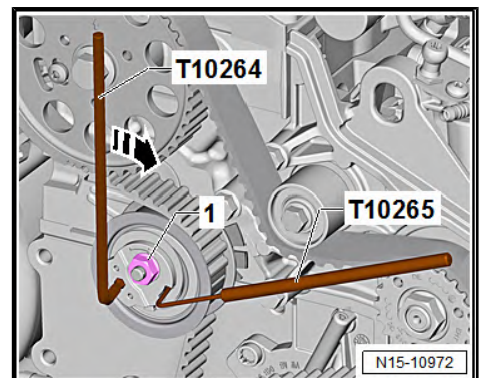

**Installing (adjusting the valve timing)**

 **Note**

The installed tensioning rollers -A and B- differ from each other. The adjustment jig -1- is the distinguishing feature. Tensioning roller -A- must not be locked with locking tool - T10265- . Instead the angle driver 8mm - T10409- must be used for tensioning. Apart from that the procedure is identical.

 **Note**

Perform adjustments on toothed belt only when engine is cold.



**Caution**

Avoid damage to valves and piston crowns.

- ◆ The crankshaft must not be at "TDC" at any cylinder when the camshaft is turned.

Requirements:

- Tensioning roller is locked with locking tool - T10265- and secured at right stop with nut -1-.
- Metal lug -arrow- of tensioning roller must engage in cast recess on cylinder head.

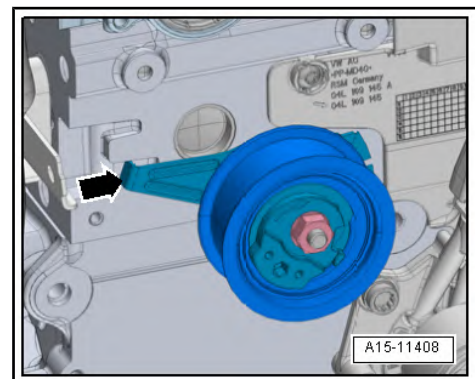
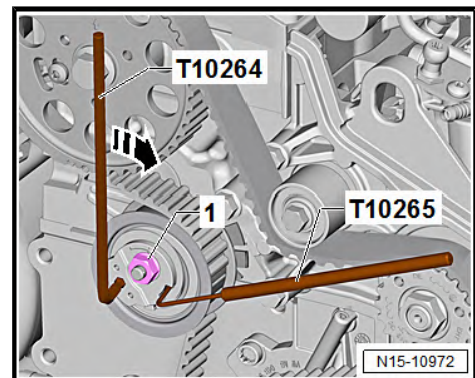
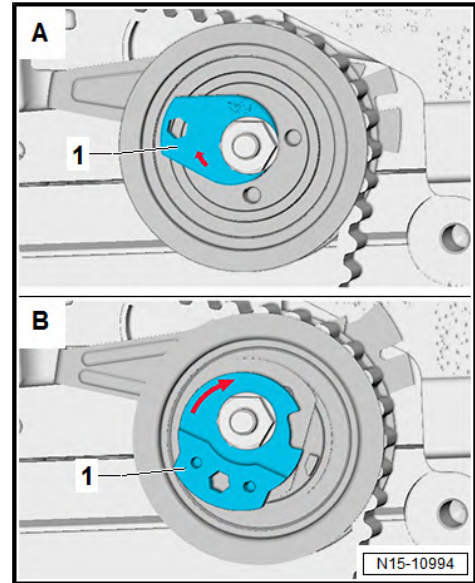

- Camshaft hub locked with diesel injection pump locking pin - 3359- .
- Bolt fitted but not tightened.
- The gear pinion of the camshaft must be turned and should not be pivoted any more.

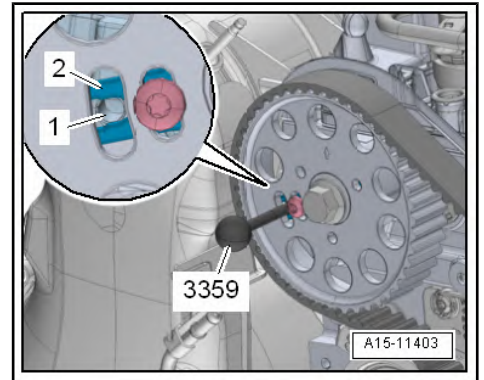

- Locking bolt -1- in locating arm loosened one half turn, positioned in centre of elongated hole -2-.

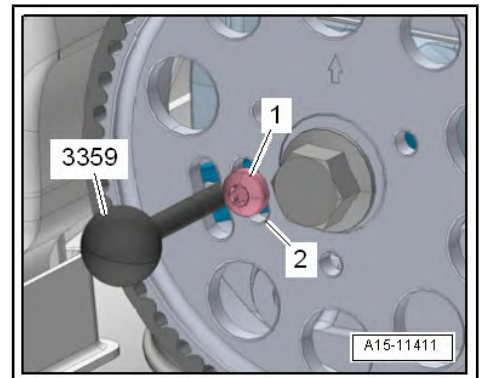

- Crankshaft is locked in position with crankshaft stop -T10490- .

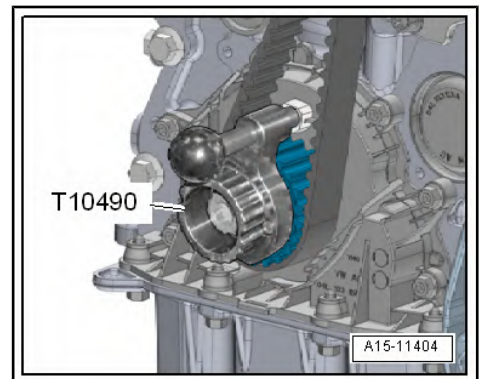

- High-pressure pump locked with the dowel pin -T10492- .
- Nut fitted but not tightened.
- The gear pinion of the high pressure pump must be turned and should not be pivoted any more.

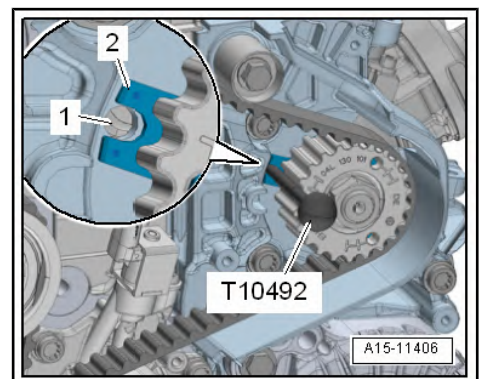

- Turn the camshaft sprocket and high-pressure pump sprocket in their elongated holes clockwise as far as the stop.
- Install toothed belt in the specified sequence:
  - 1 - Crankshaft pulley
  - 2 - Tensioning roller
  - 3 - Camshaft sprocket
  - 4 - High-pressure pump sprocket
  - 5 - Coolant pump toothed belt pulley

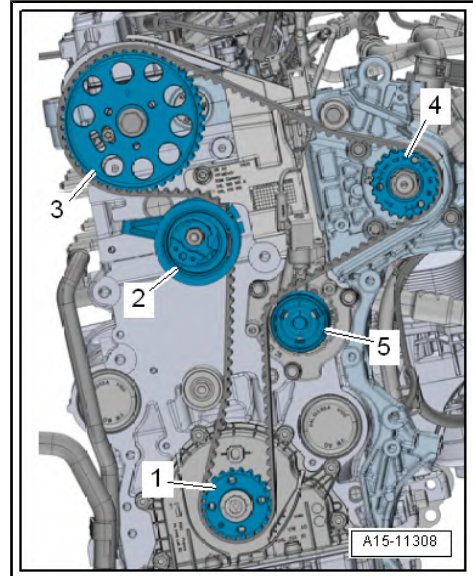

- Loosen nut -1- for tensioning roller and detach locking tool - T10265- .



**Note**

- ◆ *Metal lug of tensioning roller must remain engaged in cast recess on cylinder head.*
- ◆ *-Arrow- can be disregarded.*

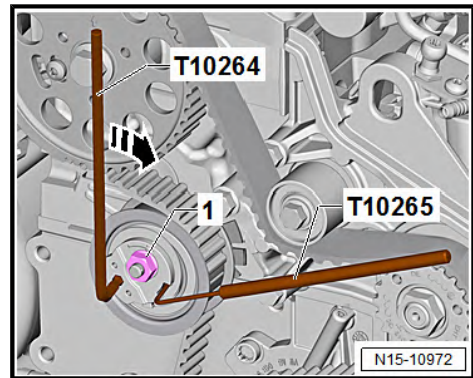

**Caution**

*The locking bolt must not lie against upper stop of elongated hole after toothed belt has been tensioned.*

- Check whether the securing bolt -1- is still between the centre of the elongated bore and the lower stop -2-. If necessary correct the position of the toothed belt pulley by turning it clockwise by one tooth and then fitting the toothed belt again.

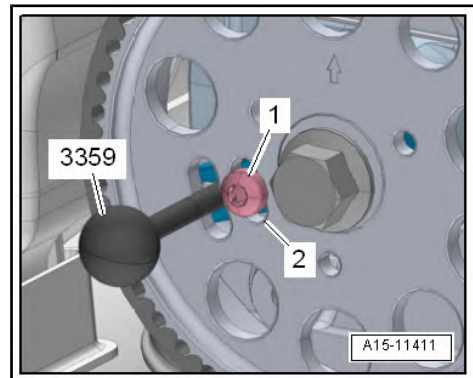

- Using angle driver - T10264- or angle driver 8mm - T10409- , carefully turn tensioning roller eccentric clockwise -arrow- until indicator -2- is in the middle of gap in base plate.
- Nut -1- must not turn.
- Hold tensioning roller in this position and tighten nut.

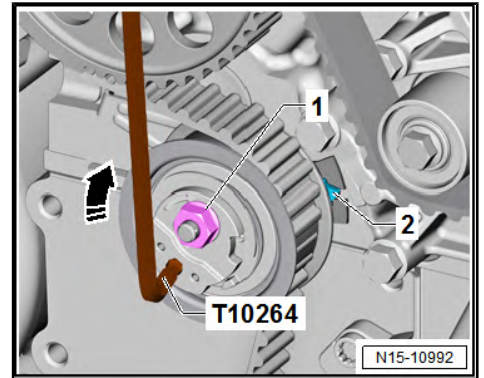

- Position counterhold tool - T10172- with adapters -T10172/11- on camshaft sprocket as shown in illustration.
- Apply force to counterhold tool in anti-clockwise direction -arrow- and maintain tension.
- In this position, tighten bolt -1- for camshaft pulley and nut -2- for high-pressure pump pulley to 20 Nm.

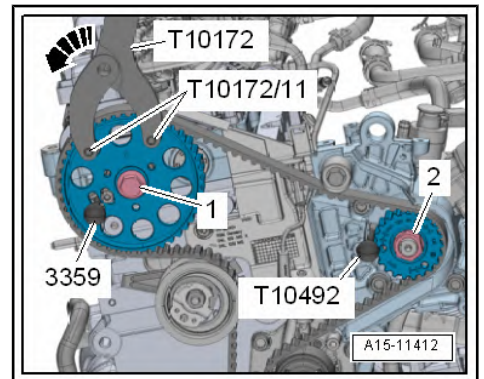

 **Note**

*The high-pressure pump pulley can only be turned to a limited extent. It is therefore essential to ensure that the toothed belt pulley has not been turned to the »limit« after tensioning.*

- Check that the marking on the crankshaft sprocket of the high-pressure pump is not aligned with the pin. If necessary correct the position of the affected high-pressure pump sprocket by turning it clockwise by one tooth and then fitting the toothed belt again.
- Remove locking pins -3359- , -T10492- and crankshaft stop - T10490- and check valve timing => [page 129](#) .

**Check valve timing:**

 **Caution**

*Avoid irreparable engine damage caused by the toothed belt's jumping.*

◆ *Turn crankshaft only in direction of engine rotation.*

- Turn crankshaft two rotations in direction of engine rotation by turning bolt for crankshaft sprocket until crankshaft is just before "TDC".

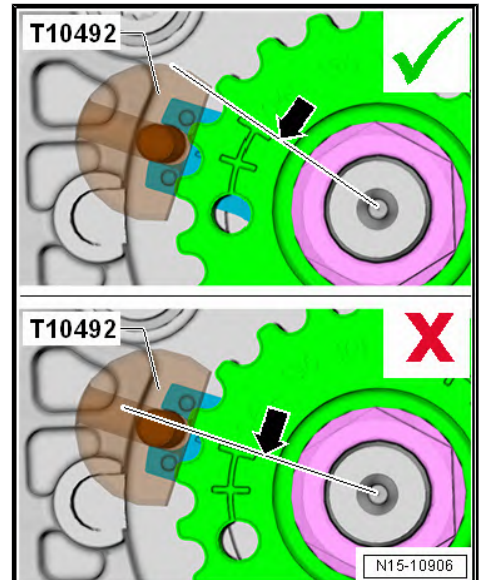

- Fit crankshaft stop -T10490- on crankshaft sprocket again.
- Turn crankshaft in engine direction of rotation until crankshaft stop pin -arrow- engages in sealing flange whilst turning.



**Caution**

*The crankshaft must be exactly in "TDC" position to ensure accurate valve timing adjustment.*

- ◆ *If you go past "DTC": turn crankshaft a further two turns until it is just before "DTC" again. Then turn further in the same direction and lock crankshaft with crankshaft stop - T10490- .*

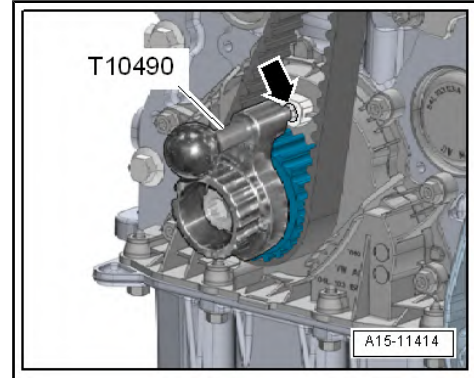

- It should now be possible to lock camshaft hub with diesel injection pump locking pin - 3359- .

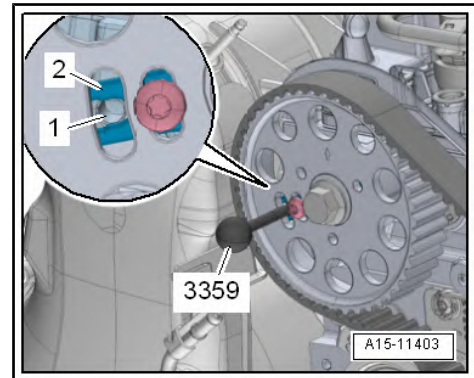

- It is very difficult to find the securing position of the high-pressure pump hub again. However, a slight deviation -arrow- does not influence engine operation.

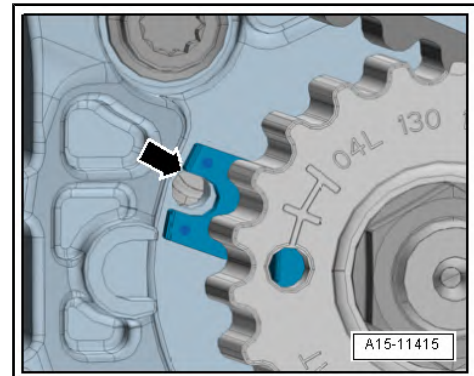

- Pointer -2- on tensioner roller must be centred between tabs -1- and -3- on base plate.

**Note**

*The maximum permissible sideways deviation from the specified position is 5 mm.*

If requirements are met, continue with procedure after adjusting valve timing correctly as described below ⇒ [page 131](#) .

Re-adjust valve timing if requirements are not met ⇒ [page 131](#) .

**Re-adjusting the valve timing:**

- If camshaft hub cannot be locked, withdraw crankshaft stop -T10490- until pin is clear of bore.
- Turn crankshaft in opposite direction of engine rotation slightly past “TDC”.
- Now slowly the crankshaft in the direction of the engine rotation till the hub of the camshaft can be locked.
- Loosen bolts for camshaft sprocket after locking hub.

A - If pin of crankshaft stop -T10490- is on left side of bore:

- Turn crankshaft in engine direction of rotation until crankshaft stop pin -arrow- engages in sealing flange whilst turning.
- Tighten camshaft sprocket bolts to 20 Nm.

B - If pin of crankshaft stop -T10490- is on right side of bore:

- Turn crankshaft slightly in opposite direction to engine rotation.
- Turn crankshaft in direction of engine rotation again until pin of crankshaft stop engages in sealing flange as crankshaft rotates.
- Tighten camshaft sprocket bolts to 20 Nm.

**Procedure after adjusting valve timing correctly:**

- Remove diesel injection pump dowel pin - 3359- and crankshaft stop -T10490- .
- Turn crankshaft two rotations in direction of engine rotation by turning bolt for crankshaft sprocket until crankshaft is just before “TDC”.
- Check the valve timing once more ⇒ [page 129](#) .

**Caution**

*It is essential that the torque for loosening and tightening the central bolts on camshaft and high-pressure pump is not transferred to the respective dowel pin. Otherwise the »actuating arms« may become damaged even if a counter-hold tool is used. These defects may not be noticed and may result in damage to the engine. Therefore, pull out dowel pin for loosening and tightening the central bolt and reinsert afterwards if necessary!*

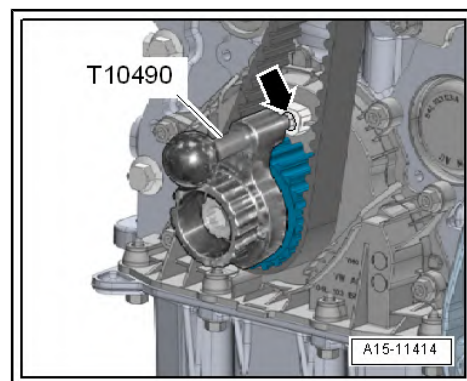
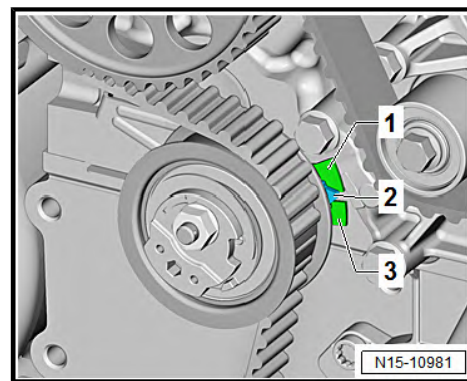

- If camshaft hub can now be locked, tighten camshaft sprocket bolt -1- to final torque using counterhold tool - T10172- with adapters -T10172/11- ⇒ [Item 8 \(page 115\)](#) .
- Tighten bolts -2- for high-pressure pump sprocket to final torque ⇒ [page 356](#) ; to do so, use counterhold tool - T10051- .
- Check the valve timing once more ⇒ [page 129](#) .

### Assembling

Further installation is carried out in the reverse order; note the following:



### Note

- ◆ *Renew seals*
- ◆ *Secure all hose connections with the hose clips corresponding to original equipment ⇒ [Electronic parts catalogue](#) .*
- Tighten locking bolt -1-.
- Install toothed belt cover (bottom) ⇒ [page 119](#) .
- Mount the engine support foot ⇒ [page 63](#) .

### Specified torques

- ◆ ⇒ ["2.1 Exploded view - toothed belt cover", page 114](#)
- ◆ ⇒ ["2.2 Exploded view - toothed belt", page 115](#)

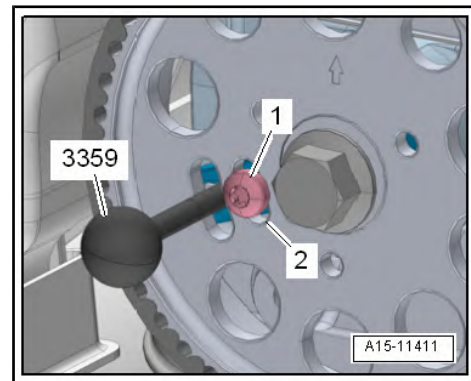
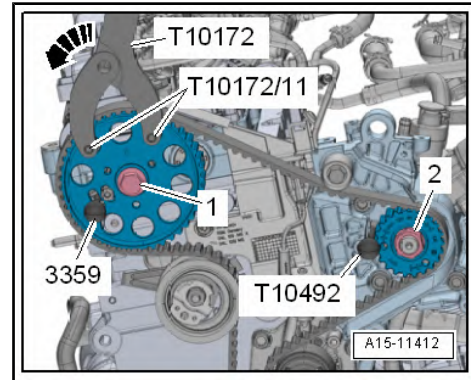

## 2.5 Detaching toothed belt from camshaft

### Special tools and workshop equipment required

- ◆ Diesel injection pump locking pin - 3359-



- ◆ retention tool - T10051-

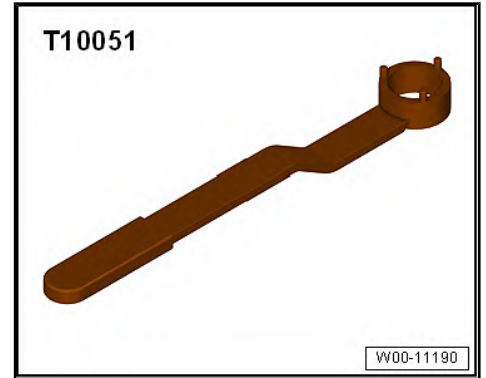

- ◆ Counterhold tool - T10172- with adapters -T10172/11-

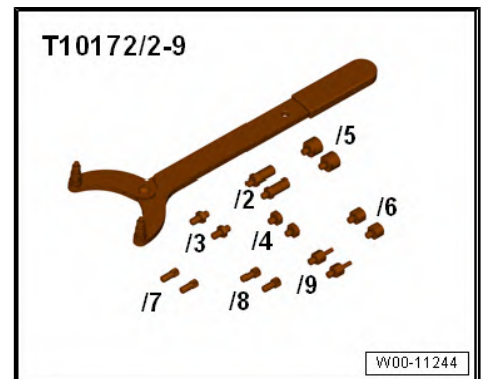

- ◆ Special wrench, long reach - T10264-



- ◆ Dowel pin - T10265-



◆ Dowel pin -T10492-



◆ Crankshaft stop -T10490-

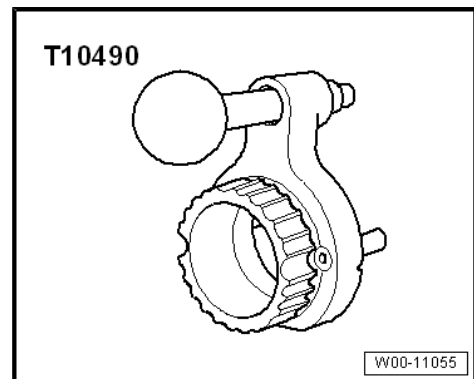

**Removal**

- Remove toothed belt cover (top) ⇒ [page 116](#) .
- Remove vibration damper ⇒ [page 61](#) .



**Caution**

*Irreparable damage can be caused if the toothed belt slips.*

- ◆ *Turn crankshaft only in direction of engine rotation.*

- Turn crankshaft by the bolt for the toothed belt wheel until the crankshaft toothed belt pulley is positioned at "TDC".
- Lock camshaft hub with diesel injection pump locking pin - 3359- ; to do so, insert locking pin into fork on locating arm -2- and into hole -1- behind it in cylinder head.

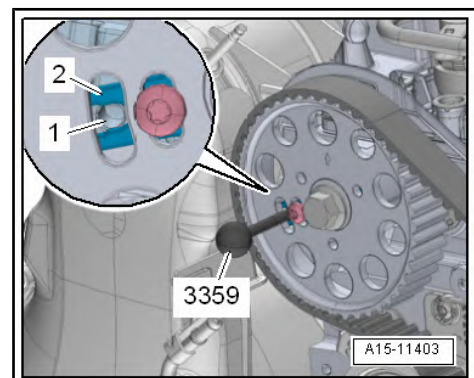

- Loosen locking bolt -1- in camshaft sprocket one half turn, but do not remove.

 **Note**

*Disregard -item 2-.*

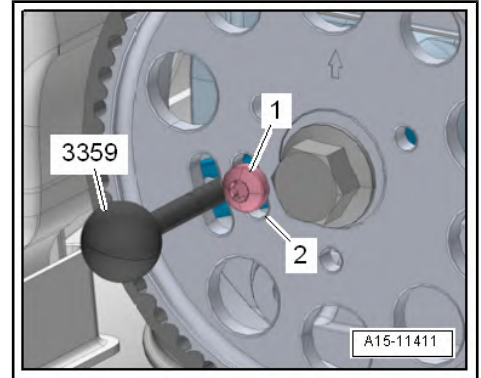

- Lock crankshaft sprocket in position with crankshaft stop - T10490- .
- Pins of crankshaft stop -T10490- must engage in threaded holes of toothed belt sprocket.
- The dowel pin of the crankshaft stop -T10490- must engage in hole on sealing flange.

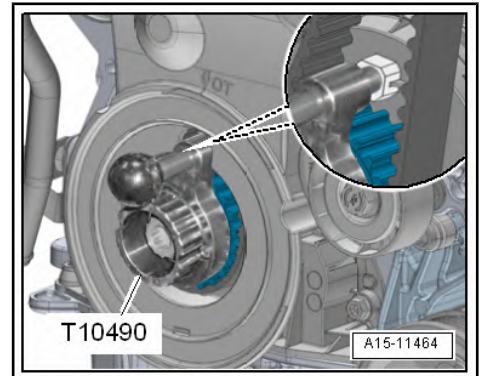

**Caution**

*It is essential that the torque for loosening and tightening the central bolts on camshaft and high-pressure pump is not transferred to the respective dowel pin. Otherwise the »actuating arms« may become damaged even if a counter-hold tool is used. These defects may not be noticed and may result in damage to the engine. Therefore, pull out dowel pin for loosening and tightening the central bolt and reinsert afterwards if necessary!*

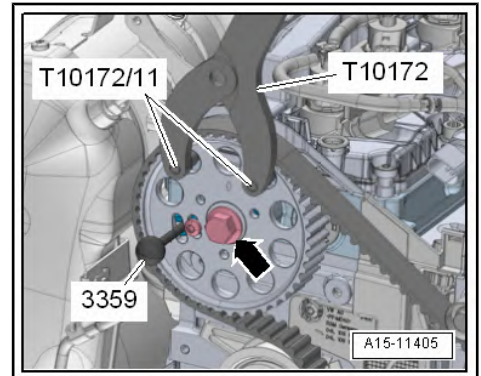

- Slacken bolt -arrow- for camshaft sprocket using counterhold tool - T10172- with adapters -T10172/11- .
- Lock hub of high-pressure pump in position with locking pin - T10492- ; to do so, insert locking pin into fork -2- on hub and into hole -1- behind it in bracket for ancillaries.

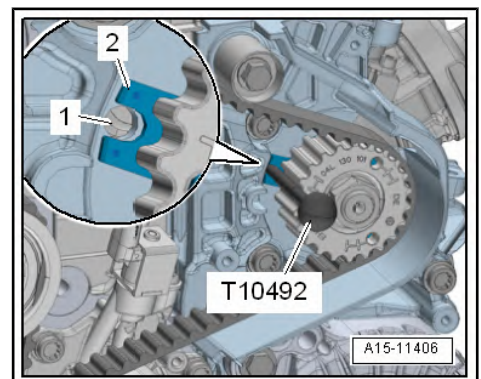

- Slacken the nut -arrow- for toothed belt sprocket of high-pressure pump approx. 90° using counterhold tool - T10051- .

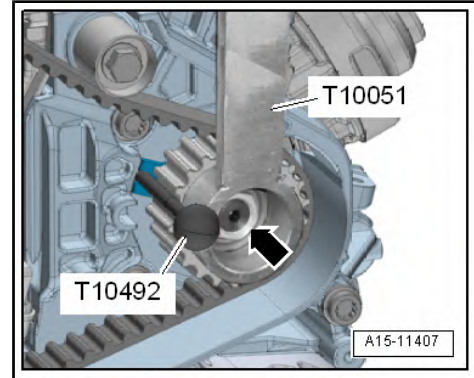

- Loosen nut -1- for tensioning roller.
- Turn eccentric adjuster of tensioning roller with special wrench, long reach - T10264- anti-clockwise -arrow- until tensioning roller can be secured with locking tool - T10265- .

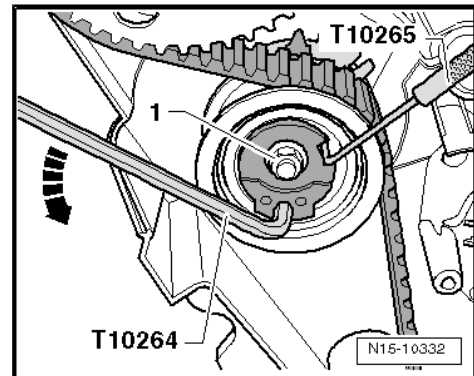

- Then use special wrench, long reach - T10264- to turn eccentric adjuster of tensioning roller clockwise -arrow- as far as stop and tighten nut -1- by hand.
- Take notched belt off camshaft sprocket.

Installing (adjusting valve timing) ⇒ [page 125](#)

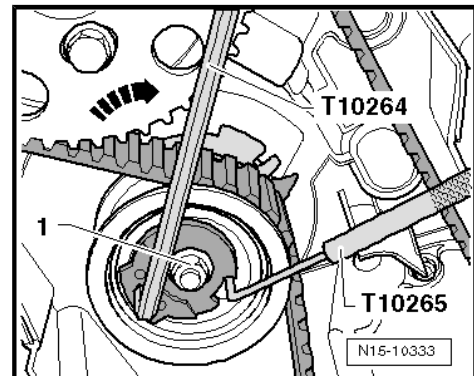

### 3 Valve gear

- ⇒ [“3.1 Assembly overview - valve gear”, page 137](#)
- ⇒ [“3.2 Measuring axial play of camshaft”, page 140](#)
- ⇒ [“3.3 Removing and installing camshaft oil seal”, page 141](#)
- ⇒ [“3.4 Removing and installing camshaft adjuster”, page 143](#)
- ⇒ [“3.5 Valve 1 for variable distribution N205 : removing and fitting”, page 148](#)
- ⇒ [“3.6 Checking hydraulic valve compensation elements”, page 148](#)
- ⇒ [“3.7 Removing and installing valve stem seals”, page 149](#)

#### 3.1 Assembly overview - valve gear



##### Caution

*Risk of damage to valves and piston crowns after working on valve gear.*

- ◆ *The hydraulic tappets have to settle; wait for approx. 30 minutes after installing camshafts before starting engine.*
- ◆ *Turn the crankshaft carefully at least 2 rotations to ensure that none of the valves make contact when the starter is operated.*

**1 - Bolt.**

- Tightening torque  
⇒ [page 443](#)

**2 - Hall sensor - G40-**

- Assembly overview  
⇒ [page 443](#)

**3 - O-ring**

- Renew following removal

**4 - Sealing plug**

- Renew following removal
- Removal: With the camshaft housing fitted, use an awl to prick one side of the cover and lift it off.
- Installing: Drive in without sealant until flush using suitable thrust piece, e.g. carrier - 3390-

**5 - Camshaft oil seal**

- Must be renewed if removed ⇒ [page 141](#) ,

**6 - Camshaft housing**

- With integrated camshafts
- Removing and fitting  
⇒ "1.6 Removing and installing camshaft housing", [page 107](#)

**7 - Bolt.**

- Renew following removal
- Sequence when loosening ⇒ [page 110](#) .
- Tightening torque and sequence ⇒ [page 140](#) .

**8 - Oil seal**

- Renew following removal

**9 - Cover**
**10 - Bolt.**

- 8 Nm

**11 - Bolt.**

- Only for vehicles with engine classification code CRLB, CRMB, CUNA
- 8 Nm

**12 - Valve 1 for variable distribution - N205-**

- Depending on version, not installed in all vehicles
- Removing and fitting ⇒ [page 148](#)

**13 - Oil seal**

- Depending on version, not installed in all vehicles
- Renew following removal

**14 - Bolt.**

- Depending on version, not installed in all vehicles

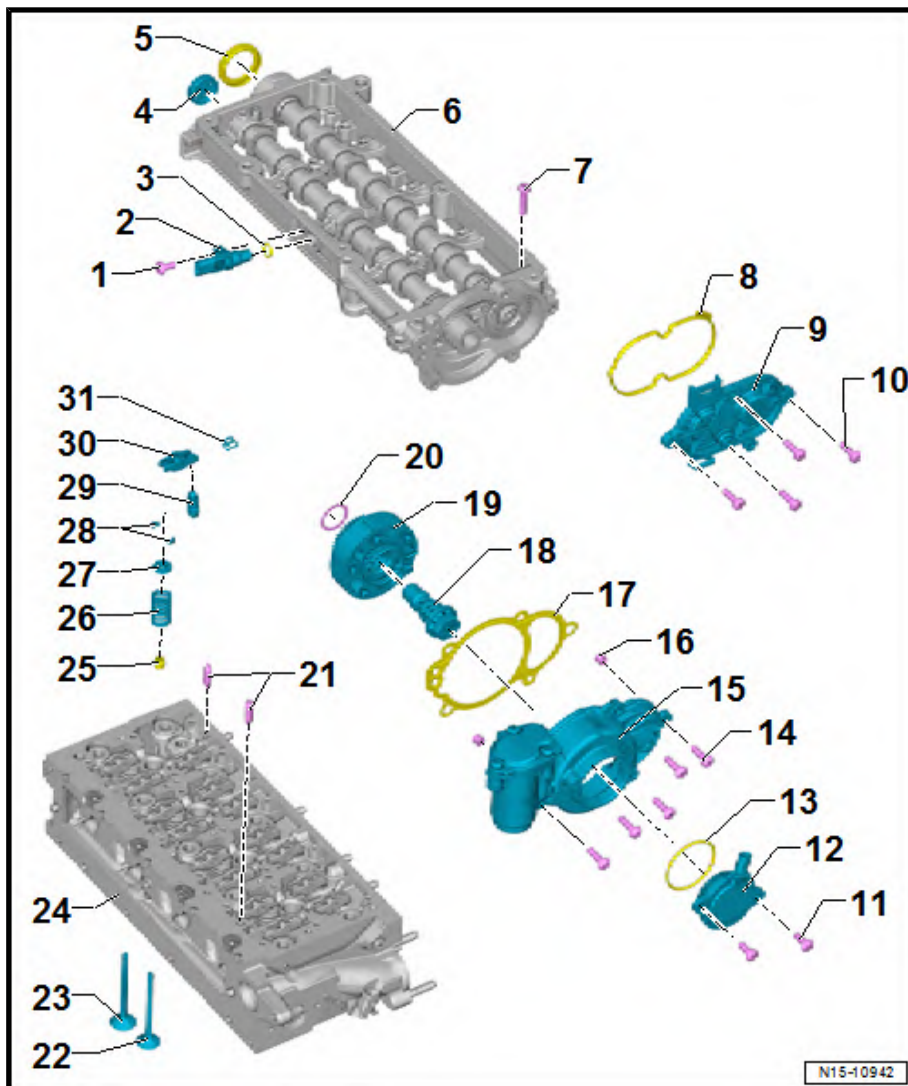

- Tightening torque and sequence ⇒ [page 140](#) .

#### 15 - Housing

- For camshaft adjuster
- Depending on version, not installed in all vehicles

#### 16 - Dowel sleeve

- Depending on version, not installed in all vehicles

#### 17 - Seal

- Depending on version, not installed in all vehicles
- Renew following removal

#### 18 - Control valve

- Depending on version, not installed in all vehicles
- 50 Nm
- Removing and fitting ⇒ [page 146](#)

#### 19 - Camshaft adjuster

 **Caution**

*A diamond-coated washer is used between the camshaft adjuster and camshaft journal ⇒ [Item 3 \(page 138\)](#) to secure the joint. Before installation it is imperative that this diamond washer is on the camshaft adjuster. Otherwise the camshaft adjuster can come loose during operation and cause damage to the engine.*

- Depending on version, not installed in all vehicles
- Removing and fitting ⇒ [page 143](#)

#### 20 - Friction washer

- Before the installation of the camshaft adjuster check it is fitted

#### 21 - Dowel pin

- For camshaft housing

#### 22 - Exhaust valve

- Do not rework. Only lapping in is permitted.
- Mark installation position for re-installation
- Checking ⇒ [page 158](#)
- Valve dimensions ⇒ [page 158](#) .
- Checking valve guides ⇒ [page 157](#) .

#### 23 - Inlet valve

- Do not rework. Only lapping in is permitted.
- Mark installation position for re-installation
- Checking ⇒ [page 158](#)
- Valve dimensions ⇒ [page 158](#) .
- Valve guides: check ⇒ [page 157](#)

#### 24 - Cylinder head

- Valve seats may not be machined due to the very small tolerances

**25 - Valve stem seal**

- Must be renewed if removed ⇒ [page 149](#) ,

**26 - Valve spring**

**27 - Valve spring plate**

**28 - Valve cotters**

**29 - Hydraulic compensation element**

- Checking ⇒ [page 148](#)
- Mark installation position for re-installation
- Lubricate contact surfaces before installing.

**30 - Roller rocker finger**

- Removing and fitting ⇒ [“1.6 Removing and installing camshaft housing”, page 107](#)
- Mark installation position for re-installation
- Check tapered roller bearing for ease of movement.
- Lubricate contact surfaces before installing.

**31 - Securing clip**

- For hydraulic compensation element

**Camshaft housing - tightening torque and sequence**

– Tighten bolts in stages in the sequence shown:

stage	Bolts	Tightening torque
1st	-1 ... 18-	Screw in by hand until they make contact <ul style="list-style-type: none"> <li>• The camshaft housing should make contact with the cylinder head over the full surface.</li> </ul>
3.	-1 ... 18-	8 Nm
2nd	-1 ... 18-	turn 90° further

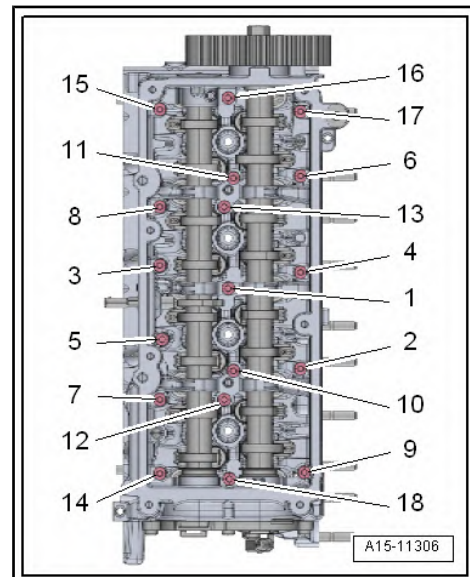

**Housing for camshaft adjuster - specified torque and sequence**

– Tighten bolts in stages in the sequence shown:

stage	Bolts	Tightening torque
1st	-1 ... 5-	Screw in by hand until they make contact
2nd	-1 ... 5-	8 Nm

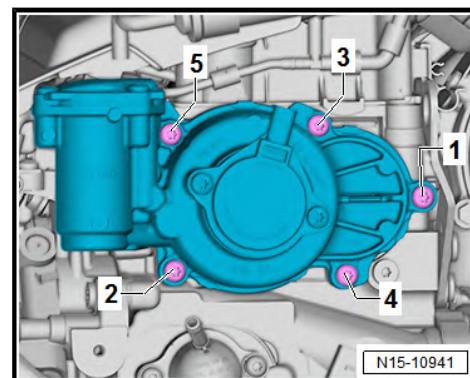

**3.2 Measuring axial play of camshaft**

Special tools and workshop equipment required

- ◆ Universal dial gauge bracket - VW 387-

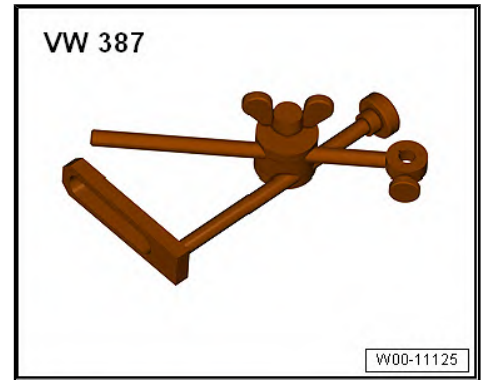

- ◆ Dial gauge - VAS 6079-

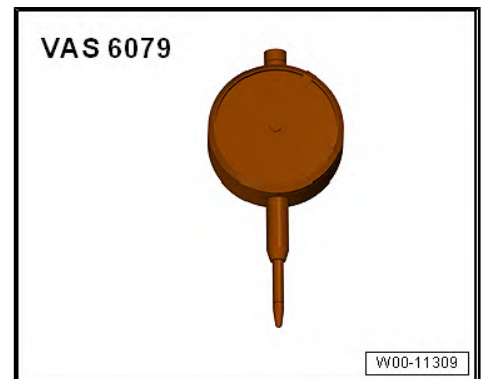

### Operation process

- Remove camshaft housing  
⇒ ["1.6 Removing and installing camshaft housing", page 107](#) .
- Secure dial gauge - VAS 6079- to camshaft housing with universal dial gauge bracket - VW 387- as shown in illustration.
- Press camshaft against dial gauge by hand.
- Set the dial gauge to "0".
- Press camshaft away from dial gauge and read off value:
  - Axial clearance: 0.05 ... 0.15 mm.

## 3.3 Removing and installing camshaft oil seal

### Special tools and workshop equipment required

- ◆ Puller - T10443-

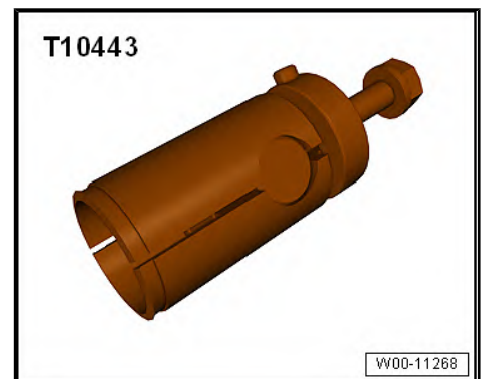

◆ Guide sleeve -T10493-

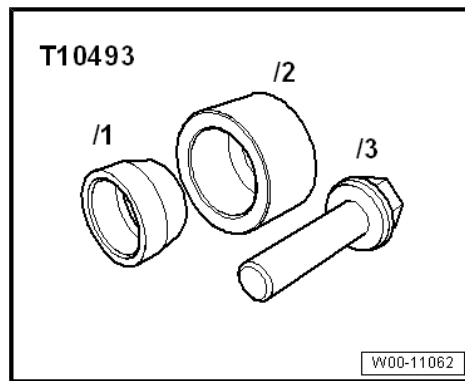

Operation process

- Detach toothed belt from camshaft ⇒ [page 132](#) .

**Caution**

◆ *If the grub screw is unscrewed too far the thrust plate inside the puller -T10443- will come loose from the thrust bolt. If this happens, the thrust plate must be pushed back onto the thrust bolt.*

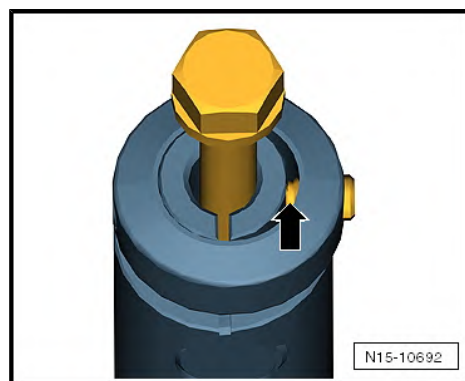

- Carefully unscrew grub screw -arrow- of puller -T10443- until slight resistance is felt.
- Apply puller - T10443- in a straight line, as shown in illustration, and lock by screwing in grub screw.-A-.
- Screw in thrust bolt -B- until oil seal is pulled out.
- Clean contact surface and sealing surface.

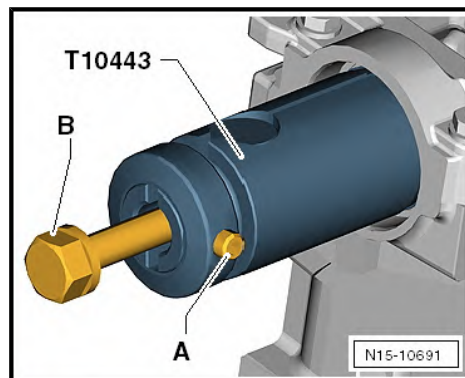

**Note**

*The oil seal sealing lip must not be additionally oiled or greased.*

- Fit guide sleeve -T10493/1- onto camshaft as shown in illustration.
- Carefully push oil seal -1- over guide sleeve and onto camshaft.

**Note**

*When pressing in oil seal, guide sleeve remains on camshaft as a stop.*

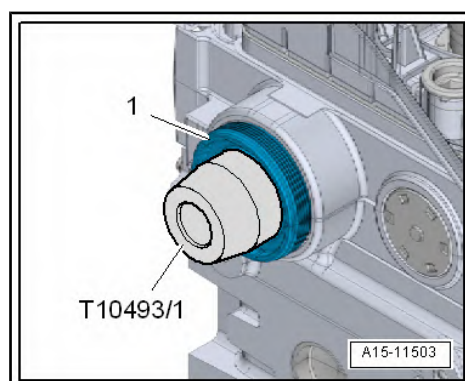

- Using press tool -T10493/2- and screw -T10493/3- press the shaft seal to the stop.
- Install notched belt (adjusting valve timing) ⇒ [page 136](#) .

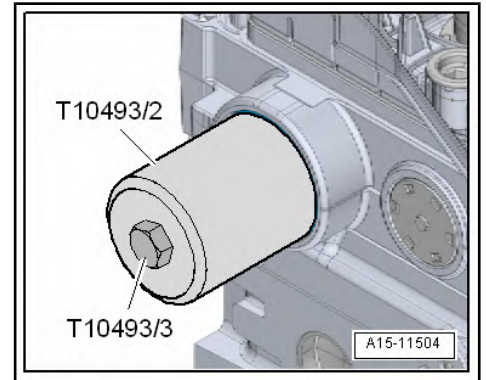

### 3.4 Removing and installing camshaft adjuster

#### Special tools and workshop equipment required

- ◆ Diesel injection pump locking pin - 3359-

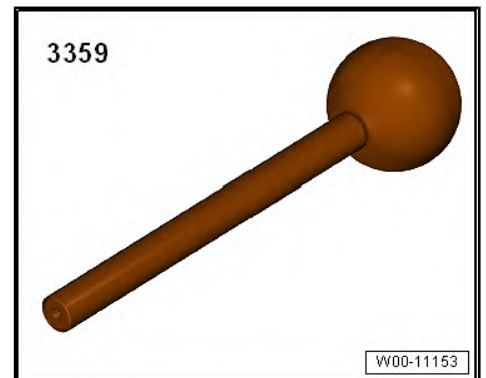

- ◆ Dowel pin - T10492-



#### Removal

- Remove toothed belt cover (top) ⇒ [page 116](#) .

- Remove noise insulation => General body repairs, exterior; Rep. gr. 66 ; Noise insulation; Remove and install noise insulation .



**Caution**

*Irreparable damage can be caused if the toothed belt slips.*

- ◆ *Turn crankshaft only in direction of engine rotation.*

- Turn crankshaft by the bolt for the toothed belt wheel until the crankshaft toothed belt pulley is positioned at "TDC".

Remove the camshaft as described in the following:

- Disconnect plug-in connector -2- in the injector unit for cylinder 1.
- Unlock cap -1- in the cylinder head cover, turn anti-clockwise and remove.

- Lock inlet camshaft with the dowel pin - T10492- taking the following into account:

Cylinder head cover -1- installed:

- Clearance -a- is approx. 1 mm.

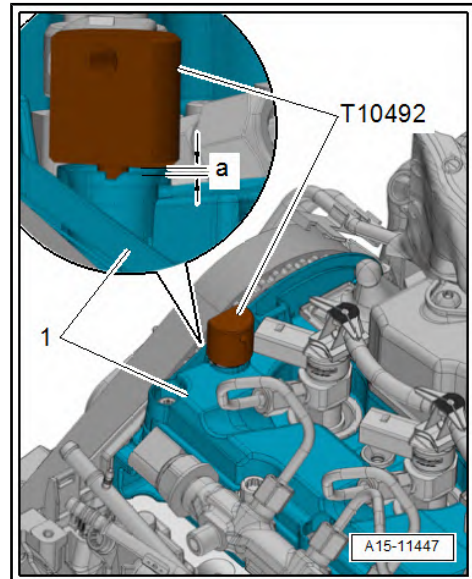
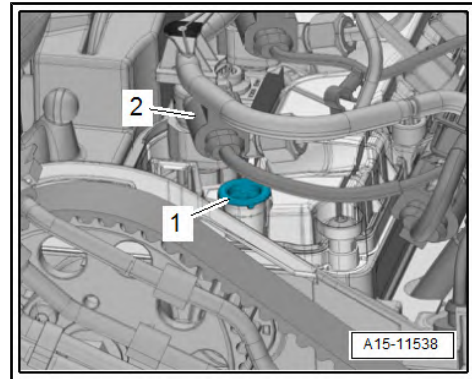
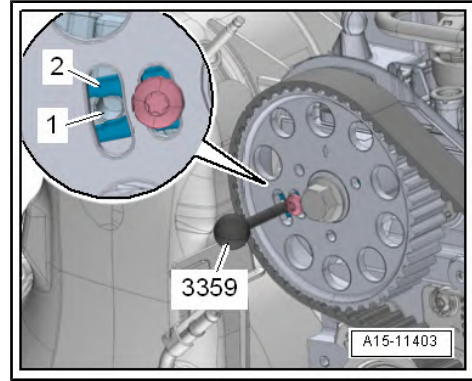

Cylinder head cover removed:

- The groove -1- of the dowel pin - T10492- must finish camshaft housing -2-.
- For reasons of space, remove the air filter housing together with the intake hose ⇒ [page 321](#) .

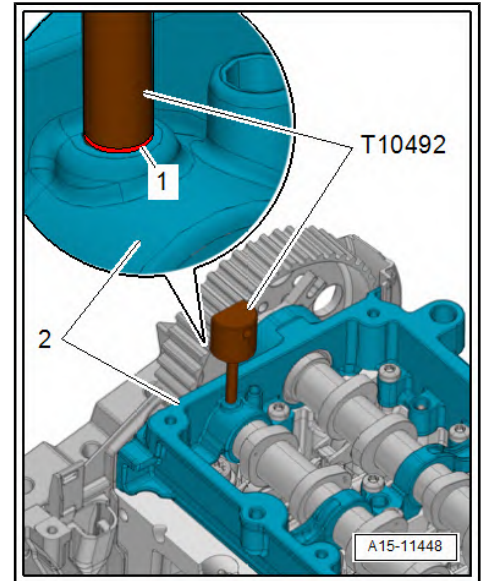

- Unplug electrical connectors -3- and -4-. Remove the retaining clip from the cover.
- Remove the screws -2- and remove the cover -1-.



**Caution**

*Before removal of the control valve the small piston in the centre of the valve is to be checked for free movement. Press with a finger on the piston and check whether it can be pushed in and whether it subsequently returns to its end position. If the piston jams, the valve is to be renewed. Otherwise there is a risk of engine damage.*

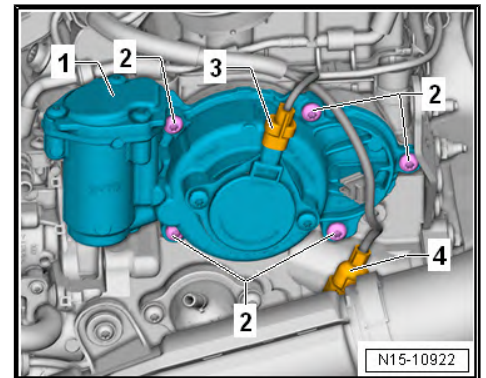

- Screw out the control valve -2- and remove the camshaft adjuster -1-.

**Installation**



**Caution**

*A diamond-coated washer is used between the camshaft adjuster and camshaft journal to secure the joint. Before installation it is imperative that this diamond washer is on the camshaft adjuster. Otherwise the camshaft adjuster can come loose during operation and cause damage to the engine.*

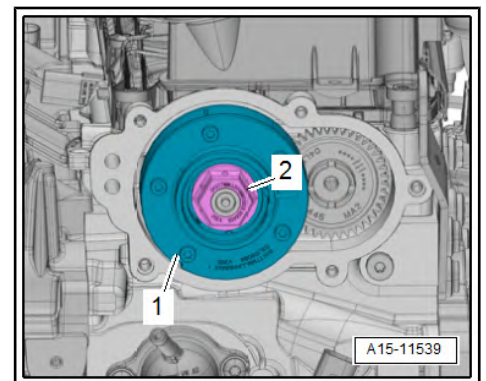

Installation is carried out in the reverse order; note the following:

- Install toothed belt cover (top) ⇒ [page 116](#) .

**Specified torques**

- ◆ Assembly overview - valve gear ⇒ [“3.1 Assembly overview - valve gear”, page 137](#)
- ◆ Assembly overview noise insulation ⇒ Rep. gr. 66 ; Noise insulation; Assembly overview - Noise insulation

### 3.4.1 Removing and installing control valve for the camshaft adjuster



#### Note

If a fault is diagnosed for the control valve ⇒ *Item 18 (page 139) (25) of the camshaft adjuster*, the camshaft adjuster itself must not be renewed. Only the control valve must be renewed.

- Remove toothed belt cover (top) ⇒ [page 116](#) .
- Remove noise insulation ⇒ General body repairs, exterior; Rep. gr. 66 ; Noise insulation; Remove and install noise insulation .



#### Caution

*Irreparable damage can be caused if the toothed belt slips.*

- ◆ *Turn crankshaft only in direction of engine rotation.*

- Turn crankshaft by the bolt for the toothed belt wheel until the crankshaft toothed belt pulley is positioned at "TDC".

Remove the camshaft as described in the following:

- Disconnect plug-in connector -2- in the injector unit for cylinder 1.
- Unlock cap -1- in the cylinder head cover, turn anti-clockwise and remove.

- Lock inlet camshaft with the dowel pin - T10492- taking the following into account:

Cylinder head cover -1- installed:

- Clearance -a- is approx. 1 mm.

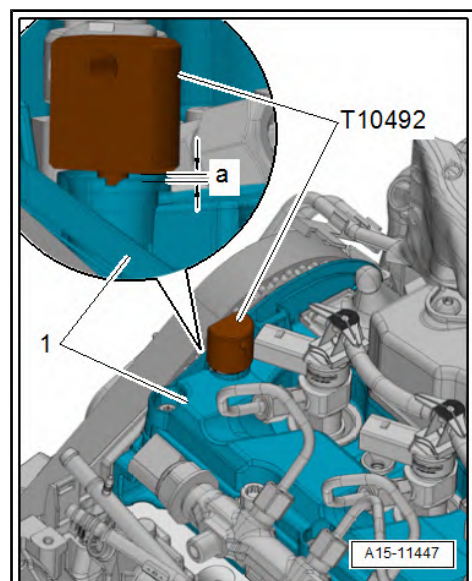
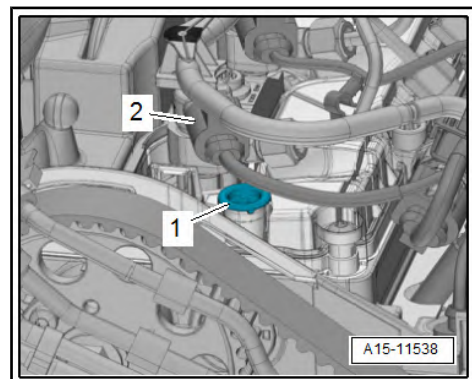
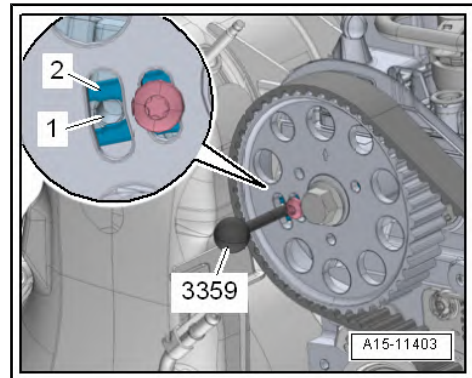

Cylinder head cover removed:

- The groove -1- of the dowel pin - T10492- must finish camshaft housing -2-.
- Remove air cleaner housing ⇒ [page 320](#) .
- Unplug the electrical connector -2-.

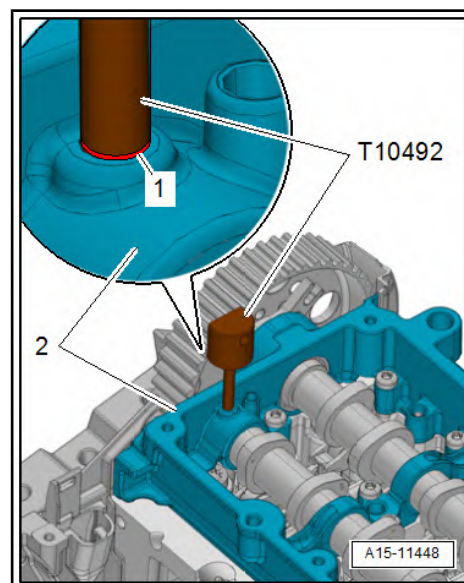

- Unscrew bolt -1- and remove camshaft control valve 1 - N205- .



*To improve illustration the control valve -2- and the camshaft adjuster -1- are shown without covers.*

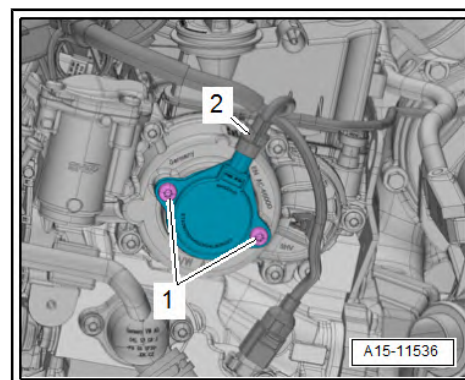

- Screw out the control valve -2-.

### Installation

Install in reverse order to dismantling, noting the following:

- Install toothed belt cover (top) ⇒ [page 116](#) .

### Specified torques

- ◆ Assembly overview - valve gear ⇒ [“3.1 Assembly overview - valve gear”, page 137](#)
- ◆ Assembly overview - Noise insulation ⇒ General body repairs, exterior; Rep. gr. 66 ; Noise insulation; Assembly overview - Noise insulation .

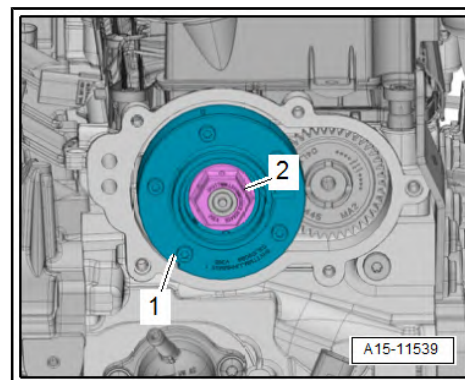

### 3.5 Valve 1 for variable distribution - N205- : removing and fitting

#### Removal

- Remove air cleaner housing ⇒ [page 320](#) .
- Unplug the electrical connector -2-.
- Unscrew bolt -1- and remove camshaft control valve 1 - N205- .

#### Installation

Installation is carried out in the reverse order; note the following:



#### Note

*Renew O-ring.*

#### Specified torques

- ◆ Assembly overview - valve gear  
⇒ [“3.1 Assembly overview - valve gear”, page 137](#)
- ◆ Assembly overview - air filter housing  
⇒ [“4.1 Exploded view - air cleaner housing”, page 319](#)

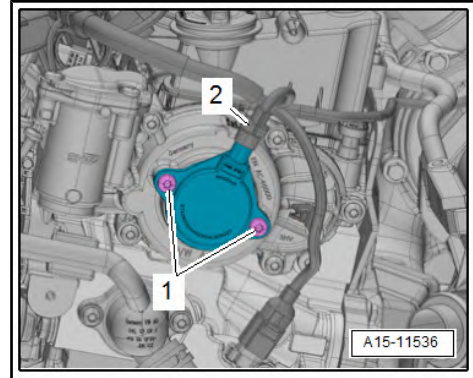

### 3.6 Checking hydraulic valve compensation elements



#### Note

- ◆ *The hydraulic compensation elements cannot be repaired.*
- ◆ *Irregular valve noises when starting engine are normal.*

#### Special tools and workshop equipment required

- ◆ Feeler gauge

#### Operation process

- Start engine and run until radiator fan has started up once.
- Increase engine speed to approx. 2,500 rpm for 2 minutes (perform road test if necessary).



#### Note

*If irregular valve noise disappears but repeatedly re-occurs when travelling short distances, renew oil retention valve. The oil retention valve is located in the oil filter housing*  
⇒ [Item 9 \(page 169\)](#) .

- If the compensation elements are still noisy, locate the defective compensation element as follows:
- Removing and fitting the cylinder head cover ⇒ [page 103](#) .
- Rotate crankshaft by turning bolt for toothed belt sprocket until cam of supporting element to be tested is facing upwards.

- Press roller rocker finger down -arrow- to determine clearance between cam and roller rocker finger.
- If it is possible to insert a feeler gauge of 0.20 mm between cam and roller rocker finger, renew hydraulic compensation element  
⇒ [“1.6 Removing and installing camshaft housing”](#), page 107 .

**Additional steps required**

- Install the cylinder head cover ⇒ [page 103](#) .

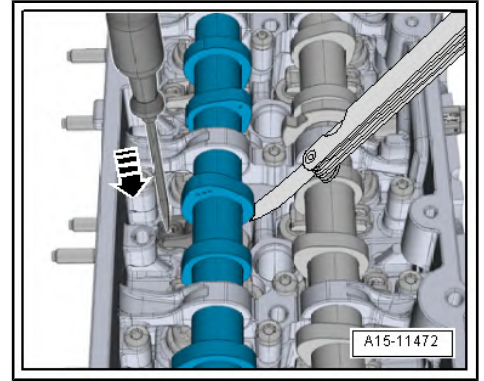

### 3.7 Removing and installing valve stem seals

⇒ [“3.7.1 Removing and installing valve stem oil seals \(cylinder head installed\)”](#), page 149

⇒ [“3.7.2 Removing and installing valve stem oil seals \(cylinder head removed\)”](#), page 152

#### 3.7.1 Removing and installing valve stem oil seals (cylinder head installed)

**Special tools and workshop equipment required**

- ◆ Valve stem seal puller - 3364-



- ◆ Valve stem seal fitting tool - 3365-



- ◆ Removal and installation device for valve cotters - VAS 5161- with sealing pin -VAS 5161/29-2- , guide plate -VAS 5161A/31- and sleeve -VAS 5161/31-1- .

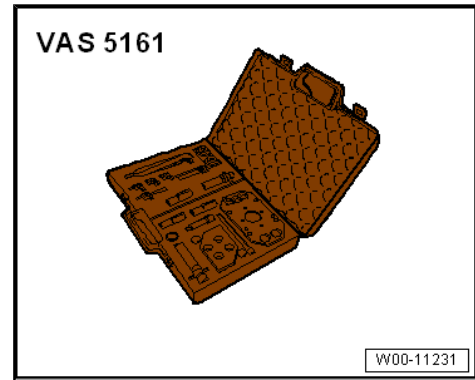

### Operation process

- Remove all glow plugs ⇒ [page 443](#) .
- Remove camshaft housing ⇒ [page 107](#) .
- Mark original positions of roller rocker fingers and hydraulic compensation elements for re-installation.
- Remove roller rocker fingers together with hydraulic compensation elements and place down on a clean surface.
- Set piston of the respective cylinder to “bottom dead centre”.

### Cylinders 1, 3, 4:

- Fit guide plate -VAS 5161/31- onto cylinder head.
- The lettering -A- faces towards turbocharger side
- The lettering -E- faces towards intake manifold side
- Secure guide plate with knurled screws -VAS 5161/12- by hand.
- Position of knurled screws, as shown in illustration

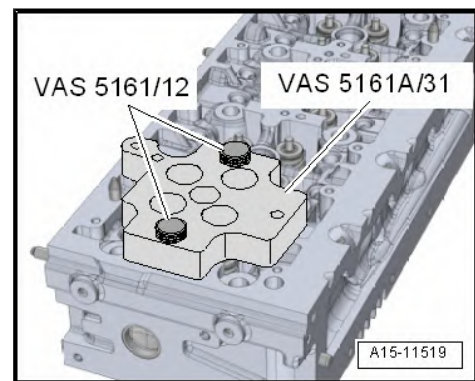

### Cylinder 2:

- Fit guide plate -VAS 5161/31- onto cylinder head.
- The lettering -A- faces towards turbocharger side
- The lettering -E- faces towards intake manifold side
- Secure guide plate with knurled screws -VAS 5161/12- by hand.
- Position of knurled screws, as shown in illustration

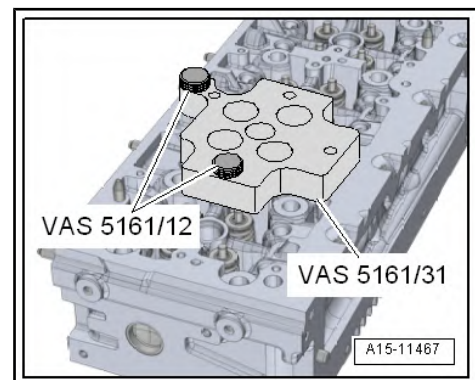

**Continued for all cylinders:**

- Screw sealing pin -VAS 5161/29-2- into guide plate.
- Screw adapter -VAS 5161/11- hand-tight into corresponding glow plug thread.

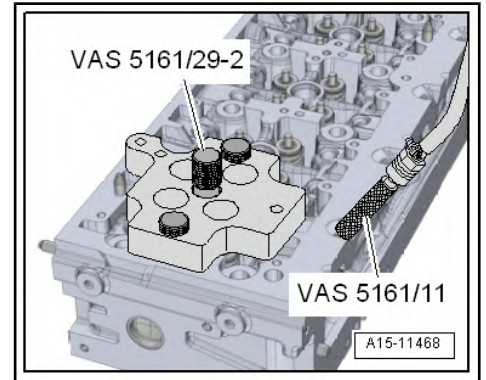

- Insert drift -VAS 5161/3A- into guide plate and use plastic-headed hammer to release sticking valve cotters.

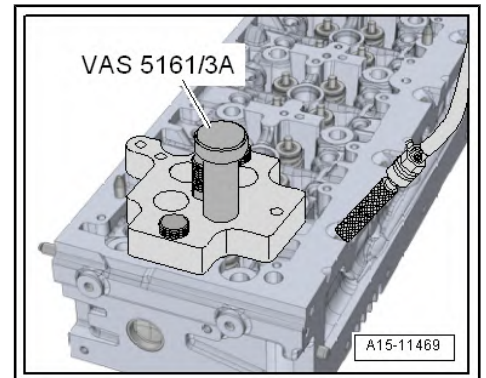

- Screw snap-in device -VAS 5161/6- with engaging fork -VAS 5161/5- into guide plate.
- Insert assembly cartridge -VAS 5161/8- (slide on sleeve -VAS 5161/31-1- ) in guide plate.
- Connect adapter to compressed air line using a commercially available connection piece, and apply constant air pressure.
  - Minimum pressure: 6 bar
- Attach pressure fork -VAS 5161/2- to snap-in device and push assembly cartridge down.
- At the same time, turn knurled screw of assembly cartridge clockwise until tips engage in valve cotters.
- Move knurled screw back and forth to press apart valve cotters and capture them in assembly cartridge.
- Release pressure fork.
- Take off assembly cartridge with sleeve.
- Detach valve spring with valve spring plate.
- Pull off valve stem oil seal with valve stem seal puller - 3364- .

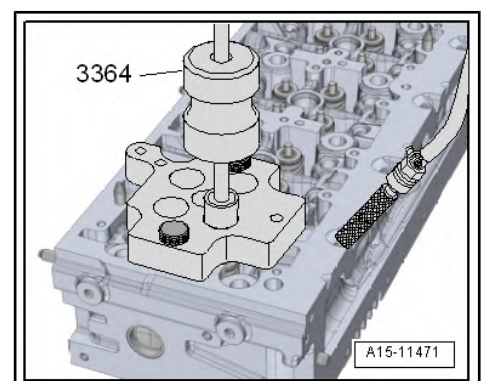
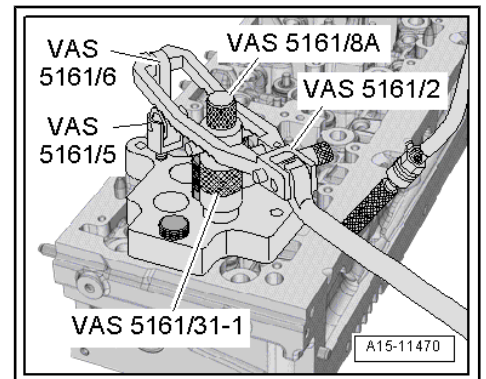



**Caution**

*Make sure valve stem oil seals are not damaged when installing.*

- ◆ *New valve stem oil seals -B- are supplied with plastic sleeve; fit plastic sleeve -A- onto valve stem.*

- Lightly oil sealing lip of valve stem seal.
- Slide valve stem oil seal onto plastic sleeve.
- Carefully press valve stem oil seal onto valve guide using valve stem seal fitting - 3365- tool.
- Remove plastic sleeve.

If valve cotters have been removed from assembly cartridge, they must first be inserted in insertion device -VAS 5161/18- .

- Larger diameter of valve cotters faces upwards.
- Position the valve spring and the valve spring plate.
- Press assembly cartridge onto insertion device from above and take up valve cotters.

- Insert assembly cartridge into guide plate -VAS 5161/31- again.
- Press the pressure fork together and pull upwards towards the knurled screw and at the same time turn towards the left and right. The valve cones are mounted in this way.
- Release pressure fork with knurled screw still in pulled position.
- Repeat procedure for each valve.

**Assembling**

Installation is carried out in the reverse order; note the following:

- Ensure that all roller rocker fingers make contact with the ends of the valve stems correctly and are clipped onto their respective hydraulic compensation elements.
- Fit camshaft housing ⇒ [page 107](#) .
- Install glow plugs ⇒ [page 443](#) .

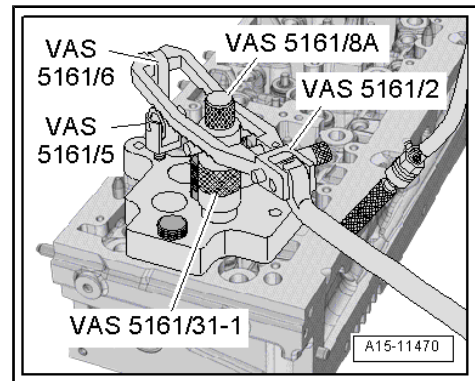
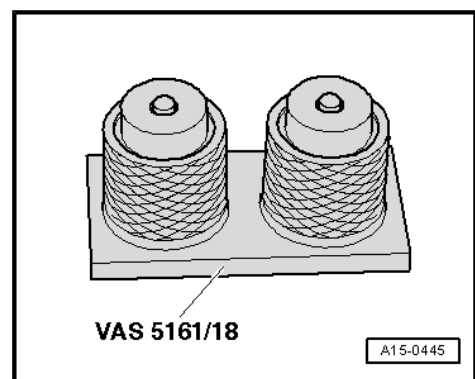
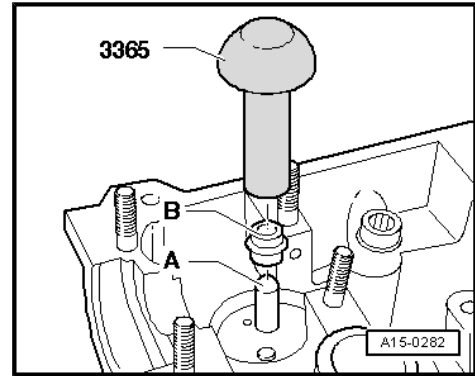

### 3.7.2 Removing and installing valve stem oil seals (cylinder head removed)

### Special tools and workshop equipment required

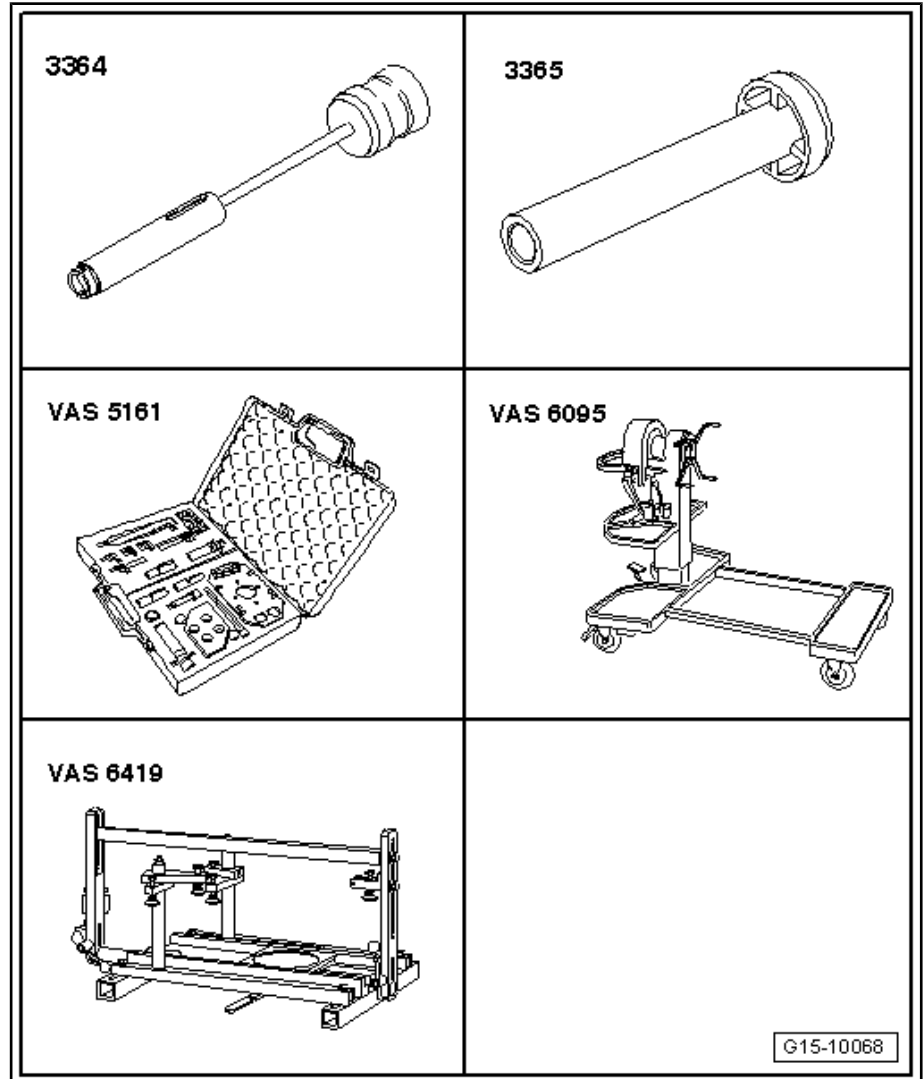

- ◆ Valve stem seal puller - 3364-
- ◆ Valve stem seal fitting tool - 3365-
- ◆ Removal and installation device for valve cotters - VAS 5161- with guide plate -VAS 5161A/31- and sleeve -VAS 5161/31-1- .
- ◆ Engine and gearbox support - VAS 6095-
- ◆ Cylinder head tensioning device - VAS 6419-

### Operation process

#### Prerequisites:

- Intake manifold removed ⇒ [page 323](#)
- Exhaust manifold/turbocharger is removed ⇒ [page 252](#) .
- Remove camshaft housing ⇒ [page 107](#) .
- Mark original positions of roller rocker fingers and hydraulic compensation elements for re-installation.
- Remove roller rocker fingers together with hydraulic compensation elements and place down on a clean surface.
- Insert cylinder head tensioning device - VAS 6419- into engine and gearbox support - VAS 6095- .

- Secure cylinder head in cylinder head tensoning device, as shown in illustration.
- Connect cylinder head tensoning device to compressed air.
- Use lever -arrow- to slide air cushion under combustion chamber from which valve stem seal is to be removed.
- Apply just enough compressed air to bring air pad into contact with valve heads.

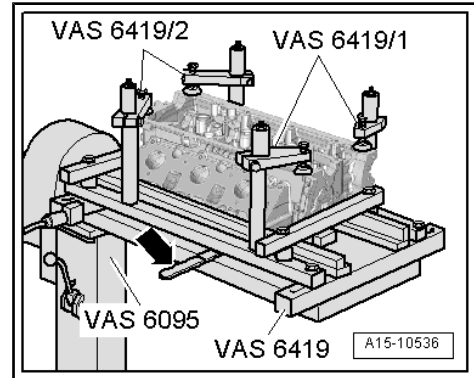

**Cylinders 1, 3, 4:**

- Fit guide plate -VAS 5161/31- onto cylinder head.
- The lettering -A- faces towards turbocharger side
- The lettering -E- faces towards intake manifold side
- Secure guide plate with knurled screws -VAS 5161/12- by hand.
- Position of knurled screws, as shown in illustration

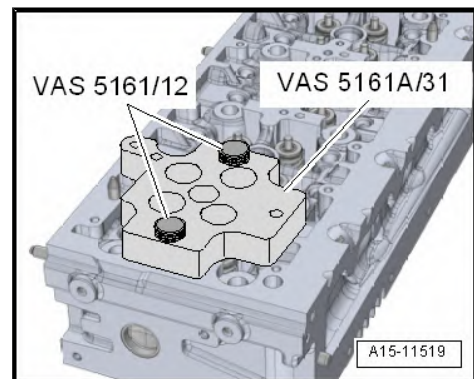

**Cylinder 2:**

- Fit guide plate -VAS 5161/31- onto cylinder head.
- The lettering -A- faces towards turbocharger side
- The lettering -E- faces towards intake manifold side
- Secure guide plate with knurled screws -VAS 5161/12- by hand.
- Position of knurled screws, as shown in illustration

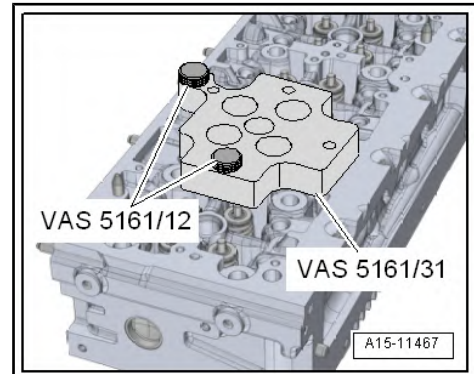

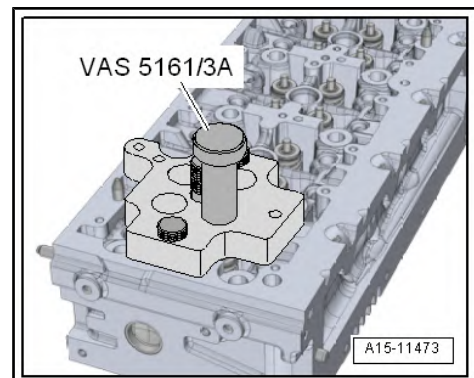

**Continued for all cylinders:**

- Insert drift -VAS 5161/3A- into guide plate and use plastic-headed hammer to release sticking valve cotters.

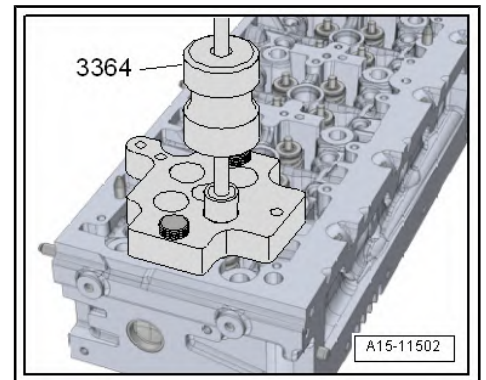
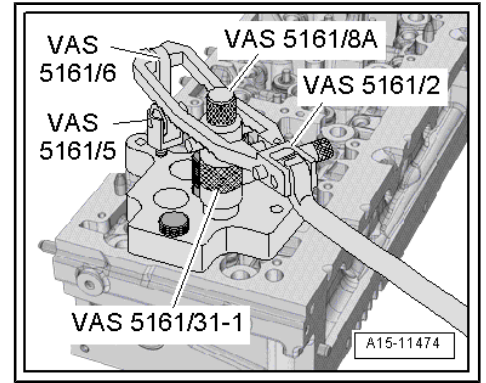

- Screw snap-in device -VAS 5161/6- with engaging fork - VAS 5161/5- into guide plate.
- Insert assembly cartridge -VAS 5161/8- (slide on sleeve - VAS 5161/31-1- ) in guide plate.
- Attach pressure fork -VAS 5161/2- to snap-in device and push assembly cartridge down.
- At the same time, turn knurled screw of assembly cartridge clockwise until tips engage in valve cotters.
- Move knurled screw back and forth to press apart valve cotters and capture them in assembly cartridge.
- Release pressure fork.
- Take off assembly cartridge with sleeve.
- Detach valve spring with valve spring plate.
- Pull off valve stem oil seal with valve stem seal puller - 3364- .



 **Caution**

*Make sure valve stem oil seals are not damaged when installing.*

◆ *New valve stem oil seals -B- are supplied with plastic sleeve; fit plastic sleeve -A- onto valve stem.*

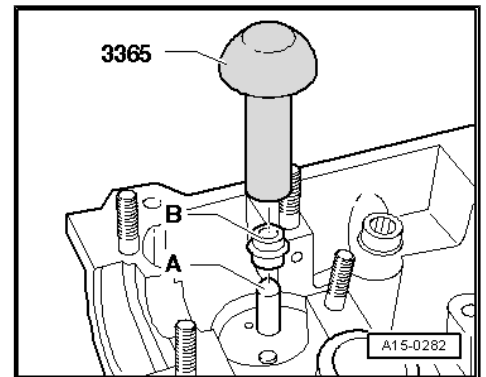

- Lightly oil sealing lip of valve stem seal.
- Slide valve stem oil seal onto plastic sleeve.
- Carefully press valve stem oil seal onto valve guide using valve stem seal fitting - 3365- tool.
- Remove plastic sleeve.

If valve cotters have been removed from assembly cartridge, they must first be inserted in insertion device -VAS 5161/18- .

- Larger diameter of valve cotters faces upwards.
- Press assembly cartridge onto insertion device from above and take up valve cotters.
- Position the valve spring and the valve spring plate.

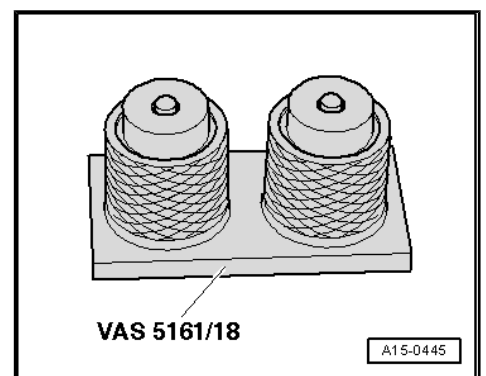

- Insert assembly cartridge into guide plate -VAS 5161/31- again.
- Press the pressure fork together and pull upwards towards the knurled screw and at the same time turn towards the left and right. The valve cones are mounted in this way.
- Release pressure fork with knurled screw still in pulled position.
- Repeat procedure for each valve.

### Assembling

Installation is carried out in the reverse order; note the following:

- Ensure that all roller rocker fingers make contact with the ends of the valve stems correctly and are clipped onto their respective hydraulic compensation elements.
- Fit camshaft housing ⇒ [page 107](#) .

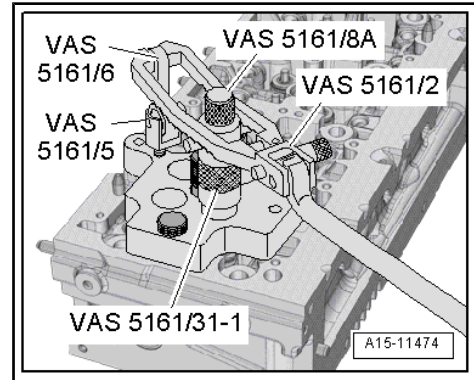

## 4 Inlet and exhaust valves

⇒ [“4.1 Valve guides: verification”, page 157](#)

⇒ [“4.2 Valves: checking”, page 158](#)

⇒ [“4.3 Valve dimensions”, page 158](#)

### 4.1 Valve guides: verification

Special tools and workshop equipment required

- ◆ Universal dial gauge bracket - VW 387-

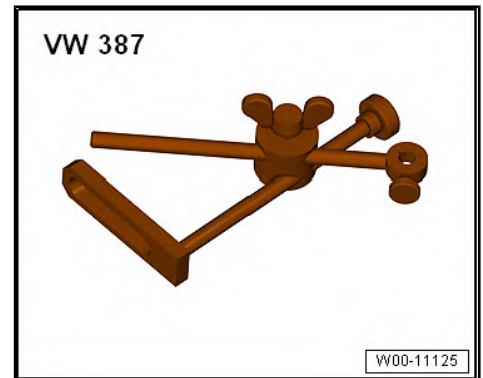

- ◆ Dial gauge - VAS 6079-

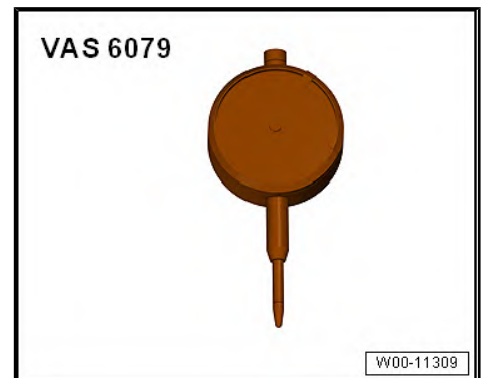

#### Operation process



#### Note

- ◆ *If the valve has to be renewed as part of a repair, use a new valve for the measurement.*
- ◆ *Only insert inlet valve into inlet valve guide and exhaust valve into exhaust valve guide, as the stem diameters are different.*

- Attach dial gauge - VAS 6079- with dial gauge bracket - VW 387- to cylinder head.
- Insert valve into valve guide.
- The end of the valve stem must be flush with the guide.
- Determine rock.
- Wear limit: 1.0 mm.
- If the wear limit is exceeded, repeat the measurement with new valves.
- Renew cylinder head if wear limit is still exceeded.

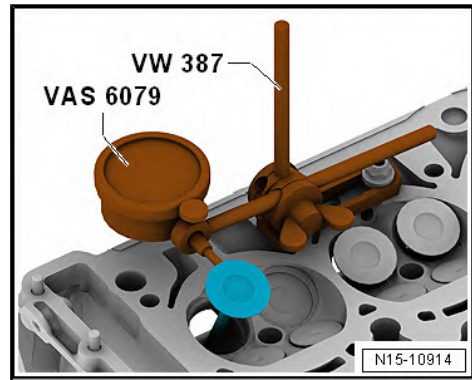

**i** Note

*Valve guides cannot be exchanged.*

## 4.2 Valves: checking

- Visually inspect for scoring on valve stems and valve seat surfaces.
- Renew valve if scoring is clearly visible.

## 4.3 Valve dimensions

**i** Note

*Inlet and exhaust valves must not be reworked. Only grinding-in is permitted.*

Dim.		Inlet valve	Exhaust valve
∅ a	mm	28.10	26.00
∅ b	mm	5.975	5.965
c	mm	99.30	99.10
α	∠°	45	45

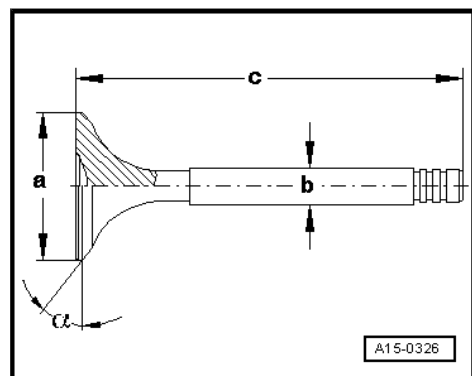

## 17 – Lubrication

### 1 Sump, oil pump

⇒ [“1.1 Exploded view - sump/oil pump”, page 159](#)

⇒ [“1.2 Engine oil”, page 161](#)

⇒ [“1.3 Removing and replacing oil sump”, page 161](#)

⇒ [“1.4 Oil pump: removing and installing”, page 166](#)

⇒ [“1.5 Removing and installing oil level and oil temperature sender G266”, page 166](#)

#### 1.1 Exploded view - sump/oil pump



##### Note

- ◆ *If large quantities of metal chips and abraded material are found during engine repair, this may indicate that the crankshaft bearings or conrod bearings are damaged. To prevent further damage, please carry out the following steps after completion of repair work: clean the oil lines carefully and renew the oil spray nozzle, engine oil cooler and oil filter.*
- ◆ *Oil jets and pressure release valve ⇒ [page 84](#)*

**1 - Bolt.**

- Self-locking
- Renew following removal
- 8 Nm

**2 - Oil level/oil temperature sensor - G266-**

- Removing and fitting ⇒ [page 166](#)

**3 - Oil seal**

- Renew following removal

**4 - Oil drain plug**

- 30 Nm

**5 - Oil seal**

- Renew following removal

**6 - Bolt.**

- Tightening torque and sequence ⇒ [page 161](#) .

**7 - Oil sump**

- Removing and fitting ⇒ [page 161](#)

**8 - O-ring**

- Renew following removal

**9 - Bolt.**

- Renew following removal

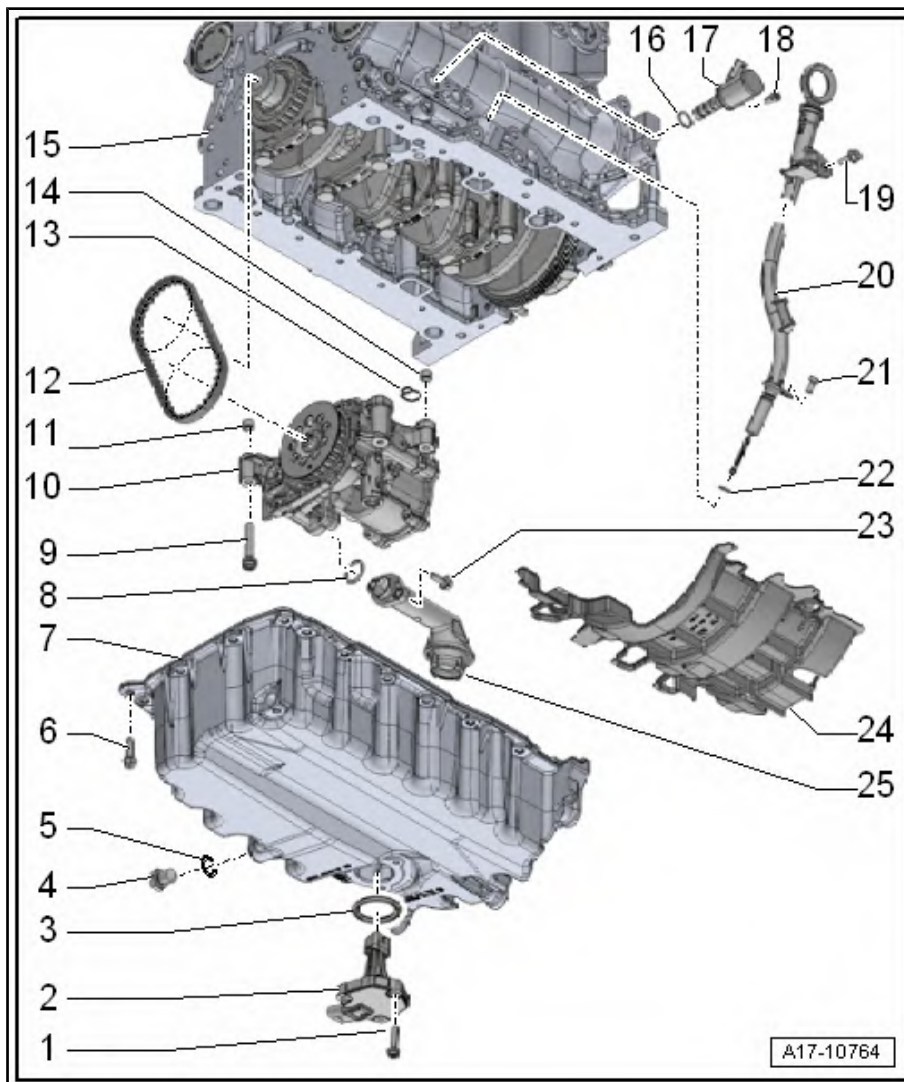

Different types of bolted connections:

- ◆ Internal torx screw head, 12 Nm + 180°
- ◆ External hexagon bolt: 10 Nm + 180°

**10 - Oil pump**

- With vacuum pump
- Removing and fitting ⇒ [page 166](#)

**11 - Dowel sleeve**

**12 - Toothed belt**

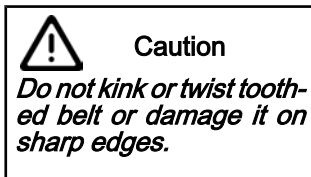

- Removing:

- ◆ ⇒ ["1.4 Oil pump: removing and installing", page 166](#)
- ◆ ⇒ ["1.8 Removing and installing sealing flange - pulley end", page 64](#)

**13 - Seal**

- Renew following removal

14 - Dowel sleeve

15 - Cylinder block

16 - O-ring

- Renew following removal

17 - Valve for oil pressure control - N428-

- Removing and fitting => [page 174](#)

18 - Bolt.

- 8 Nm

19 - Bolt.

- 8 Nm

20 - Guide tube for oil dipstick

21 - Bolt.

- 8 Nm

22 - O-ring

- Renew following removal

23 - Bolt.

- 8 Nm + 90°

24 - Oil separator

25 - Oil suction pipe

#### Sump - tightening torque and sequence

- Tighten bolts in stages as follows:

Stage	Bolt	Tightening torque
1	-1 ... 20-	diagonally, 5 Nm
2	-arrows-	40 Nm
3	-1 ... 20-	Tighten in stages and in diagonal sequence; final torque 13 Nm

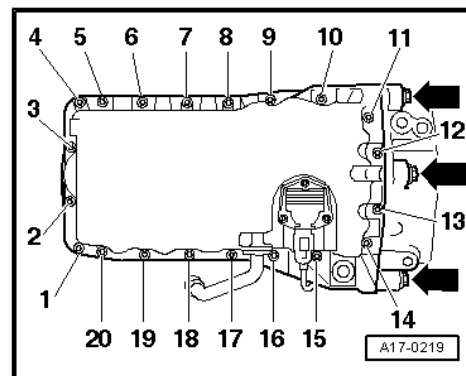

## 1.2 Engine oil

Oil specifications and viscosity grades => Maintenance ; Booklet 501 .

### Engine oil filling levels

=> Maintenance ; Booklet 501

## 1.3 Removing and replacing oil sump

Special tools and workshop equipment required

- ◆ 10 mm articulated wrench - 3185-

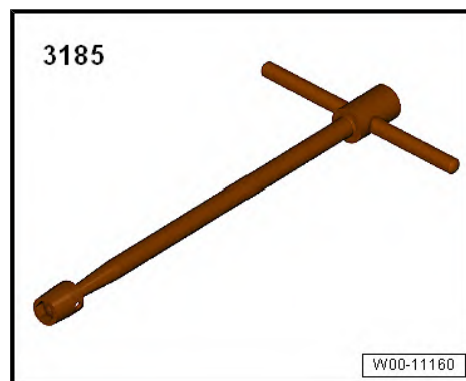

- ◆ Socket - T10058-



- ◆ Torque wrench - V.A.G 1331-



- ◆ Applicator gun - VAS 6966-

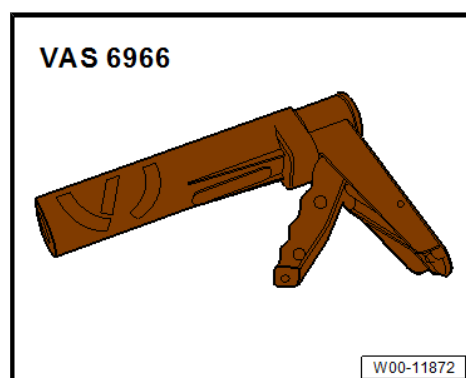

- ◆ Hand drill with plastic brush
- ◆ Sealant ⇒ Electronic parts catalogue
- ◆ Protective glasses

## Removal

- Engine oil drained ⇒ Maintenance ; Booklet 501
- Remove noise insulation -1- ⇒ General body repairs, exterior; Rep. gr. 66 ; Noise insulation; Remove and install noise insulation .
- Unplug electrical connector -arrow- at oil level and oil temperature sender - G266- .

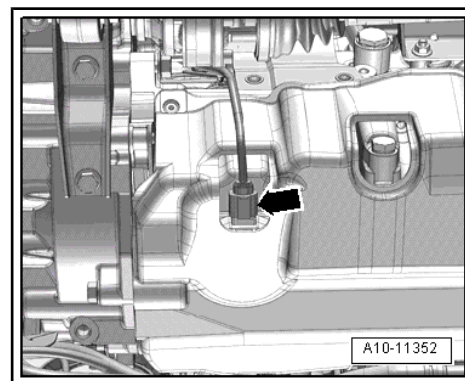

- Release clips -arrows- and detach noise insulation -1- for sump.
- Unscrew the oil drain plug from the oil sump and drain the engine oil.
- Remove bolts securing sump to gearbox -arrows-.

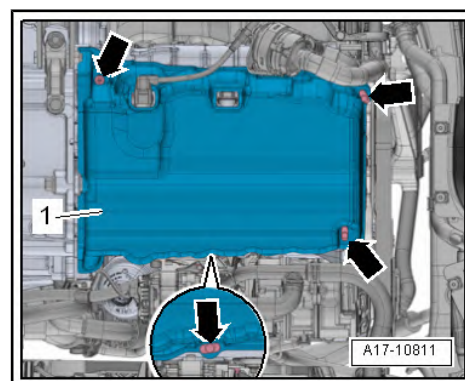

- Remove bolts securing sump to gearbox -arrows-.
- Slacken bolts -1 ... 20- in diagonal sequence and remove.
- Carefully release sump from bonded joint.

## Installation

 **Caution**

*Avoid soiling lubrication system and bearings.*

◆ *Cover open parts of engine.*

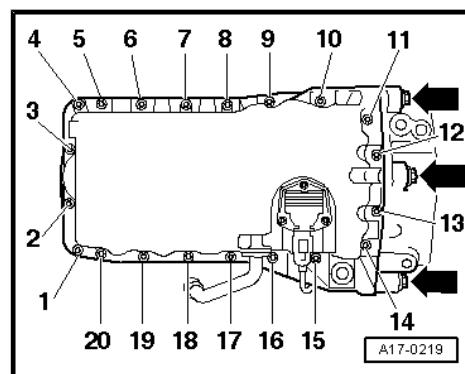

 **WARNING**

*Wear protective gloves when working with sealant and grease remover!*

- Remove sealant residue on cylinder block and oil pan using commercially available, chemical sealant remover.

- Remove sealant residue from sump using rotating plastic brush.
- Clean sealing surfaces; they must be oil and grease free.

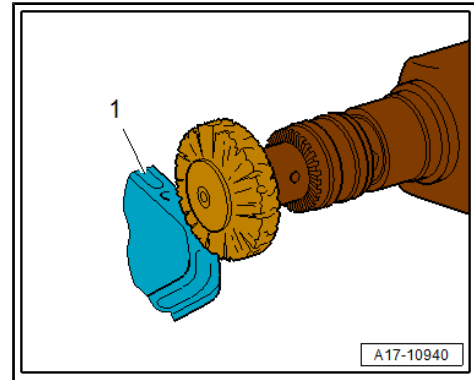

**i Note**

*Note the use-by date of the sealant.*

- Cut off nozzle on tube at front marking (∅ of nozzle approx. 2 ... 3 mm).

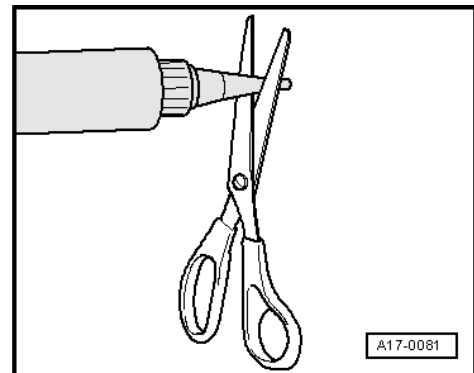

**Caution**

***Danger of blocking lubrication system with excess sealant.***

- ◆ ***Do not apply sealant bead thicker than specified.***

**If sealing flange on belt pulley end has not been renewed**

**i Note**

*After removing the old silicon seal, the lower surface of the sealing flange has an offset of approx. 1 mm on the pulley side toward the lower cylinder block surface. The offset must be compensated by applying sealant to the relevant section.*

- Apply bead of sealant onto clean sealing surface of sump as illustrated.
- Use applicator gun - VAS 6966- , as necessary, for applying.
- ◆ In area of sealing surface of sealing flange on belt pulley end -between arrows-: 3 ... 4 mm.
- ◆ In area of sealing surfaces of cylinder block and sealing flange on gearbox side: 2 ... 3 mm.
- The sealant bead in the area of the sealing flange on belt pulley end must be able to substitute the no longer existent silicone gasket in terms of height and width.

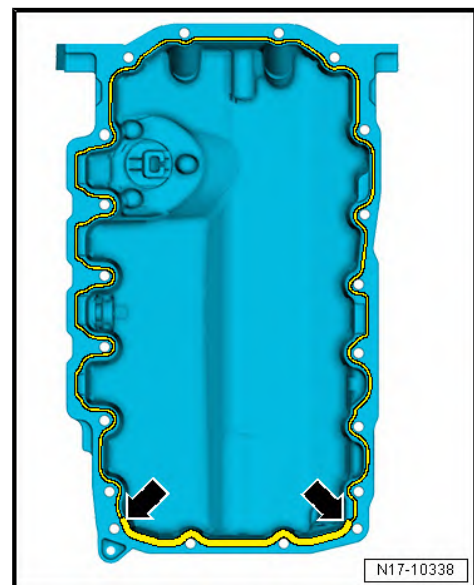

**i Note**

*The sump must be installed within 5 minutes after applying the sealant.*

#### If sealing flange on belt pulley end has been renewed

- Apply bead of sealant onto clean sealing surface of sump as illustrated.
- Use applicator gun - VAS 6966- , as necessary, for applying.
- ◆ Thickness of sealant bead: 2 ... 3 mm.

#### Note

- ◆ *Take particular care when applying sealant bead in area of sealing flanges.*
- ◆ *The sump must be installed within 5 minutes after applying the sealant.*

#### Continuation for both procedures

- Insert baffle plate.
- Position oil sump and tighten bolts ⇒ [page 161](#)
- The sump must make flush contact with intermediate plate/ gearbox flange.

#### Note

- ◆ *When installing sump with engine removed, ensure that sump is flush with cylinder block at flywheel end.*
- ◆ *After fitting sump assembly, the sealant must dry for approx. 30 minutes. Then (and only then) fill the engine with engine oil.*
- Fill with engine oil and check oil level ⇒ Maintenance ; Booklet 501 .

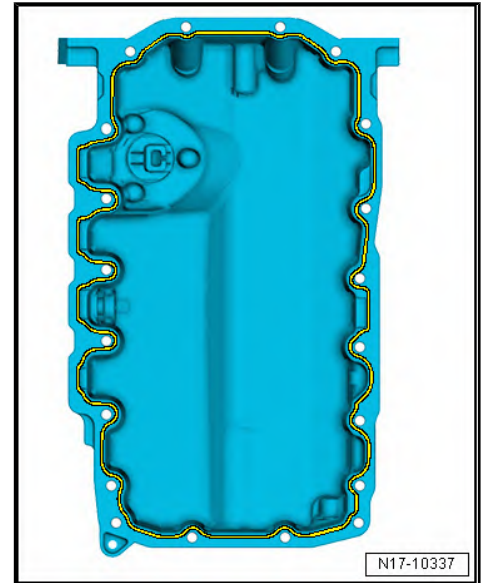

## 1.4 Oil pump: removing and installing

### Removal

- Remove the oil sump ⇒ [page 161](#) .



#### Caution

*Do not kink or twist toothed belt or damage it on sharp edges.*

- Remove bolts -arrows- and detach oil pump -1-.



#### Caution

*The bolt on the pump impeller must NOT be loosened.*

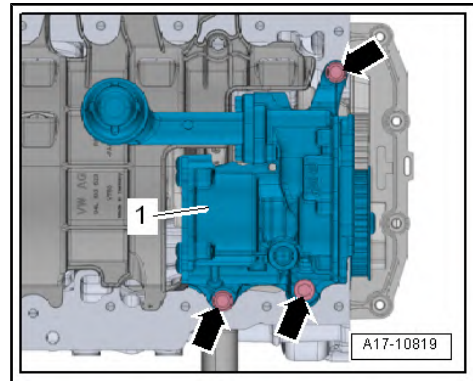

### Installation

Installation is carried out in the reverse order; note the following:



#### Note

- ◆ *Seal must be renewed if removed*
- ◆ *Renew bolts that are tightened with turning further angle after each removal.*
- Insert dowel sleeves -arrows- in oil pump, if not fitted.
- Install sump ⇒ [page 161](#) .

### Specified torques

- ◆ ⇒ [“1.1 Exploded view - sump/oil pump”, page 159](#)

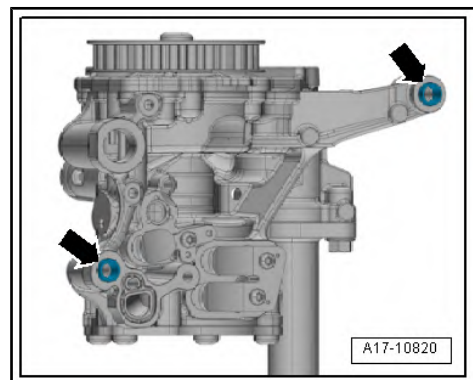

## 1.5 Removing and installing oil level and oil temperature sender - G266-

### Removal

- Engine oil drained ⇒ Maintenance ; Booklet 501
- Unplug electrical connector -arrow- at oil level and oil temperature sender - G266- .

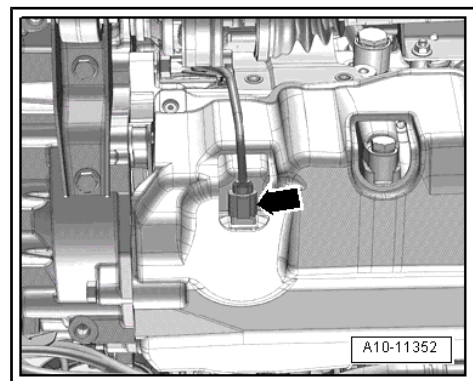

- Release fasteners -arrows- and detach noise insulation -1- for sump.

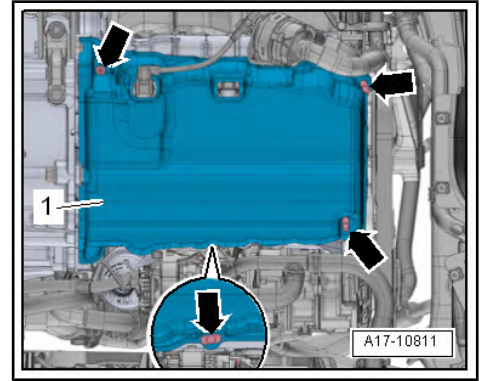

- Remove bolts -1- and detach oil level and oil temperature sender - G266- -item 4-.

 **Note**

*Item -3- can be disregarded.*

**Installation**

Installation is carried out in the reverse order; note the following:

 **Note**

*Renew seal -2- and self-locking bolts -1-.*

- Fill with engine oil and check oil level ⇒ Maintenance ; Booklet 501 .

**Specified torques**

- ◆ ⇒ [“1.1 Exploded view - sump/oil pump”, page 159](#)

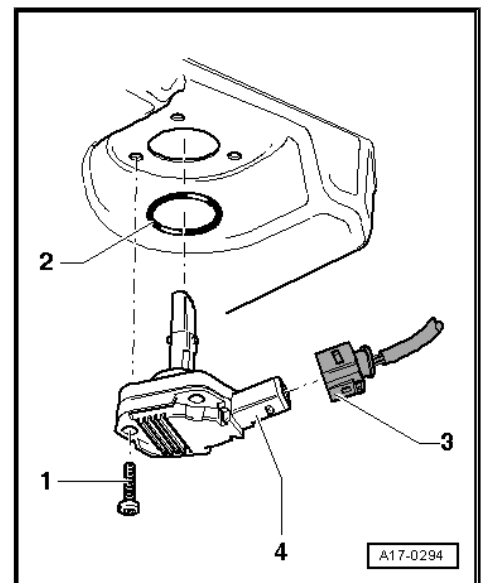

## 2 Engine oil radiator



### Note

*Engine oil cooler must not be separated from oil filter housing. If defective, engine oil cooler must be renewed together with oil filter housing ⇒ [page 172](#) .*

### 3 Oil filter, oil pressure switch

⇒ [“3.1 Exploded view - oil filter housing/oil pressure switches”, page 169](#)

⇒ [“3.2 Removing and installing oil pressure switch F1”, page 170](#)

⇒ [“3.3 Removing and installing oil pressure switch for reduced oil pressure F378”, page 171](#)

⇒ [“3.4 Checking oil pressure”, page 172](#)

⇒ [“3.5 Removing and installing oil filter housing”, page 172](#)

⇒ [“3.6 Removing and installing valve for oil pressure control N428”, page 174](#)

#### 3.1 Exploded view - oil filter housing/oil pressure switches

##### 1 - Oil drain plug

- 5 Nm

##### 2 - O-ring

- Renew following removal

##### 3 - Sealing cap

- 25 Nm

##### 4 - O-ring

- Renew following removal
- Lubricate lightly with engine oil

##### 5 - Oil filter cartridge

- See note ⇒ [page 159](#) .
- Remove and install ⇒ Maintenance ; Booklet 501 .

##### 6 - Oil seal

- Renew following removal

##### 7 - Oil pressure switch - F1-

- Opening/closing pressure 2.5 ... 3.2 bar
- Brown insulation
- Checking in [Guided Fault Finding](#) ⇒ Vehicle diagnostic tester
- Removing and fitting ⇒ [page 170](#)
- 20 Nm

##### 8 - Bolt.

- Renew following removal
- Tightening torque and sequence ⇒ [page 170](#) .

##### 9 - Oil filter housing

- With integrated oil retention valve
- Removing and fitting ⇒ [page 172](#)

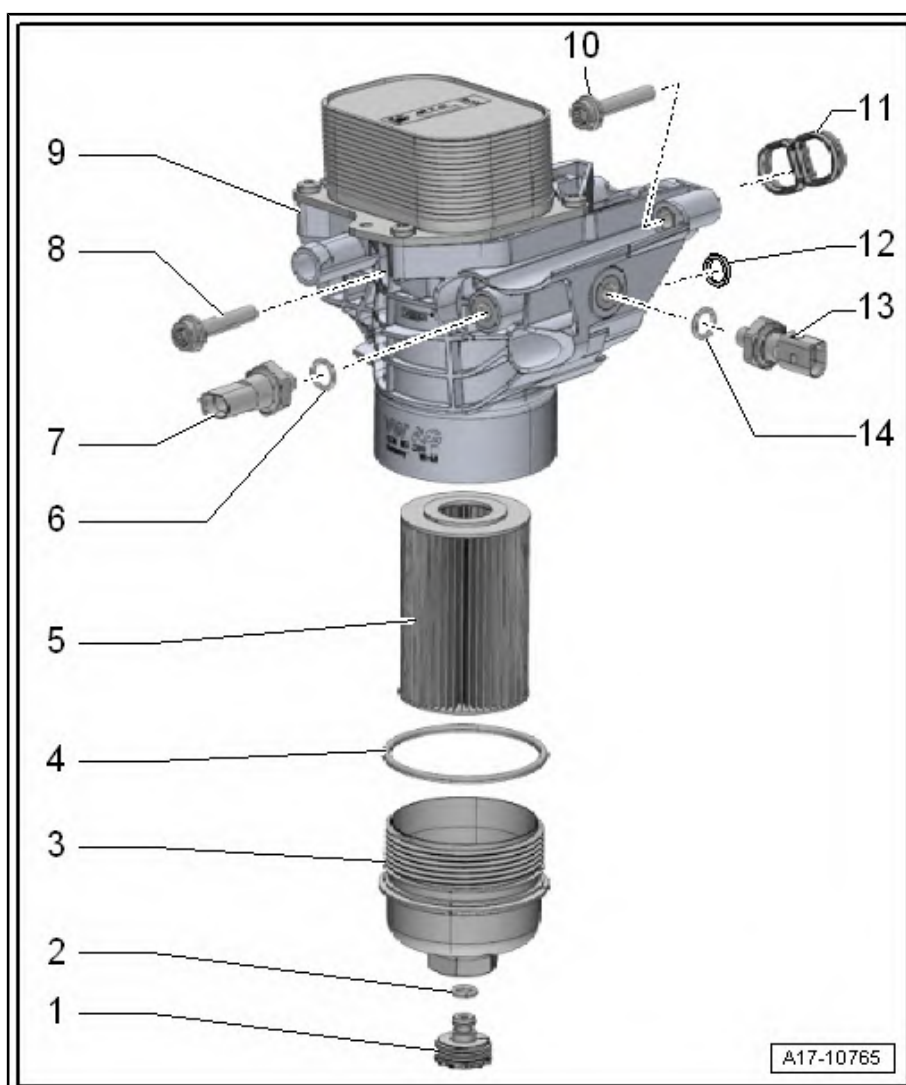

### 10 - Bolt.

- Renew following removal
- Tightening torque and sequence ⇒ [page 170](#) .

### 11 - Seal

- Renew following removal

### 12 - Oil seal

- Renew following removal

### 13 - Oil pressure switch for reduced oil pressure - F378-

- Opening/closing pressure 0.3 ... 0.6 bar
- Green insulation
- Checking in Guided Fault Finding ⇒ Vehicle diagnostic tester
- Removing and fitting ⇒ [page 171](#)
- 20 Nm

### 14 - O-ring

- Captive. In the event of leaks, renew oil pressure switch.

### Oil filter housing - tightening torque and sequence

#### Note

*Renew bolts that are tightened with turning further angle after each removal.*

- Fit bolts at top left and bottom right first.
- Tighten bolts in stages in the sequence shown:

stage	Bolts	Tightening torque/angle specification
1st	-1 ... 5-	20 Nm
2nd	-1 ... 5-	Turn 90° further

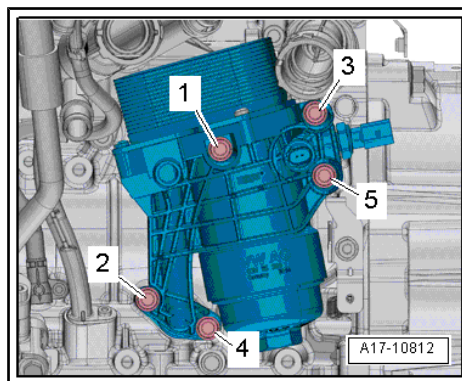

## 3.2 Removing and installing oil pressure switch - F1-

### Removal

- Remove engine cover. ⇒ [page 56](#)
- Free coolant hose -3-.
- Remove screws -1-.
- Release locking lugs-arrow-, unclip air hose -2- from the front end and remove in -direction of the arrow-.

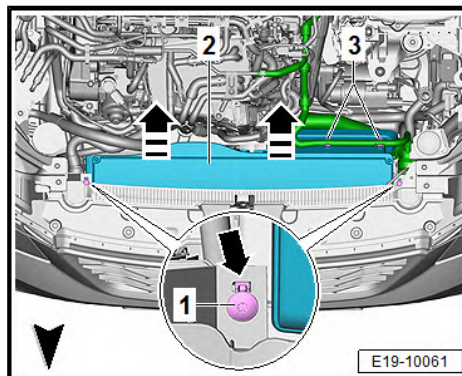

- Disconnect electrical connector -arrow-.

 **Note**

*Place a cloth underneath to catch escaping engine oil.*

- Remove the oil pressure switch - F1- .

**Installation**

Installation is carried out in the reverse order; note the following:

 **Note**

*After removal, renew the oil pressure switch.*

- Install engine cover panel ⇒ [page 56](#) .
- check oil level⇒ Maintenance ; Booklet 501 .

**Specified torques**

- ◆ ⇒ [“3.1 Exploded view - oil filter housing/oil pressure switches”, page 169](#)
- ◆ ⇒ [“4.1 Exploded view - air cleaner housing”, page 319](#)

### 3.3 Removing and installing oil pressure switch for reduced oil pressure - F378-

**Special tools and workshop equipment required**

- ◆ 24 mm jointed spanner - T40175-

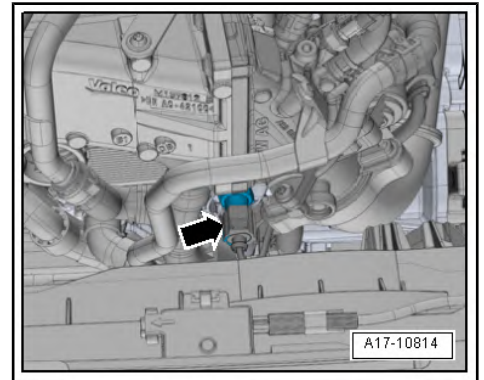

## Removal

- Remove air cleaner housing ⇒ [page 320](#) .
- Disconnect electrical connector -arrow-



### Note

*Place a cloth underneath to catch escaping engine oil.*

- Use articulated wrench, 24 mm - F378- to remove oil pressure switch for reduced oil pressure - T40175- .

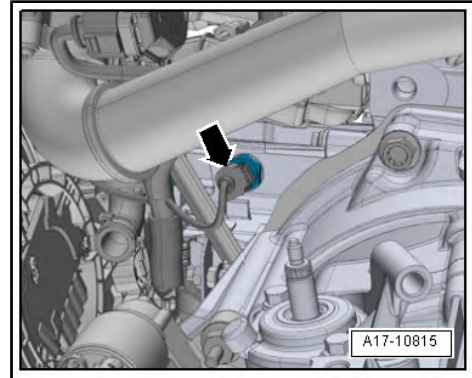

## Installation

Installation is carried out in the reverse order; note the following:



### Note

*After removal, renew the oil pressure switch.*

- check oil level⇒ Maintenance ; Booklet 501 .

## Specified torques

- ◆ ⇒ [“3.1 Exploded view - oil filter housing/oil pressure switches”](#), [page 169](#)
- ◆ ⇒ [“4.1 Exploded view - air cleaner housing”](#), [page 319](#)

## 3.4 Checking oil pressure



### Note

*Due to the clutch speed protection system it is not possible to select all stages of the oil pressure control when the vehicle is stationary. For this reason, check the oil pressure with the vehicle diagnostic and service information system .*

- Connect vehicle diagnostic tester .
- Check oil pressure. To do this, use a vehicle diagnostic and service information system , [checking oil](#).

## 3.5 Removing and installing oil filter housing

### Special tools and workshop equipment required

- ◆ Hose clip pliers - VAS 6362-



## Removal

- Remove radiator cowl ⇒ [page 244](#) .

- Remove coolant pipe (front left) ⇒ [page 212](#) .
- Remove coolant pipe (front right) ⇒ [page 214](#) .
- Loosen hose clips -arrows- and remove air hoses.

 **Note**

*Ignore -item 1-.*

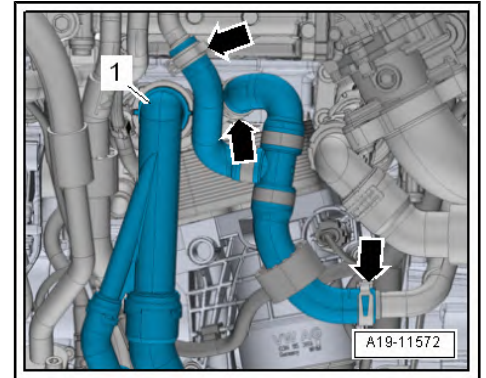

- Unplug the electrical connector -2-.
- Unscrew bolt -1- and push the pump to the side for the charge air cooler - V188- -item 3-.

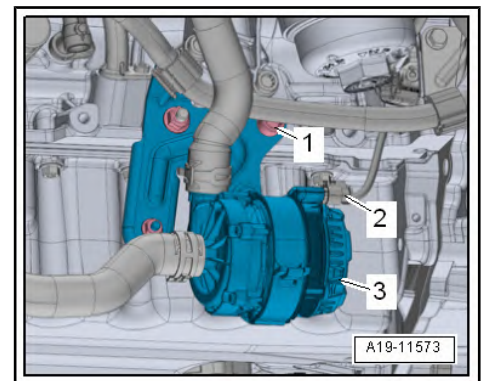

- Unplug electrical connector -1- at valve for oil pressure control - N428- .

 **Note**

*Item -2- can be disregarded.*

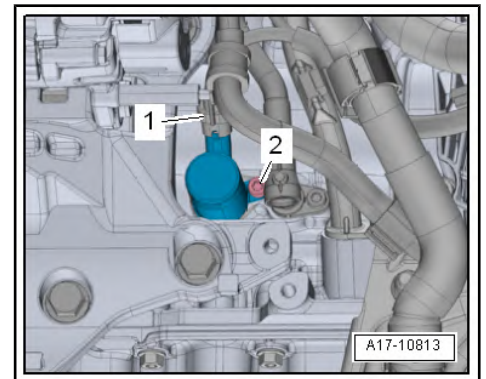

- Unplug the electrical connector -arrow- on the oil pressure switch - F1- .

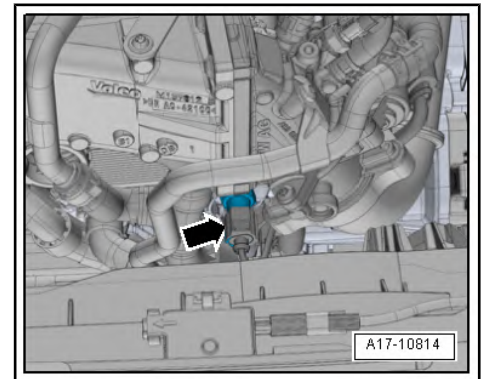

- Unplug electrical connector -arrow- at oil pressure switch for reduced oil pressure - F378- .

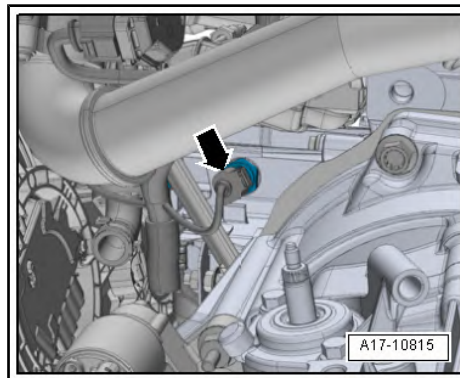

**i** Note

Place a cloth underneath to catch escaping engine oil.

- Unscrew bolts in the sequence -5 ... 1- and detach oil filter housing together with engine oil cooler.

**Installation**

Installation is carried out in the reverse order; note the following:

**i** Note

- ◆ Renew seal and O-ring after removal.
- ◆ Secure all hose connections with the correct type of hose clips (same as original equipment) ⇒ *Electronic parts catalogue* .

- Install coolant pipe (front right) ⇒ [page 214](#) .
- Install coolant pipe (front left) ⇒ [page 212](#) .
- Install radiator cowl ⇒ [page 244](#) .
- Connect coolant hose with plug-in connector ⇒ [page 228](#) .
- Replenish coolant ⇒ [page 184](#) .

**Specified torques**

- ◆ ⇒ [“3.1 Exploded view - oil filter housing/oil pressure switches”, page 169](#)
- ◆ ⇒ [“2.2 Exploded view - electric coolant pump”, page 190](#)
- ◆ ⇒ [“4.1 Exploded view - air cleaner housing”, page 319](#)

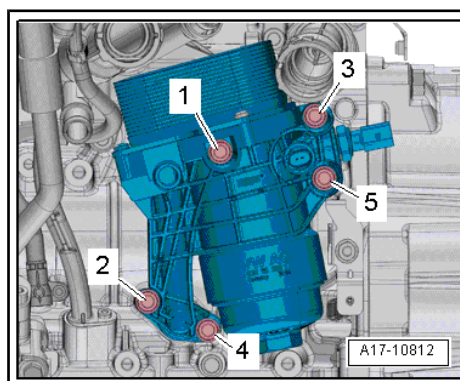

### 3.6 Removing and installing valve for oil pressure control - N428-

**Removal**

- Remove the poly V-belt ⇒ [page 59](#) .
- Remove the A/C compressor with connected refrigerant hoses from the bracket ⇒ Rep. gr. 87 ; A/C compressor; Attaching/ detaching the A/C compressor to/from the bracket and tie it up to the right.

- Unplug the electrical connector -1-.

 **Note**

*Place a cloth underneath to catch escaping engine oil.*

- Unscrew bolt -2- and remove valve for oil pressure control - N428- .

**Installation**

Installation is carried out in the reverse order; note the following:

 **Note**

*Renew O-ring.*

- Fit poly V-belt ⇒ [page 59](#) .
- check oil level⇒ Maintenance ; Booklet 501 .

**Specified torques**

- ◆ ⇒ [“1.1 Exploded view - sump/oil pump”, page 159](#)
- ◆ Assembly overview - drive unit of the air conditioner compressor ⇒ Rep. gr. 87 ; Air conditioner compressor; Assembly overview - drive unit of air conditioner compressor

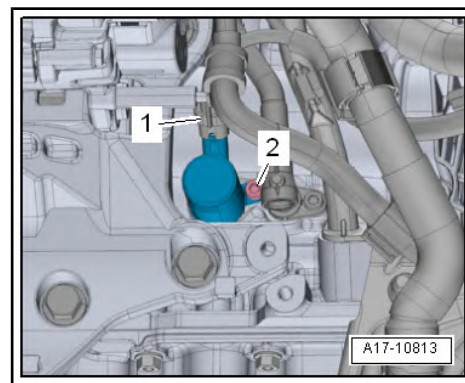

## 19 – Cooling

### 1 Cooling system/coolant

⇒ [“1.1 Connection diagram - coolant hoses”, page 176](#)

⇒ [“1.2 Checking cooling system for leaks”, page 179](#)

⇒ [“1.3 Draining and filling coolant”, page 181](#)

#### 1.1 Connection diagram - coolant hoses

⇒ [“1.1.1 Connection diagram - coolant hoses”, page 176](#)

⇒ [“1.1.2 Connection diagram – coolant hose, vehicles with actuator for exhaust gas recirculation V338”, page 178](#)

##### 1.1.1 Connection diagram - coolant hoses



#### Note

- ◆ *Light grey = large cooling circuit.*
- ◆ *Green = small coolant circuit.*
- ◆ *Dark grey = charge air cooler coolant circuit.*
- ◆ *Arrows show direction of coolant flow.*

**1 - Water radiator for charge air cooling circuit**

- Change coolant after re-newing.

**2 - Intercooler system**

- Change coolant after re-newing.

**3 - Non-return valve**

**4 - Coolant pump**

**5 - Cylinder head/cylinder block**

- Change coolant after re-newing.

**6 - Coolant expansion tank**

**7 - Sealing cap**

- For coolant expansion tank
- Checking pressure relief valve ⇒ [page 181](#)

**8 - Auxiliary pump for heating - V488-**

**9 - Non-return valve**

**10 - Non-return valve**

**11 - Heat exchanger for heater**

- Renew coolant after re-newing

**12 - Exhaust gas recirculation cooler**

- Change coolant after re-newing.

**13 - Non-return valve**

**14 - Coolant temperature sensor - G62-**

**15 - Non-return valve**

**16 - Coolant hose/pipe connection**

**17 - Thermostat**

**18 - Engine oil radiator**

**19 - Non-return valve**

**20 - Coolant radiator**

- Change coolant after re-newing.

**21 - Throttle valve control mechanism - J338-**

**22 - Charge air cooling pump - V188-**

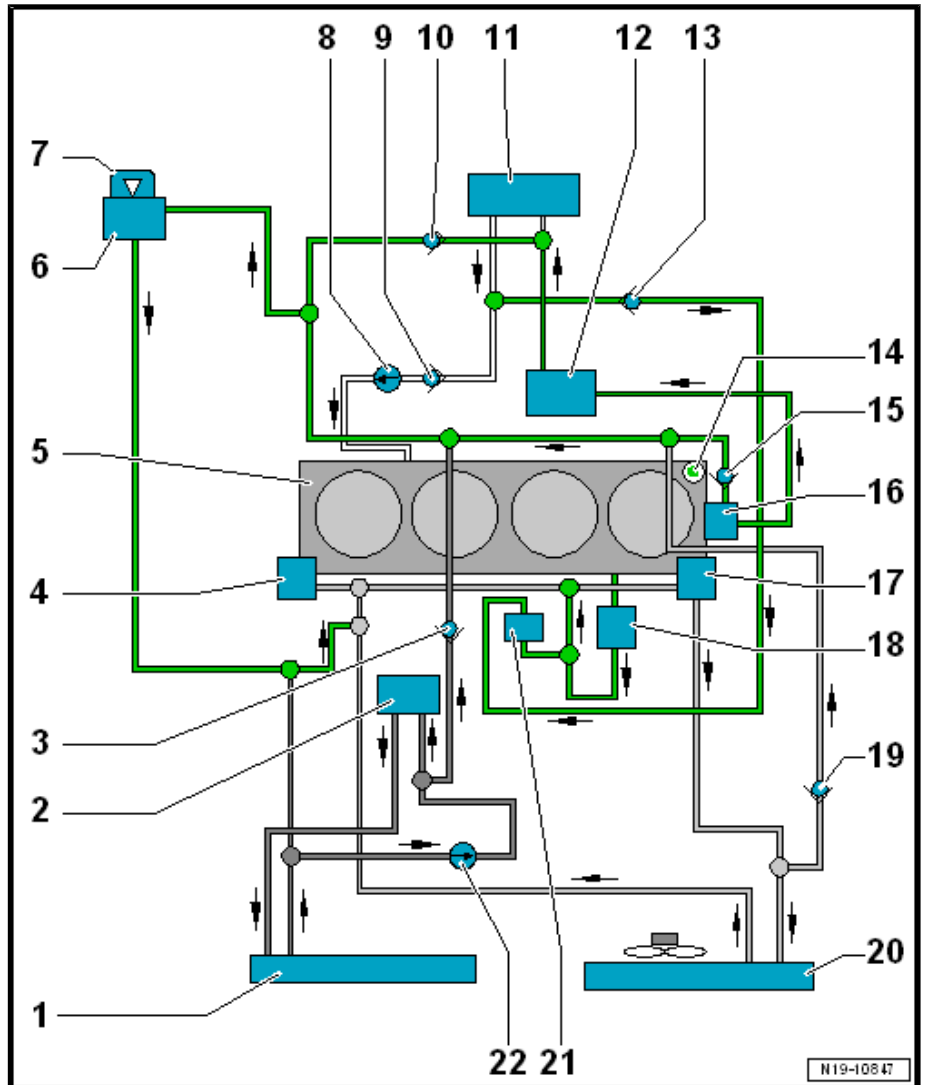

## 1.1.2 Connection diagram – coolant hose, vehicles with actuator for exhaust gas recirculation - V338-

### Note

- ◆ Blue = Large coolant circuit.
- ◆ Red = Small coolant circuit.
- ◆ Purple = charge air cooler coolant circuit.
- ◆ Brown = Heating circuit.
- ◆ Arrows show direction of coolant flow.

#### 1 - Radiator for charge air cooling circuit

- Renew coolant after re-newing

#### 2 - Intercooler system

- Renew coolant after re-newing

#### 3 - Non-return valve

#### 4 - Coolant pump

#### 5 - Cylinder head/cylinder block

- Renew coolant after re-newing

#### 6 - Coolant expansion tank

#### 7 - Sealing plug

- For coolant expansion tank
- Checking pressure relief valve ⇒ [page 181](#)

#### 8 - Auxiliary pump for heating - V488-

#### 9 - Non-return valve

#### 10 - Non-return valve

- Depending on equipment.

#### 11 - Heat exchanger for heater

- Renew coolant after re-newing

#### 12 - Exhaust gas recirculation cooler

- Renew coolant after re-newing

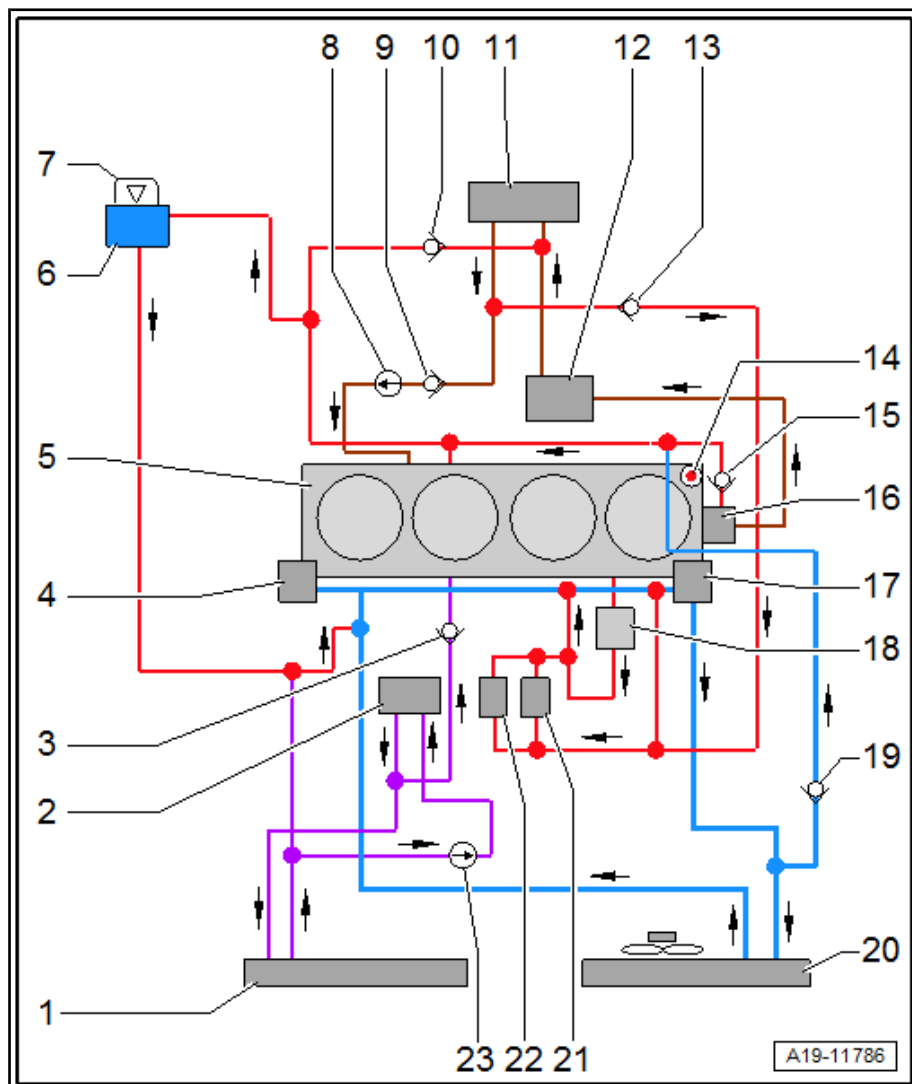

- 13 - Non-return valve
- 14 - Coolant temperature sensor - G62-
- 15 - Non-return valve
- 16 - Coolant hose/pipe connection
- 17 - Thermostat
- 18 - Engine oil radiator
- 19 - Non-return valve
- 20 - Radiator
  - Renew coolant after renewing
- 21 - Throttle valve control mechanism - J338-
- 22 - Exhaust gas recirculation control motor - V338-
- 23 - Charge air cooling pump - V188-

## 1.2 Checking cooling system for leaks

Special tools and workshop equipment required

- ◆ Cooling system tester - V.A.G 1274 B-

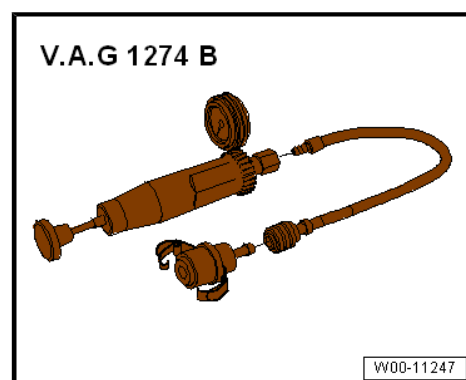

- ◆ Adapter for cooling system tester - V.A.G 1274/8-



◆ Adapter for cooling system tester - V.A.G 1274/9-

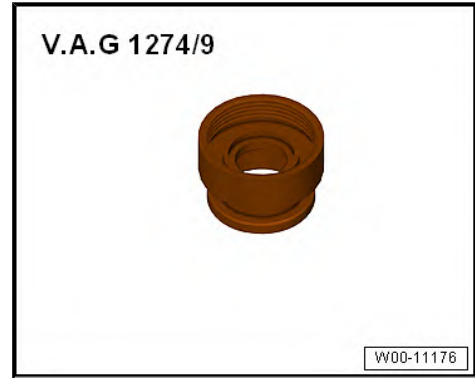

**Note**

*In order to correctly perform a leakage test, first the cooling system tester - V.A.G 1274 B- must be inspected (self test)!*

**Self test of cooling system tester - V.A.G 1274 B-**

- Operate cooling system tester - V.A.G 1274 B- several times.

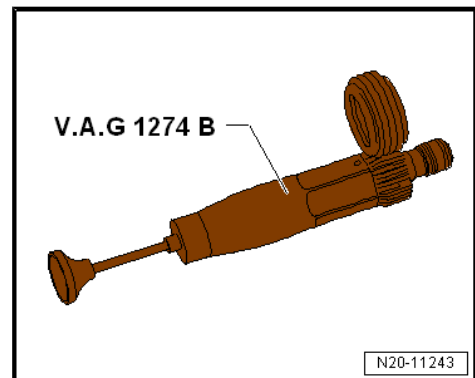

- Build up a pressure of 3.0 bar on cooling system tester .
- Observe pressure on pressure gauge of cooling system tester for 30 seconds.

**If no pressure builds up or if the pressure drops again:**

There is a leak in the cooling system tester - V.A.G 1274 B- , and it must not be used.

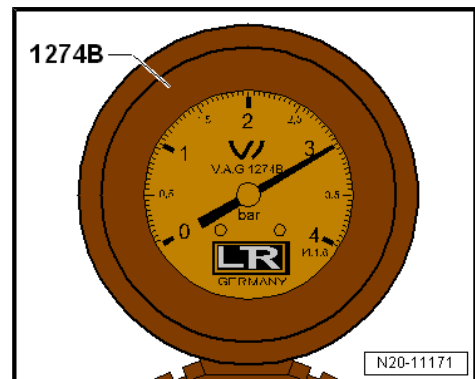

**Check the cooling system for leaks**

- Engine at operating temperature.

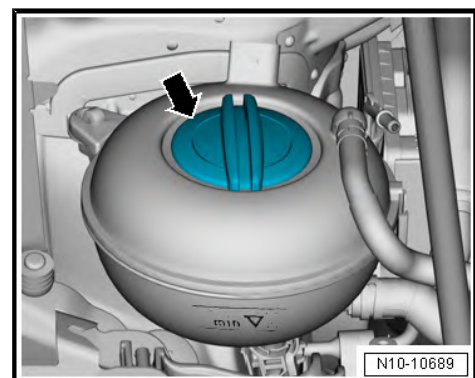

### Risk of scalding by hot coolant.

The cooling system is under pressure when the engine is hot. Hot coolant and vapours can cause burns!

- Wear protection gloves.
- Use safety goggles.
- Reduce pressure: Place a cloth over the cover plate of the coolant expansion tank and open carefully.
  
- Open cap -arrow- on coolant expansion tank.
- Fit cooling system tester - V.A.G 1274 B- with adapter - V.A.G 1274/8- onto coolant expansion tank.
- Using hand pump on cooling system tester, build up a pressure of approx. 1.5 bar.
- The pressure must not drop by more than 0.2 bar within 10 minutes.
- If pressure drops by more than 0.2 bar, locate leaks and rectify faults.

#### Note

*The pressure drop by more than 0.2 bar within 10 minutes is caused by the coolant which cools down. The colder the engine, the lower the pressure loss. If necessary, repeat the check while the engine is cold.*

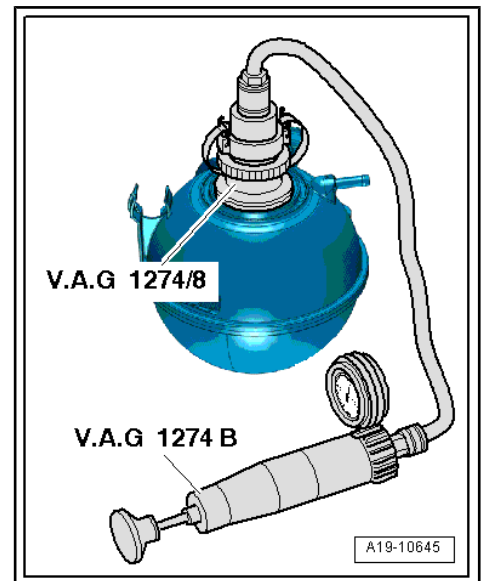

### Testing pressure relief valve in filler cap

- Fit cooling system tester - V.A.G 1274 B- with adapter - V.A.G 1274/9- onto filler cap.
- Build up pressure with hand pump on cooling system tester.
- The pressure relief valve should open at a pressure of 1.6 ... 1.8 bar.
- Renew filler cap if pressure relief valve does not open as described.

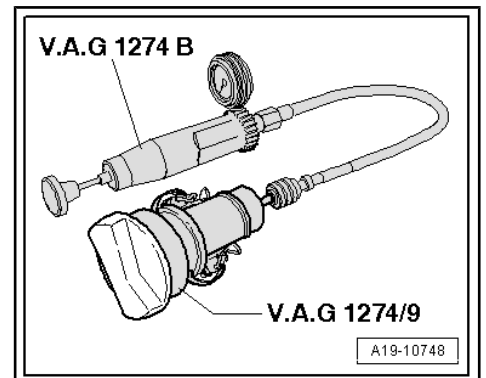

## 1.3 Draining and filling coolant

Special tools and workshop equipment required

- ◆ Refractometer - T10007A-

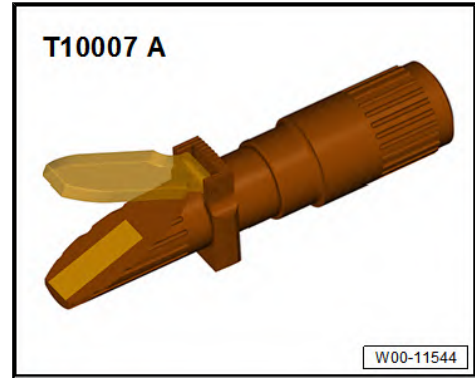

- ◆ Hose clip pliers - VAS 6340-

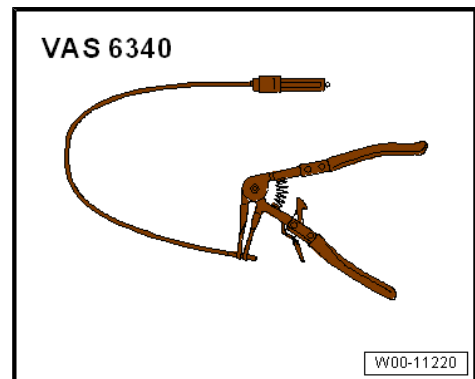

- ◆ Drip tray for workshop hoist - VAS 6208-



- ◆ Cooling system charge unit - VAS 6096-

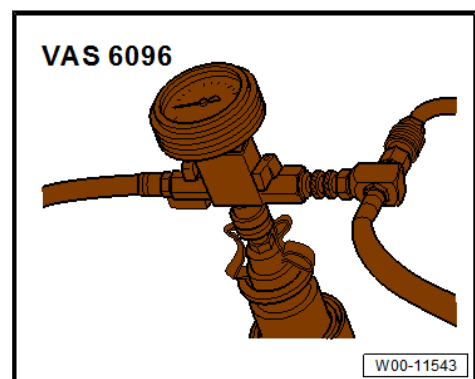

- ◆ Adapter for cooling system tester - V.A.G 1274/8-

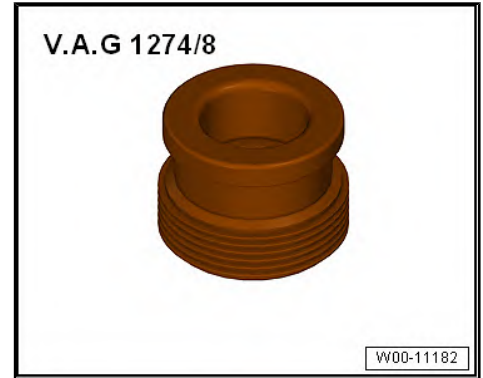

- ◆ Protective glasses
- ◆ Protective gloves

#### Draining off

 **WARNING**

*When the engine is warm the cooling system is under pressure.  
 Hot coolant and vapours can cause burns!*

*Cover filler cap on expansion tank with a cloth and open carefully to dissipate pressure.*

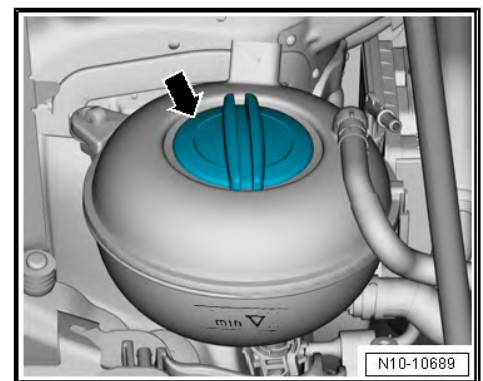

- Open cap -arrow- on coolant expansion tank.
- Remove noise insulation => General body repairs, exterior; Rep. gr. 66 ; Noise insulation; Assembly overview - noise insulation .
- Place drip tray for workshop hoist - VAS 6208- underneath.

#### Radiator, version 1:

- Lift the retaining clip -arrow-, remove the coolant hose at the bottom left from the radiator, allow the coolant to drain off.

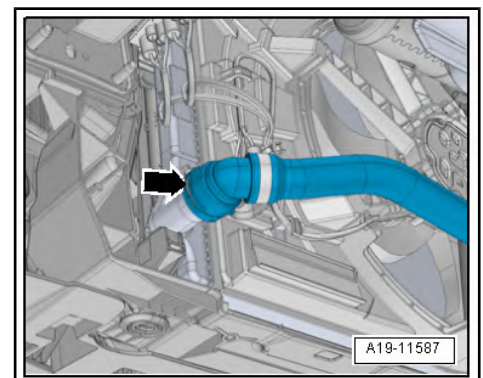

- Lift the retaining clip -arrow-, remove the coolant hose at the bottom right from the water radiator for the charge air cooling circuit, allow the coolant to drain off.

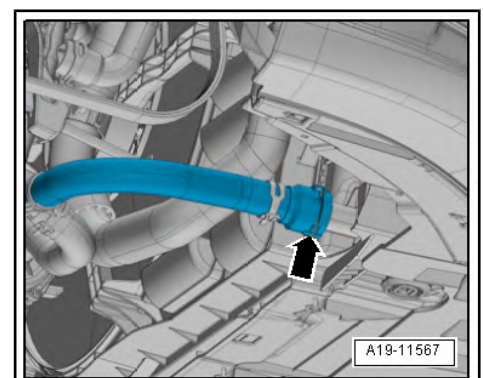

### Radiator, version 2:

- Lift the retaining clip -1-, remove the coolant hose at the bottom right from the radiator, allow the coolant to drain off.
- Lift the retaining clip -2-, remove the coolant hose at the bottom right from the water radiator for the charge air cooling circuit, allow the coolant to drain off.

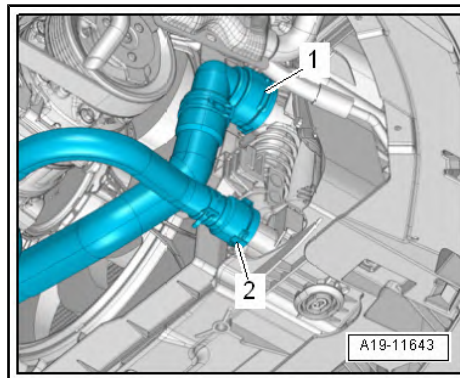

### Radiator, version 3:

- Lift the retaining clip -arrow-, remove the coolant hose at the bottom left from the radiator, allow the coolant to drain off.

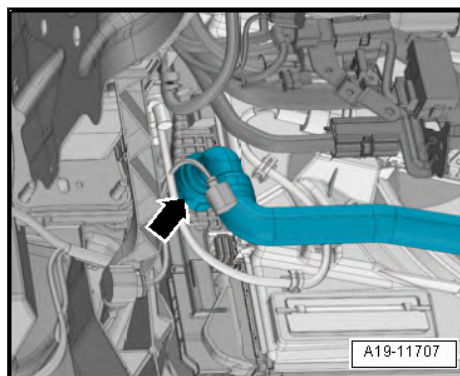

- Lift the retaining clips -1, 2-, remove the coolant hoses from the water radiator for the charge air cooling circuit, allow the coolant to drain off.

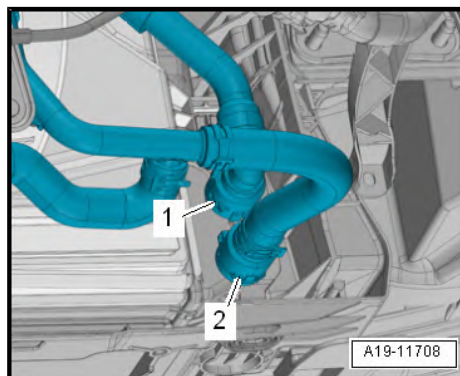

### All vehicles (continued):

- Loosen hose clip -arrow-.
- Remove lower coolant hose to auxiliary pump for heating - V488- .
- Drain off coolant.

### Filling



#### Caution

**Risk of damage to the engine due to insufficiently filled/bled cooling system.**

- ◆ **After filling, the cooling system must be bled ⇒ Vehicle diagnostic tester without fail.**

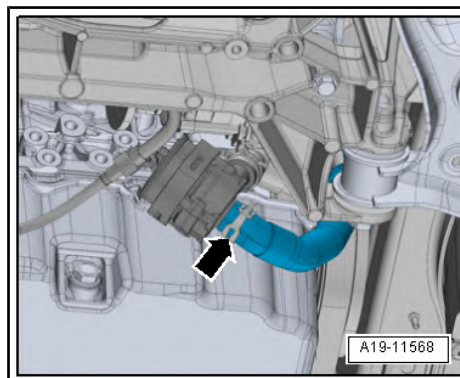



## Note

- ◆ *The water used for the mixtures heavily influences the effectiveness of the coolant. The quality of water to be used is specified since the ingredients can vary from one land or region to another. Distilled water fulfils all requirements. Therefore, the coolant must be mixed with distilled water when filling and refilling.*
- ◆ *Use only the coolant additives listed in the ⇒ Electronic parts catalogue (ETKA) . Other coolant additives may reduce corrosion protection substantially. Resulting damages may cause coolant loss and may lead to heavy engine damages.*
- ◆ *Mixed in the proper proportions, coolant inhibits frost and corrosion damage as well as calcium deposits. Such additives also raise the boiling point of the coolant. For this reason the cooling system must be filled all year round with the correct coolant additive.*
- ◆ *Because of its high boiling point, the coolant improves engine reliability under heavy loads, particularly in countries with tropical climates.*
- ◆ *ONLY refractometer - T10007A- may be used for determining current anti-freeze value.*
- ◆ *The frost protection must be effective down to at least -25 °C, and approx. -36 °C in cold countries. The effectiveness of the frost protection may only be increased if a higher level of frost protection is required due to the climate. But only down to -48 °C, otherwise the cooling effect of the coolant gets worse.*
- ◆ *The coolant concentration must not be reduced by adding water even in warmer seasons and in warmer countries. The frost protection must be at least -25 °C.*
- ◆ *Read the frost protection value on the scale of the respective refilled coolant additive*
- ◆ *The temperature read off the refractometer - T10007A- equates to the »ice flocculation point«. Ice flocculation can start forming in the coolant below this temperature.*
- ◆ *Do not re-use used coolant.*
- ◆ *Use only a water/anti-freeze mixture as a slip agent for coolant hoses.*

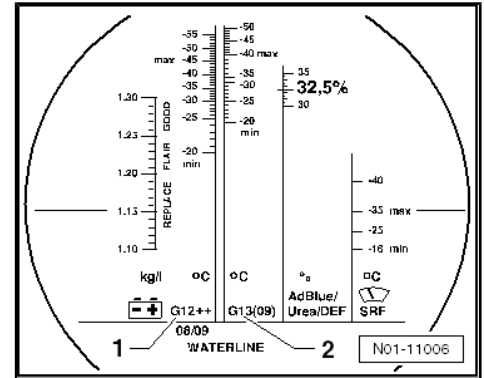

## Recommended mixture ratio for coolant

- Coolant additive (40 %) and water (60 %) for frost protection to -25 °C
- Coolant additive (50 %) and water (50 %) for frost protection to -36 °C
- Additive for coolant: ⇒ Electronic parts catalogue

## Procedure

- Reconnect coolant hoses with plug-in connectors  
⇒ [page 228](#) .
- Reconnect coolant hoses with hose clips to electric coolant pumps.

- Fill reservoir of -VAS 6096- with at least 8 litres of pre-mixed coolant in correct mixture ratio:
- Screw down adapter for cooling system tester - V.A.G 1274/8- to coolant expansion tank.
- Attach cooling system charge unit - VAS 6096- to adapter - V.A.G 1274/8- .
- Run vent hose -1- into a small container -2-.



**Note**

*Exhaust air takes a slight quantity of coolant along with it; this should be collected.*

- Close both valves -A- and -B- (turn lever at right angles to direction of flow).
- Connect hose -3- to compressed air.
- 6 ... 10 bar of working pressure.
- Open valve -B- by setting lever in direction of flow.
- The suction jet pump generates a vacuum in the cooling system.
- The display instrument needle must move to the green area.
- In addition, briefly open valve -A- (turn lever in direction of flow to do this) so that hose on -VAS 6096- reservoir fills with coolant.
- Close the valve -A- again.
- Leave valve -B- open for 2 further minutes.
- The suction jet pump will continue generating a vacuum in the cooling system. The pointer of the indicator must remain in the green zone.
- Close valve -B-.
- The needle on the gauge must stay in the green zone. Then the vacuum in the cooling system is sufficient for the subsequent filling.



**Note**

- ◆ *If the needle does not reach the green zone, repeat the process.*
- ◆ *If the vacuum drops, check the cooling system for leaks.*
- Pull off compressed air hose.
- Open valve -A-.
- The partial vacuum in cooling system causes coolant to be extracted from -VAS 6096- reservoir and coolant system to be filled.
- Detach cooling system charge unit - VAS 6096- from coolant expansion tank.

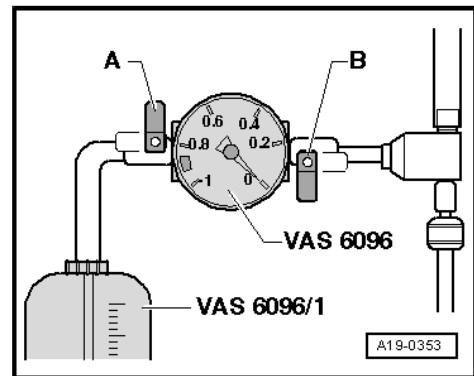
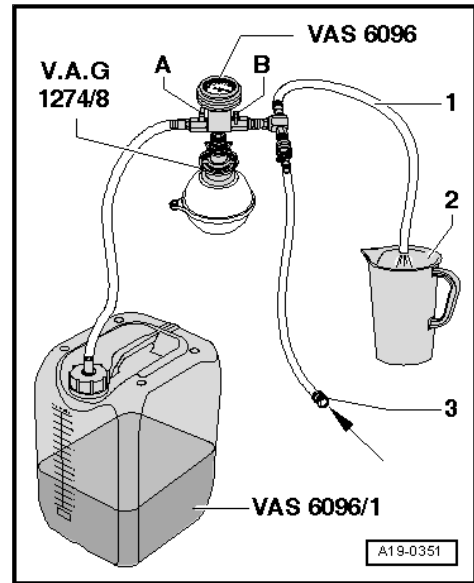

- Fill coolant up to max. mark.

 **Note**

*Hose unions and air intake pipes/hoses must be free of oil and grease when installing.*

- Install noise dampers ⇒ General body repairs, exterior; Rep. gr. 66 ; Noise insulation; Assembly overview - Noise insulation .
- On vehicles with auxiliary heater, switch heater on (for about 30 seconds) and then off again.
- Set temperature to "HI".
- Switch off air conditioner compressor. To do this, press **AC** button.
- LED in button should not light up.
- Connect vehicle diagnostic tester .
- Switch on the ignition and, in the vehicle diagnostics tester , select the following menu items:
  - ◆ **Self-diagnosis-capable systems**
  - ◆ **0001 - Engine electronics**
  - ◆ **0001 - Engine electronics, functions**
  - ◆ **0001 - Filling cooling circuit**
- Follow instructions on vehicle diagnosis and service information system .
- Check coolant level.

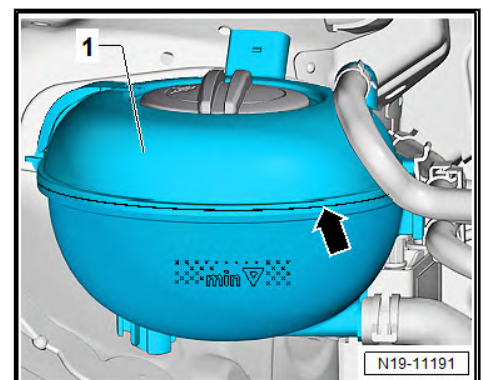
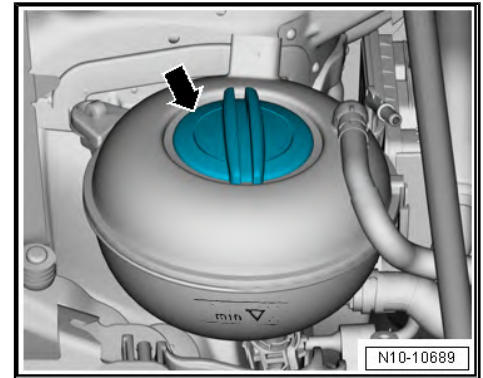

- When the engine is at operating temperature, the coolant level must not be above the »weld seam« -arrow-.
- When the engine is cold, the coolant level must be approx. 5 mm -arrow- above max. marking.

 **Note**

*This top coolant level is required because it may fall further during ventilation.*

- Top up with coolant if necessary.

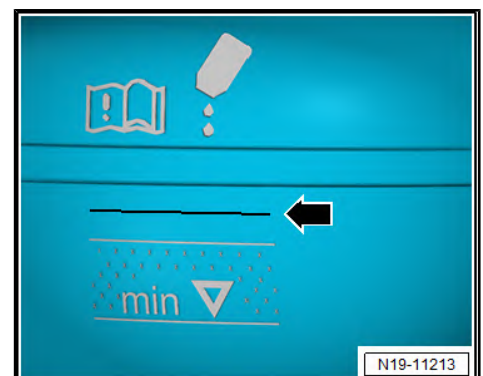

## 2 Coolant pump/coolant thermostat

⇒ ["2.1 Exploded view - coolant pump and thermostat", page 188](#)

⇒ ["2.2 Exploded view - electric coolant pump", page 190](#)

⇒ ["2.3 Exploded view - coolant temperature sensors", page 194](#)

⇒ ["2.4 Removing and installing electric coolant pump", page 194](#)

⇒ ["2.5 Removing and replacing coolant pump", page 203](#)

⇒ ["2.6 Cooling system thermostat: removing and installing", page 204](#)

⇒ ["2.7 Testing coolant thermostat", page 205](#)

⇒ ["2.8 Removing and installing coolant valve for cylinder head N489", page 206](#)

⇒ ["2.9 Removing and installing coolant temperature sender G62", page 206](#)

### 2.1 Exploded view - coolant pump and thermostat

#### 1 - O-rings

- Renew following removal
- Lubricate with coolant

#### 2 - Connection

#### 3 - O-ring

- Renew following removal
- Lubricate with coolant

#### 4 - Coolant pipe (bottom front)

- Removing and fitting  
⇒ [page 210](#)

#### 5 - Oil seal

- Renew following removal

#### 6 - O-ring

- Renew following removal
- Lubricate with coolant

#### 7 - Coolant pump

- Removing and fitting  
⇒ [page 203](#)

#### 8 - O-rings

- Renew following removal
- Lubricate with coolant

#### 9 - Bolt.

- 8 Nm

#### 10 - Valve for the cylinder head coolant - N489-

- Removing and fitting ⇒ [page 206](#)

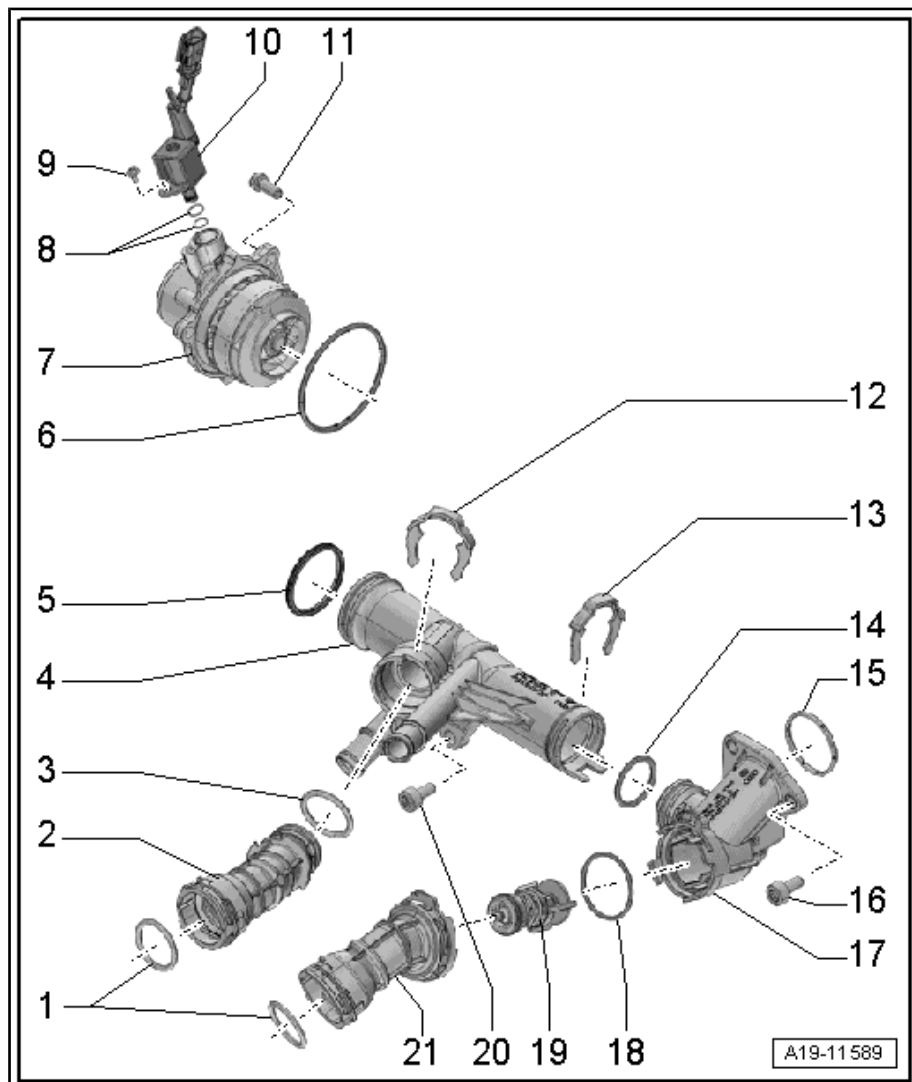

**11 - Bolt.**

- Renew following removal
- 20 Nm + turn +45° further

**12 - Staple**

- Check for secure seating.

**13 - Retaining clip**

- Check for secure seating.

**14 - O-ring**

- Renew following removal
- Lubricate with coolant

**15 - Oil seal**

- Renew following removal

**16 - Bolt.**

- 20 Nm

**17 - Thermostat housing**

**18 - O-ring**

- Renew following removal
- Lubricate with coolant

**19 - Thermostat**

- Removing and fitting ⇒ [page 204](#)

**20 - Bolt.**

- 20 Nm

**21 - Connection**

## 2.2 Exploded view - electric coolant pump

⇒ [“2.2.1 Assembly overview - charge air cooling pump V188 and auxiliary pump for heating V488 , version 1”](#), page 190

⇒ [“2.2.2 Assembly overview - charge air cooling pump V188 , version 2”](#), page 191

⇒ [“2.2.3 Assembly overview - auxiliary pump for heating V488 , version 2”](#), page 192

⇒ [“2.2.4 Assembly overview - charge air cooling pump V188 , version 3”](#), page 193

### 2.2.1 Assembly overview - charge air cooling pump - V188- and auxiliary pump for heating - V488- , version 1

#### 1 - Charge air cooling pump - V188-

- Removing and fitting  
⇒ [page 194](#)

#### 2 - Coolant hose

#### 3 - Coolant hose

#### 4 - Bolt.

- 40 Nm

#### 5 - Bolt.

- 40 Nm

#### 6 - Auxiliary pump for heating - V488-

- Removing and fitting  
⇒ [page 196](#)

#### 7 - Coolant hose

#### 8 - Coolant hose

#### 9 - Bracket/bearing/support

- For auxiliary pump for heating - V488-

#### 10 - Retaining clips

#### 11 - Bolt.

- 40 Nm

#### 12 - Bracket/bearing/support

- For charge air cooling pump - V188-

#### 13 - Retaining clips

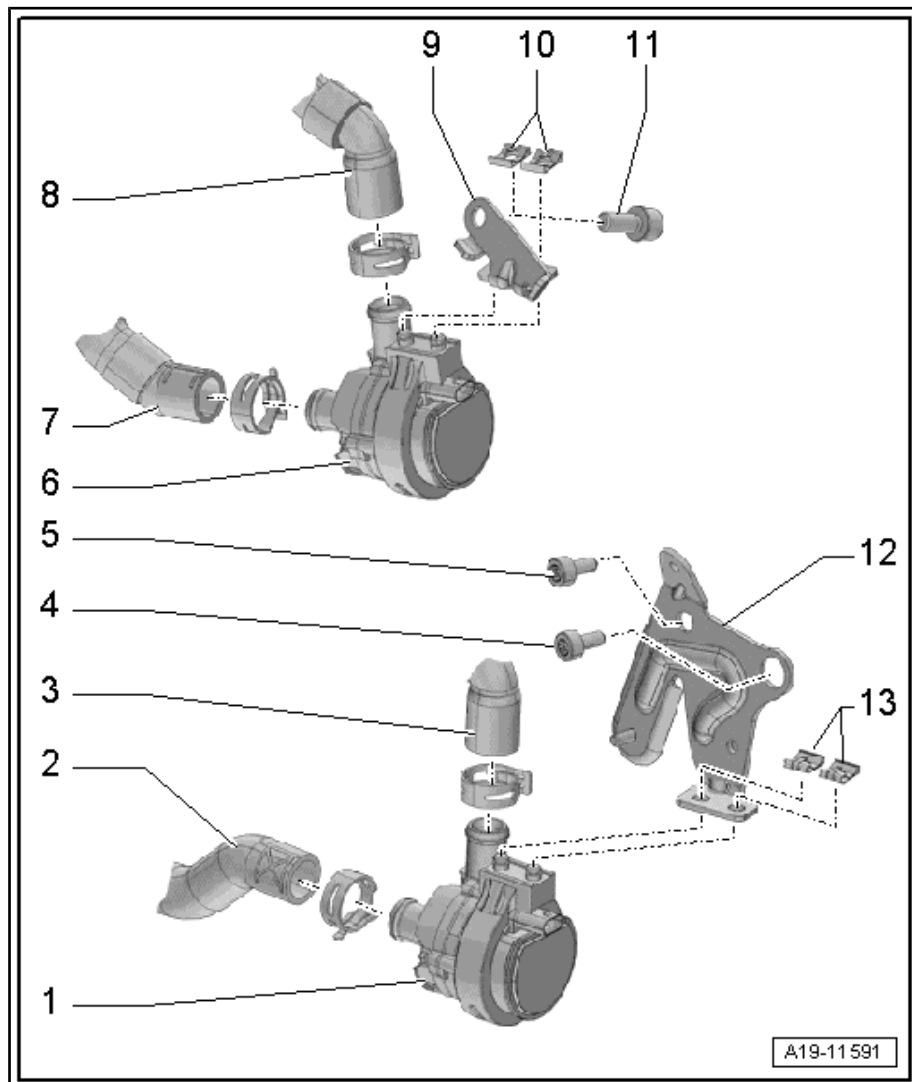

## 2.2.2 Assembly overview - charge air cooling pump - V188- , version 2

1 - Retaining clip

2 - Bolt.

□ 23 Nm

3 - Charge air cooling pump - V188-

□ Removing and fitting  
⇒ [page 194](#)

4 - Coolant hose

5 - Coolant hose

6 - Bracket/bearing/support

□ For charge air cooling pump - V188-

7 - Bolt.

□ 40 Nm

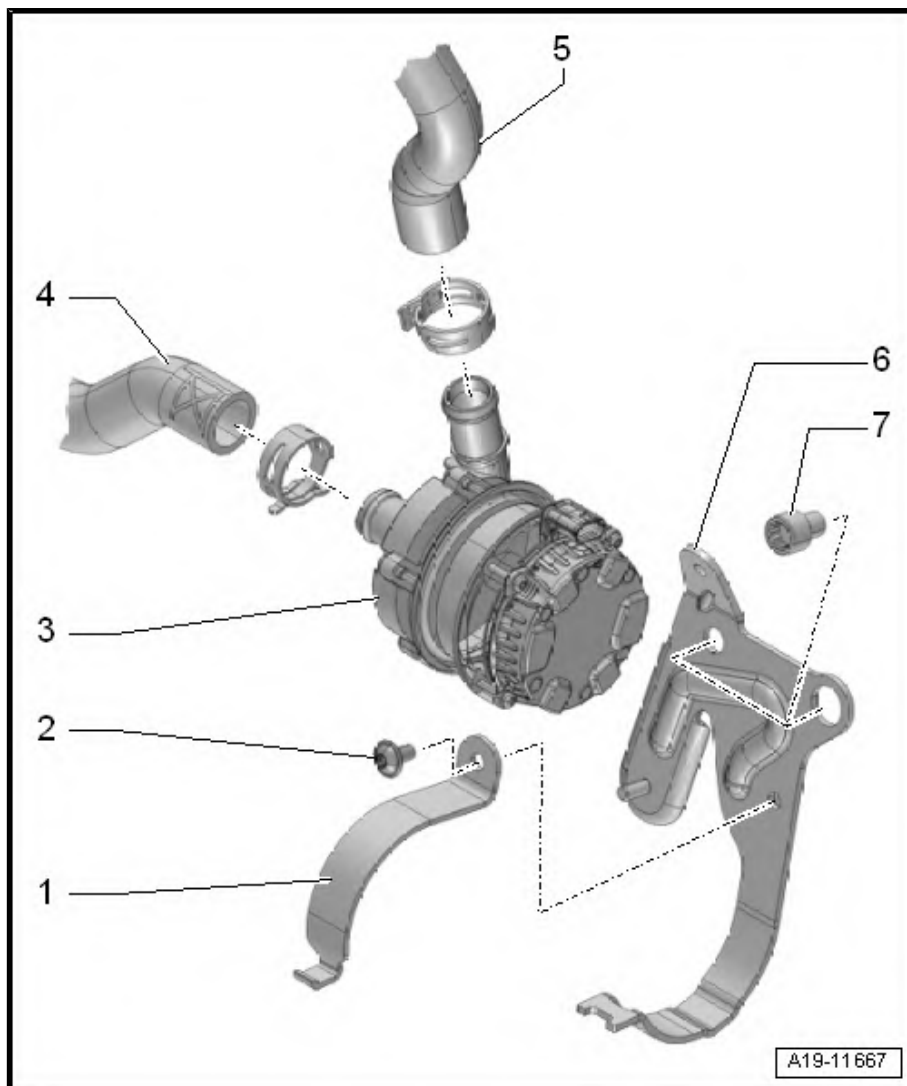

### 2.2.3 Assembly overview - auxiliary pump for heating - V488- , version 2

**1 - Bolt.**

- 1.5 Nm

**2 - Collar**

**3 - Bonded rubber bush**

- Ensure proper seating in bracket

**4 - Bracket/bearing/support**

- For auxiliary pump for heating - V488-

**5 - Bolt.**

- 40 Nm

**6 - Auxiliary pump for heating - V488-**

- Removing and fitting  
⇒ [page 196](#)

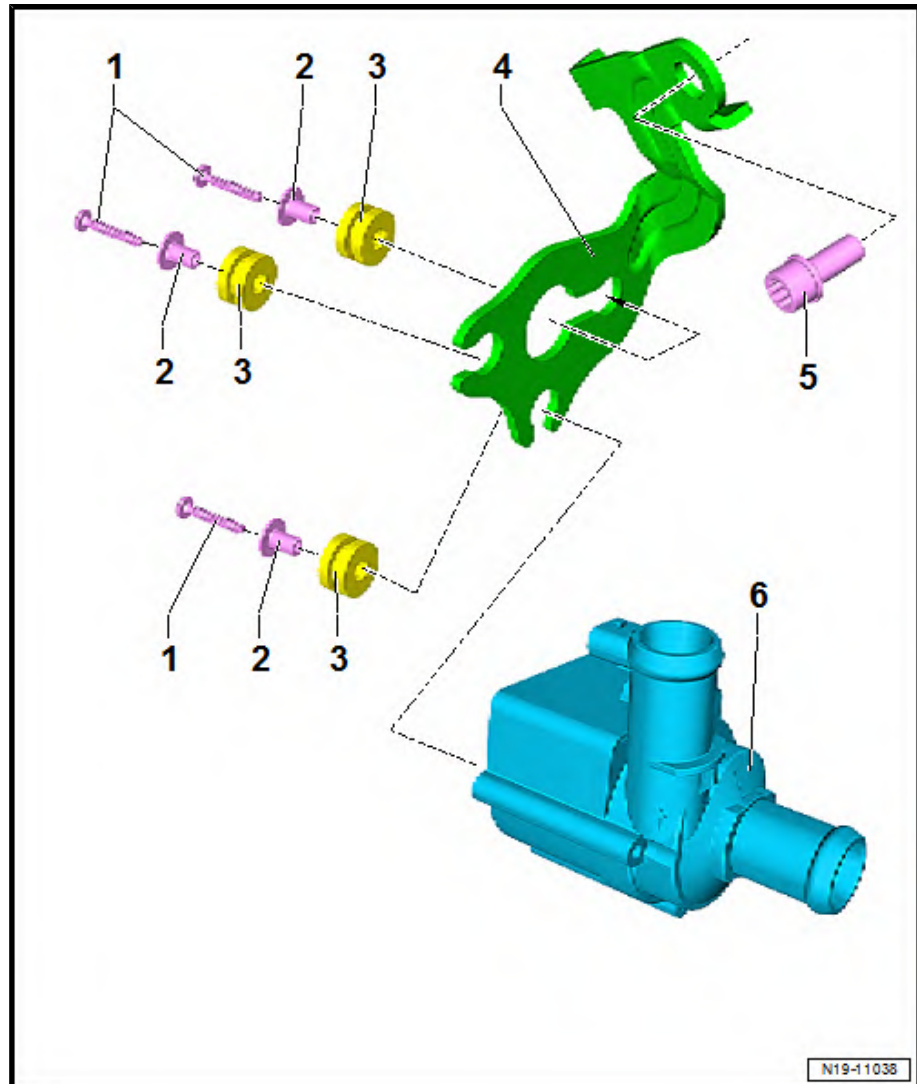

N19-11038

## 2.2.4 Assembly overview - charge air cooling pump - V188- , version 3

- 1 - Bolt.
  - 40 Nm
- 2 - Bracket/bearing/support
  - For charge air cooling pump - V188-
- 3 - Bolt.
  - 23 Nm
- 4 - Retaining clip
- 5 - Charge air cooling pump - V188-
  - Removing and fitting  
⇒ [page 194](#)
- 6 - Rubber mount
- 7 - Clip
- 8 - Coolant hose
- 9 - Clip
- 10 - Coolant hose

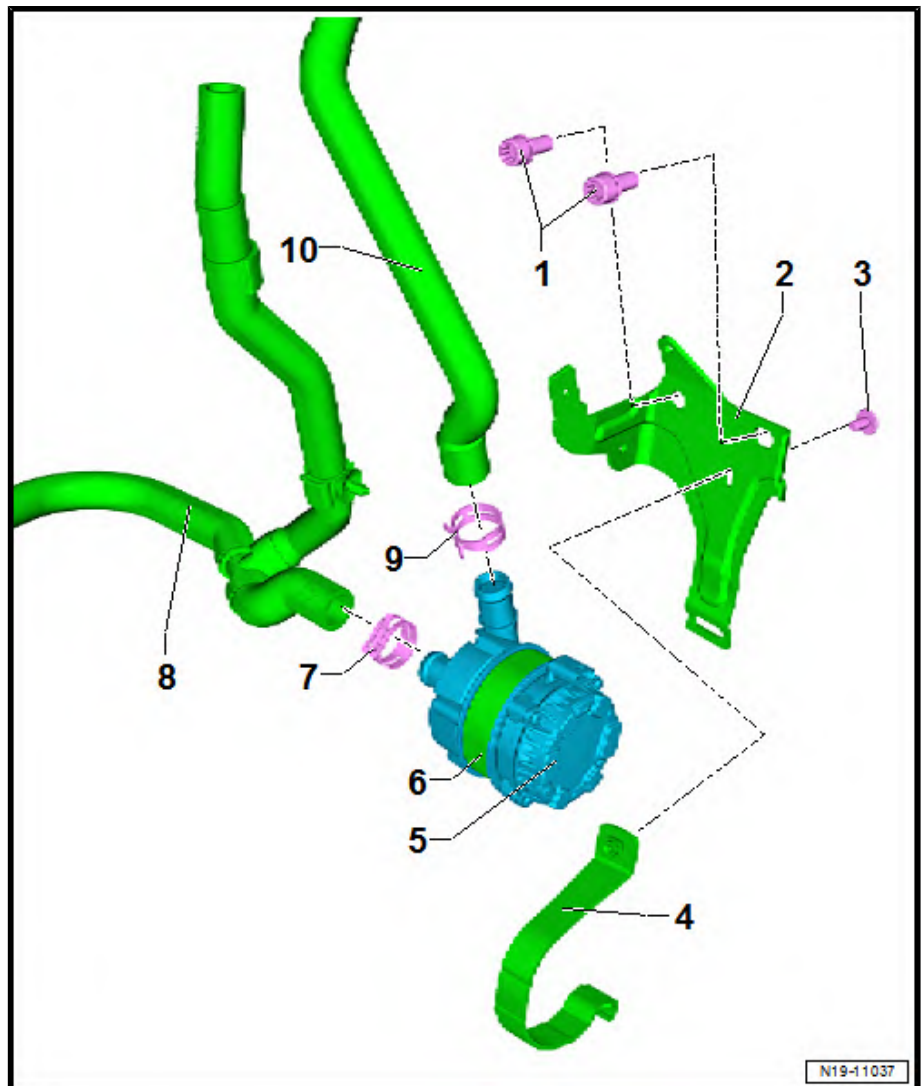

## 2.3 Exploded view - coolant temperature sensors

### 1 - Coolant temperature sensor - G62-

- Removing and fitting  
⇒ [page 206](#)

### 2 - Spacer ring

- Renew if damaged.

### 3 - O-ring

- Renew following removal
- Lubricate with coolant

### 4 - Two-threaded bolt

- 8 Nm

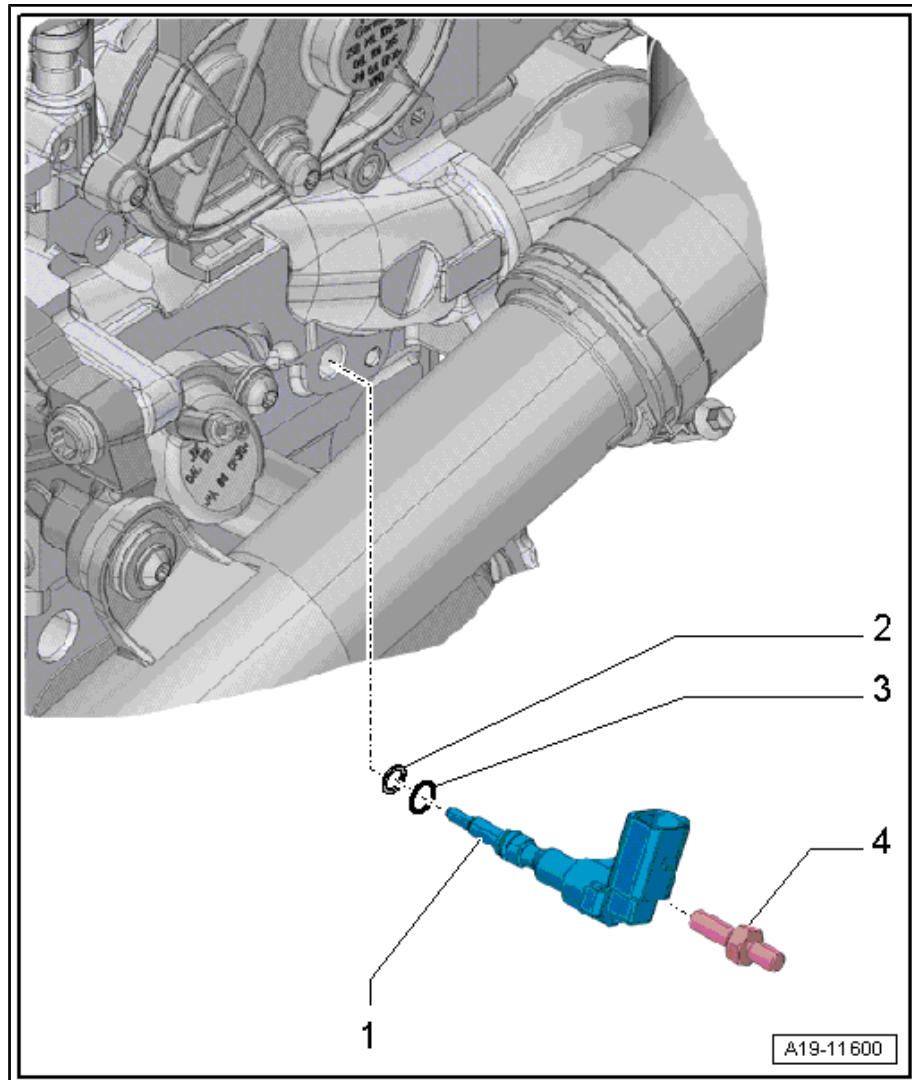

## 2.4 Removing and installing electric coolant pump

⇒ [“2.4.1 Pump for charge air cooling V188 , versions 1 and 2: Removal and installation”, page 194](#)

⇒ [“2.4.2 Auxiliary pump for heating V488 version 1: Removal and installation”, page 196](#)

⇒ [“2.4.3 Pump for charge air cooling V188 , versions 3: Removal and installation”, page 197](#)

⇒ [“2.4.4 Auxiliary pump for heating V488 version 2: Removal and installation”, page 200](#)

### 2.4.1 Pump for charge air cooling - V188- , versions 1 and 2: Removal and installation

Special tools and workshop equipment required

- ◆ Hose clamps, up to 25 mm - 3094-

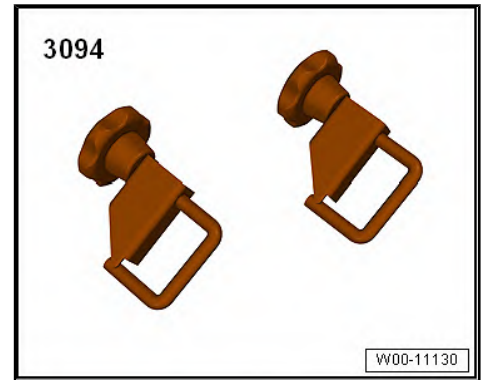

- ◆ Hose clip pliers - VAS 6362-

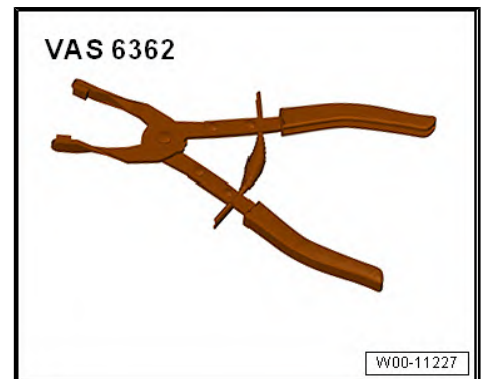

### Removal

- Remove noise insulation ⇒ General body repairs, exterior; Rep. gr. 66 ; Noise insulation; Removing and installing noise insulation .

### Vehicles with charge air cooling pump - V188- version 1

- Unplug the electrical connector -3-.



### Note

*Place a cloth underneath to catch escaping coolant.*

- Clamp off coolant hoses with hose clamps -3094- .
- Loosen the hose clips -2-, remove the coolant hoses.
- Detach the charge air cooling pump - V188- -item 1- from mounting -4-.

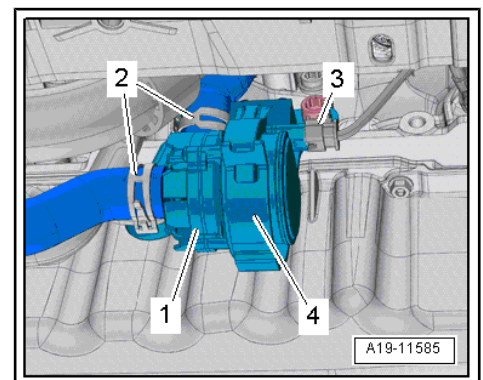

### Vehicles with charge air cooling pump - V188- version 2

- Unplug the electrical connector -3-.



#### Note

*Place a cloth underneath to catch escaping coolant.*

- Pinch off the coolant hoses with hose clamps -3094- .
- Loosen the hose clips -1-, remove the coolant hoses.
- Remove bolt -2-, release retaining tab and remove charge air cooling pump - V188- .

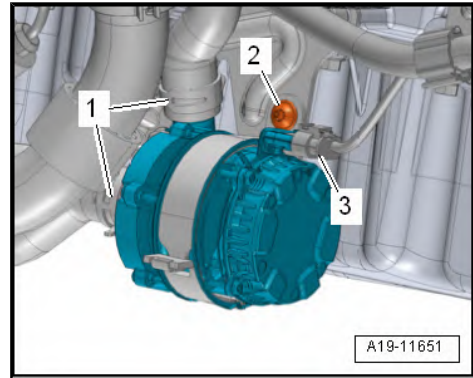

### Installation

Installation is carried out in the reverse order; note the following:



#### Note

*Secure all hose connections with the correct type of hose clips (same as original equipment) ⇒ Electronic parts catalogue .*

- Check coolant level ⇒ [page 187](#) .

### Specified torques

- ◆ ⇒ [“2.2 Exploded view - electric coolant pump”, page 190](#)
- ◆ Assembly overview - Noise insulation ⇒ General body repairs, exterior; Rep. gr. 66 ; Noise insulation; Assembly overview - Noise insulation .

## 2.4.2 Auxiliary pump for heating - V488- version 1: Removal and installation

### Special tools and workshop equipment required

- ◆ Hose clamps, up to 25 mm - 3094-

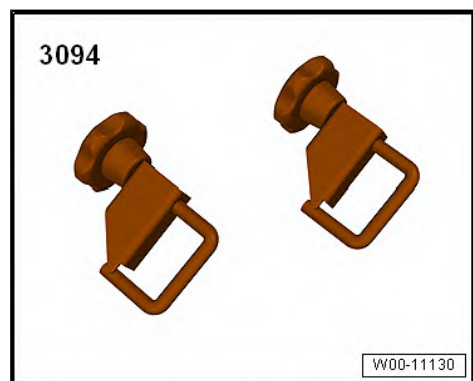

- ◆ Hose clip pliers - VAS 6362-



### Removal

- Remove noise insulation ⇒ General body repairs, exterior; Rep. gr. 66 ; Noise insulation; Removing and installing noise insulation .
- Unplug the electrical connector -3-.

### Note

*Place a cloth underneath to catch escaping coolant.*

- Pinch off the coolant hoses with hose clamps -3094- .
- Loosen the hose clips -4-, remove the coolant hoses.
- Detach auxiliary pump for heating - V488- -item 2- from mounting -1-.

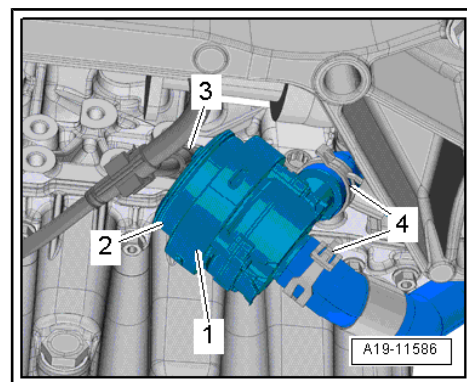

### Installation

Installation is carried out in the reverse order; note the following:

### Note

*Secure all hose connections with the correct type of hose clips (same as original equipment) ⇒ Electronic parts catalogue .*

- Check coolant level ⇒ [page 187](#) .

### Specified torques

- ◆ ⇒ ["2.2 Exploded view - electric coolant pump", page 190](#)
- ◆ Assembly overview - Noise insulation ⇒ General body repairs, exterior; Rep. gr. 66 ; Noise insulation; Assembly overview - Noise insulation .

## 2.4.3 Pump for charge air cooling - V188- , versions 3: Removal and installation

Special tools and workshop equipment required

- ◆ Hose clamps, up to 25 mm - 3094-

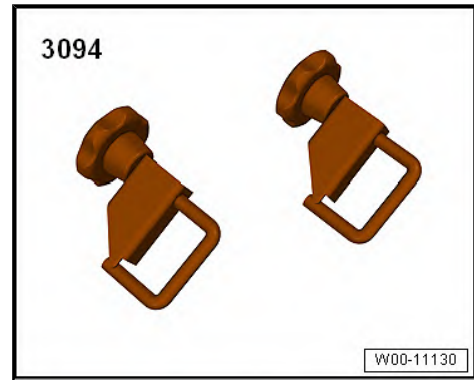

- ◆ Hose clip pliers - VAS 6362-



- ◆ Drip tray for workshop hoist - VAS 6208-



- ◆ Pressing-off lever - 80 - 200-

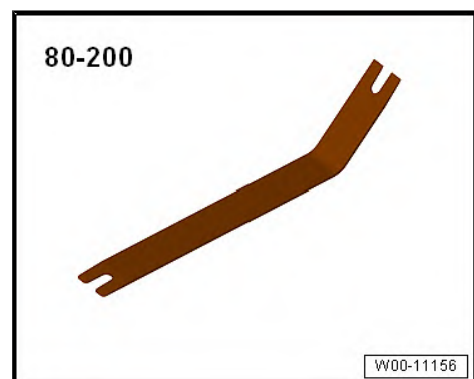

## Removal

- Remove noise insulation ⇒ General body repairs, exterior; Rep. gr. 66 ; Noise insulation; Removing and installing noise insulation .

**If the charge air cooling pump - V188- is to be removed from engine to free some space:**

- Release and unplug electrical connector -3-.
- Use cloth to catch escaping coolant.
- Unclip wiring harness from retainer.
- Open retainer for coolant hose leading to radiator. Detach coolant hose.
- Unclip retainer -6- for coolant hose leading to water radiator for charge air cooling circuit.
- Unscrew the two bolts -2-, and remove charge air cooling pump - V188- together with bracket.
- Lay charge air cooling pump - V188- to one side.

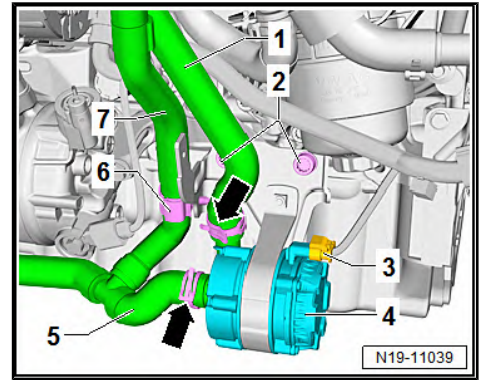

### If the charge air cooling pump - V188- is to be removed:

- Place drip tray for workshop hoist - VAS 6208- underneath.
- Release and unplug electrical connector -3-.



#### Note

Use cloth to catch escaping coolant.

- Use hose clamps -3094- to clamp off coolant hoses -1- and -5-.
- Loosen the hose clips -arrows-, remove the coolant hoses.
- Unclip wiring harness from retainer.
- Open retainer for coolant hose leading to radiator. Detach coolant hose.
- Unclip retainer -6- for coolant hose leading to water radiator for charge air cooling circuit.
- Unscrew the two bolts -2-, and remove charge air cooling pump - V188- together with bracket.

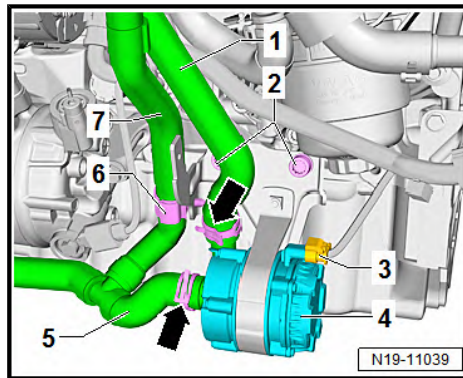

### If charge air cooling pump - V188- is to be removed from bracket:

- Unscrew bolt ⇒ [Item 3 \(page 193\)](#) , and open retaining arm ⇒ [Item 4 \(page 193\)](#) .
- Remove charge air cooling pump - V188- .

#### Installation

Installation is carried out in the reverse order; note the following:

If charge air cooling pump - V188- has been removed from bracket:

- Attach retaining arm ⇒ [Item 4 \(page 193\)](#) at bottom to bracket ⇒ [Item 2 \(page 193\)](#) .
- Remove charge air cooling pump - V188- .
- Make sure that the projection on the rubber bracket ⇒ [Item 6 \(page 193\)](#) is seated in the respective groove in the retaining arm ⇒ [Item 4 \(page 193\)](#) .



#### Note

Secure all hose connections with the hose clips corresponding to original equipment ⇒ *Electronic parts catalogue* .

- Check coolant level ⇒ [page 187](#) .

#### Specified torques

- ◆ ⇒ [“2.2 Exploded view - electric coolant pump”, page 190](#)
- ◆ ⇒ General body repairs, exterior; Rep. gr. 66 ; Noise insulation; Assembly overview - noise insulation

## 2.4.4 Auxiliary pump for heating - V488- version 2: Removal and installation

### Special tools and workshop equipment required

- ◆ Hose clamps, up to 25 mm - 3094-



- ◆ Hose clip pliers - VAS 6362-



- ◆ Drip tray for workshop hoist - VAS 6208-



### Removal

- Remove noise insulation ⇒ General body repairs, exterior; Rep. gr. 66 ; Noise insulation; Removing and installing noise insulation .

### If the auxiliary pump for heating - V488- is to be removed:

- Release and pull off connector -arrow- on oil level and oil temperature sensor - G266- .

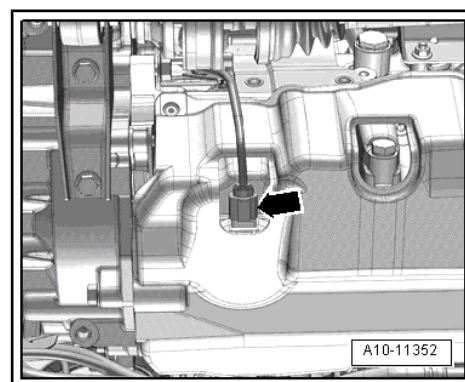

- Move clear electrical wiring harness.
- Place drip tray for workshop hoist - VAS 6208- underneath.
- Release and unplug electrical connector -6-.



**Note**

*Use cloth to catch escaping coolant.*

- Use hose clamps -3094- to clamp off coolant hoses -3- and -4-.
- Loosen the hose clips -arrows- at the bottom of the auxiliary pump for heating - V488- , remove the coolant hoses.
- Unscrew the bolt -2-.
- Remove auxiliary pump for heating - V488- -5- together with bracket -1-.

**If auxiliary pump for heating - V488- is to be removed from engine to free some space:**

- Release and pull off connector -arrow- on oil level and oil temperature sensor - G266- .

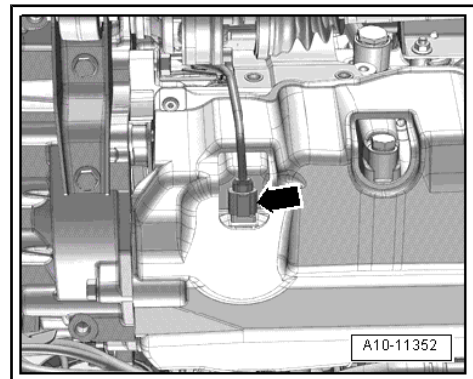
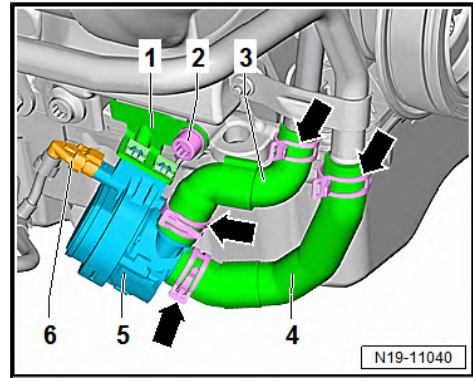

- Move clear electrical wiring harness.
- Release and unplug electrical connector -6-.
- Unscrew the bolt -2-.
- Lay auxiliary pump for heating - V488- -5- to one side.

**If the auxiliary pump for heating - V488- is to be removed from bracket:**

- Unscrew bolts, and remove pump.

#### Installation

Installation is carried out in the reverse order; note the following:

#### Note

*Secure all hose connections with the hose clips corresponding to original equipment => Electronic parts catalogue .*

**If the auxiliary pump for heating - V488- has been removed from bracket:**

- Make sure that rubber the mounting proper is properly seated in bracket.
- Make sure that the spacer sleeves are properly seated in rubber mounting.
- Tighten the nuts.
- Check coolant level => [page 187](#) .

#### Specified torques

- ◆ => ["2.2 Exploded view - electric coolant pump", page 190](#)
- ◆ => General body repairs, exterior; Rep. gr. 66 ; Noise insulation; Assembly overview - noise insulation .

## 2.5 Removing and replacing coolant pump

#### Note

*Checking function by pulling the regulator valve of the coolant pump with your hand is not permitted. This can cause damage to the coolant pump and lead to insufficient supply of coolant to the engine.*

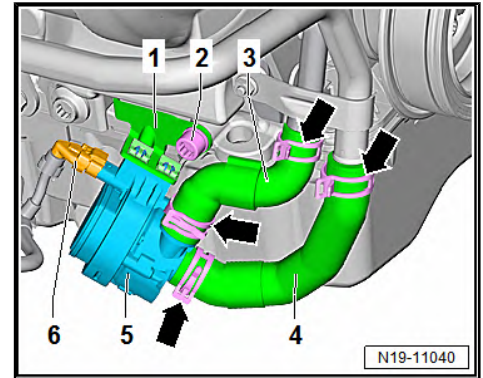

## Removal

- Drain coolant ⇒ [page 181](#) .
- Detach toothed belt from camshaft ⇒ [page 120](#) .
- Remove toothed belt cover (bottom section) ⇒ [page 119](#) .
- Remove bolt -3- and detach coolant valve for cylinder head - N489- -item 2-.
- Remove bolts -arrows- and detach coolant pump -1-.

## Installation

Installation is carried out in the reverse order; note the following:



### Note

*Replace the O-rings.*

- Clean and smoothen sealing surfaces for O-rings.
- Lubricate O-rings with coolant.
- Install notched belt (adjusting valve timing) ⇒ [page 125](#) .
- Replenish coolant ⇒ [page 184](#) .

## Specified torques

- ♦ ⇒ [“2.1 Exploded view - coolant pump and thermostat”, page 188](#)

## 2.6 Cooling system thermostat: removing and installing

### Removal

- Drain coolant ⇒ [page 181](#) .
- For reasons of space, remove the air filter housing together with the intake hose ⇒ [page 321](#) .
- Free coolant hose -3-.
- Remove screws -1-.
- Release locking lugs-arrow-, unclip air hose -2- from the front end and remove in -direction of the arrow-.

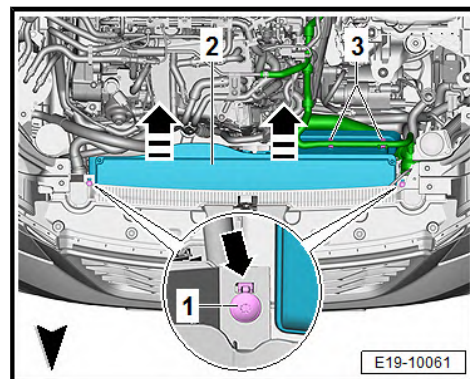
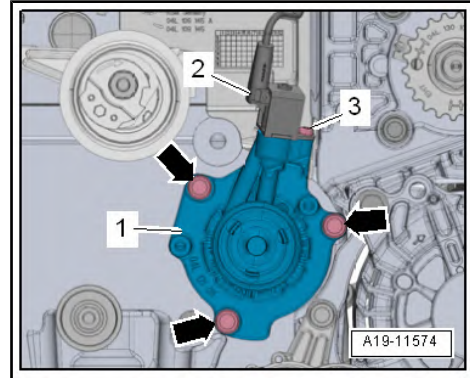

- Remove bolts -arrows-.
- Release screw-type clip -2- and detach air pipe -1-.

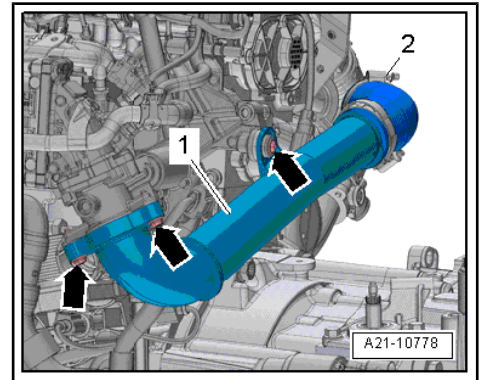

- Release catch -arrow B-.
- Turn connection -1- in direction of -arrow A- and disconnect.
- Detach thermostat.

### Installation

Installation is carried out in the reverse order; note the following:

#### Note

*Renew O-ring.*

- Clean and smooth sealing surface for O-ring.
- Lubricate O-ring with coolant.
- Fit thermostat -2- into thermostat housing.
- Retaining lugs must engage in guides -arrows-.
- Replenish coolant ⇒ [page 184](#) .

### Specified torques

- ◆ ⇒ [“2.1 Exploded view - coolant pump and thermostat”, page 188](#)
- ◆ ⇒ [“2.1 Assembly overview - charge air system”, page 276](#)
- ◆ ⇒ [“4.1 Exploded view - air cleaner housing”, page 319](#)

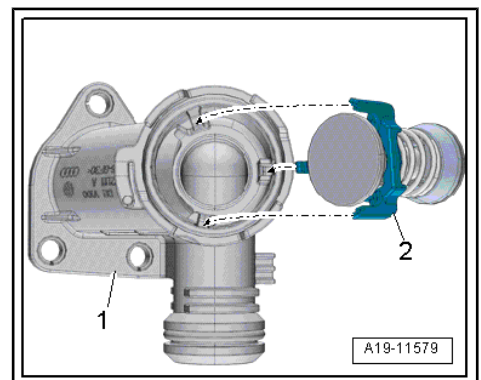
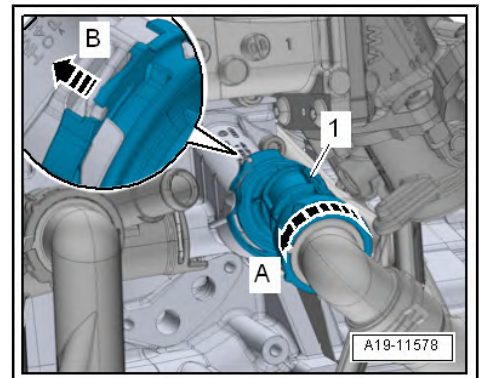

## 2.7 Testing coolant thermostat

- Heat removed thermostat in water bath.

Starts to open	Fully open	Opening travel
87 ± 2 °C	approx. 102 °C <sup>1)</sup>	At least 9 mm
• <sup>1)</sup> Cannot be tested.		

## 2.8 Removing and installing coolant valve for cylinder head - N489-

### Removal

- Remove toothed belt cover (top) ⇒ [page 116](#) .
- Unplug electrical connector -2- and move wiring clear.
- Remove bolt -3- and detach coolant valve for cylinder head - N489- -item 1-.

### Installation

Installation is carried out in the reverse order; note the following:



### Note

*Replace the O-rings.*

- Install toothed belt cover (top) ⇒ [page 116](#) .

### Specified torques

- ◆ ⇒ [“2.1 Exploded view - coolant pump and thermostat”, page 188](#)

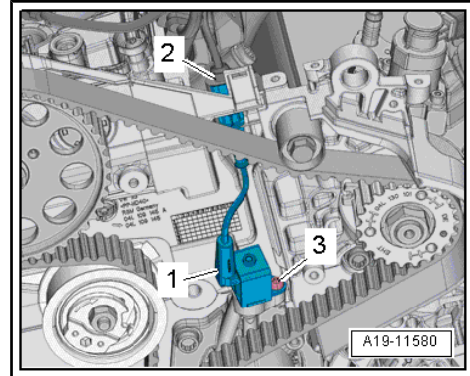

## 2.9 Removing and installing coolant temperature sender - G62-

### Removal

- Engine cold.
- Open filler cap -arrow- of the coolant expansion tank briefly to relieve residual pressure in cooling system.
- For reasons of space, remove the air filter housing together with the intake hose ⇒ [page 321](#) .

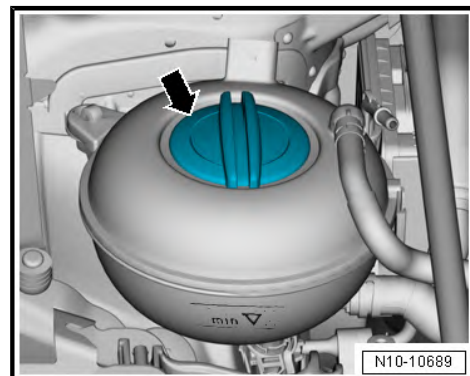

- Remove bolts -arrows-.
- Release screw-type clip -2- and detach air pipe -1-.

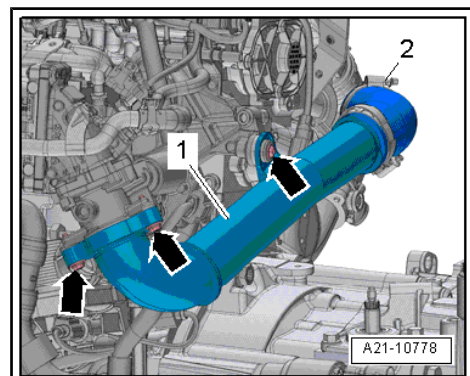

- Remove the gear and gate selector cables from the gearbox, unscrew the counterhold tool and set it down to one side with the gear selector cables ⇒ Rep. gr. 34 ; Selector mechanism; Assembly overview – Selector mechanism .
- Lay the wiring harness -1- free and set aside.
- Remove nut -4- and bolts -2 and 3-.
- Push coolant pipes slightly to the left.

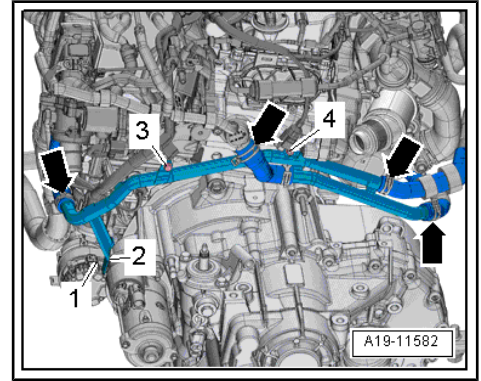

- Unplug the electrical connector -1-.
- Unscrew centre hex stud -2- and pull off coolant temperature sender - G62- .

 **Note**

*If an O-ring or spacer ring remains lodged in cylinder head, lift it out with a piece of wire.*

**Installation**

Installation is carried out in the reverse order; note the following:

 **Note**

- ◆ *Renew O-rings after removal.*
- ◆ *Renew spacer ring if damaged.*
- Install coolant pipes (left-side) ⇒ [page 215](#) .
- Check coolant level ⇒ [page 187](#) .

**Specified torques**

- ◆ ⇒ [“1.1 Exploded view - cylinder head”, page 90](#)
- ◆ ⇒ [“4.1 Exploded view - air cleaner housing”, page 319](#)
- ◆ ⇒ [“5.1 Exploded view - intake manifold”, page 323](#)

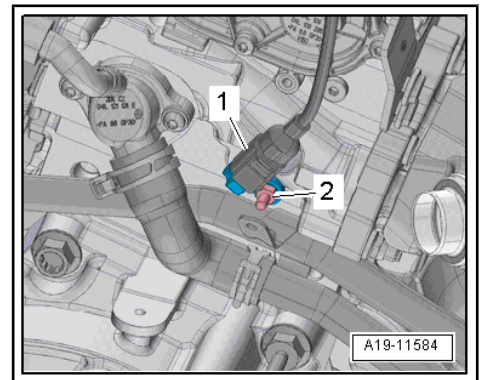

### 3 Coolant pipes

⇒ "3.1 Exploded view - coolant pipes", page 208

⇒ "3.2 Removing and installing coolant pipes", page 209

#### 3.1 Exploded view - coolant pipes



#### Note

The arrow markings on coolant pipes and on ends of hoses must align.

#### 1 - Nut

- 10 Nm

#### 2 - Coolant pipe (front right)

- Removing and fitting  
⇒ [page 214](#)

#### 3 - Bolt.

- 10 Nm

#### 4 - Bolt.

- 10 Nm

#### 5 - Coolant pipes (top front)

- Removing and fitting  
⇒ [page 209](#)

#### 6 - Coolant pipe (rear right)

- Removing and fitting  
⇒ [page 219](#)

#### 7 - O-ring

- Renew following removal
- Lubricate with coolant

#### 8 - Bolt.

- 10 Nm

#### 9 - Bolt.

- 23 Nm

#### 10 - Nut

- 10 Nm

#### 11 - Rear coolant pipe

- Removing and fitting  
⇒ [page 217](#)

#### 12 - Bolt.

- 10 Nm

#### 13 - Bolt.

- 10 Nm

#### 14 - Bolt.

- 10 Nm

#### 15 - Coolant pipe (front left)

- Removing and fitting ⇒ [page 212](#)

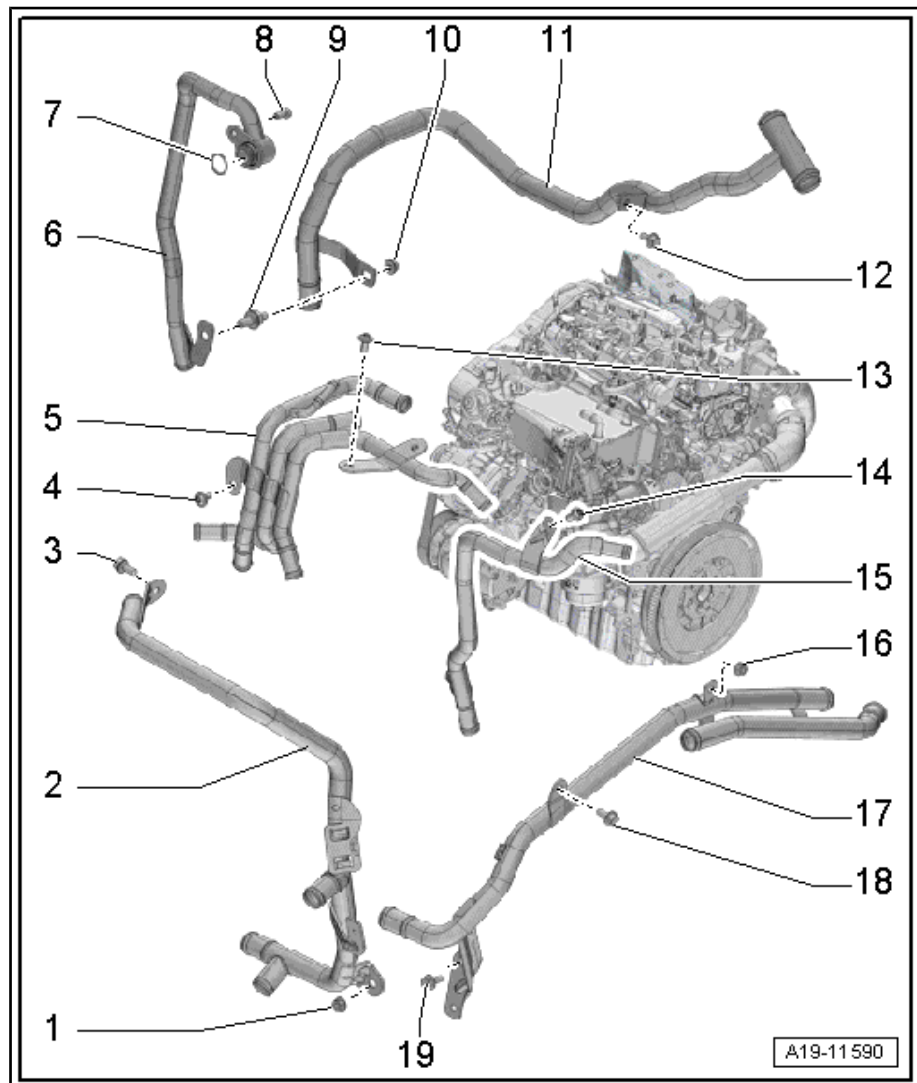

**16 - Nut**

- 10 Nm

**17 - Coolant pipes (left-side)**

- Removing and fitting ⇒ [page 215](#)

**18 - Bolt.**

- 8 Nm

**19 - Bolt.**

- 8 Nm

## 3.2 Removing and installing coolant pipes

⇒ [“3.2.1 Coolant pipes \(top front\): removing and installing”, page 209](#)

⇒ [“3.2.2 Removing and installing coolant pipe \(bottom front\)”, page 210](#)

⇒ [“3.2.3 Coolant pipe \(front left\): removing and installing”, page 212](#)

⇒ [“3.2.4 Removing and installing coolant pipe \(front right\)”, page 214](#)

⇒ [“3.2.5 Removing and installing coolant pipes \(left-side\)”, page 215](#)

⇒ [“3.2.6 Removing and installing coolant pipe \(rear\)”, page 217](#)

⇒ [“3.2.7 Removing and installing coolant pipe \(rear right\)”, page 219](#)

### 3.2.1 Coolant pipes (top front): removing and installing

#### Special tools and workshop equipment required

- ◆ Hose clip pliers - VAS 6362-

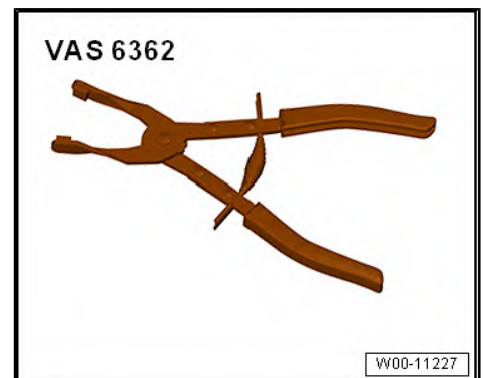

#### Removal

- Remove engine cover. ⇒ [page 56](#)
- Remove the air filter housing ⇒ [page 321](#)

- Free coolant hose -3-.
- Remove screws -1-.
- Release locking lugs-arrow-, unclip air hose -2- from the front end and remove in -direction of the arrow-.
- Drain coolant ⇒ [page 181](#) .

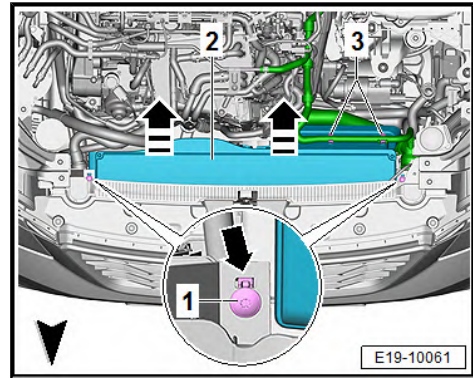

- Unclip bracket -1- with fuel hoses.
- Remove bolts -arrows-.
- Loosen the hose clip -3-, remove the coolant hose.

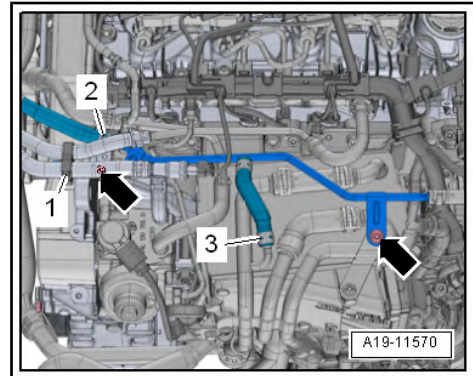

- Remove bolts -2-.



**Note**

*Depending on the version, the number of connected coolant hoses may be different.*

- Loosen the hose clips -arrows-, remove the coolant hoses.
- Remove coolant pipes -1- at top front.

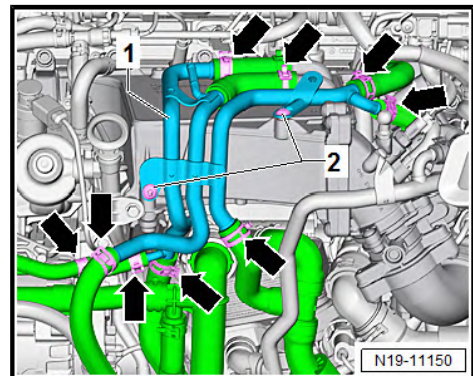

**Installation**

Installation is carried out in the reverse order; note the following:



**Note**

*Secure all hose connections with the correct type of hose clips (same as original equipment) ⇒ *Electronic parts catalogue* .*

- Replenish coolant ⇒ [page 184](#) .
- Install engine cover panel ⇒ [page 56](#) .

**Specified torques**

- ◆ ⇒ [“3.1 Exploded view - coolant pipes”, page 208](#)
- ◆ ⇒ [“4.1 Exploded view - air cleaner housing”, page 319](#)

### 3.2.2 Removing and installing coolant pipe (bottom front)

Special tools and workshop equipment required

- ◆ Hose clip pliers - VAS 6362-

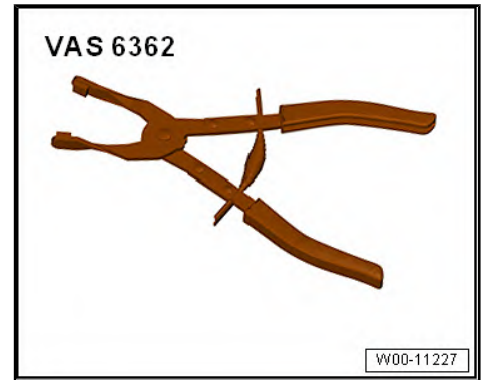

- ◆ Protective mat - VAS 531003-

#### Removal

- Remove engine cover. ⇒ [page 56](#)
- For reasons of space, remove the air filter housing together with the intake hose ⇒ [page 321](#) .
- Remove radiator cowl ⇒ [page 244](#) .
- Install protective mat - VAS 531003- to vehicle as shown in illustration.
- Drain coolant ⇒ [page 181](#) .
- Remove oil filter housing ⇒ [page 172](#) .

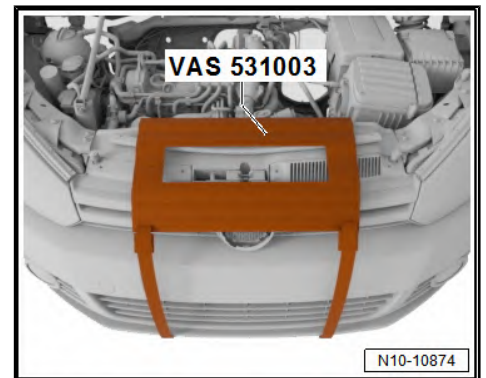

- Remove bolts -arrows-.
- Release screw-type clip -2- and detach air pipe -1-.
- Remove throttle valve control unit - J338- ⇒ [page 328](#)

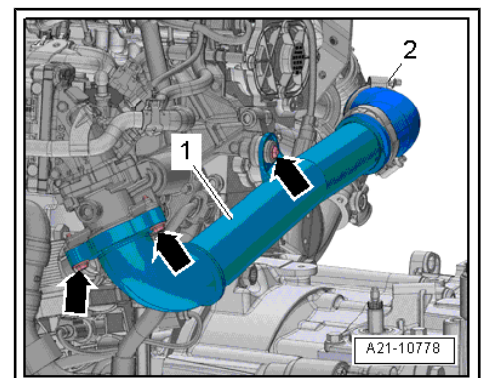

- Remove bolts -arrows- and move bracket -1- with electrical wiring harness to one side.

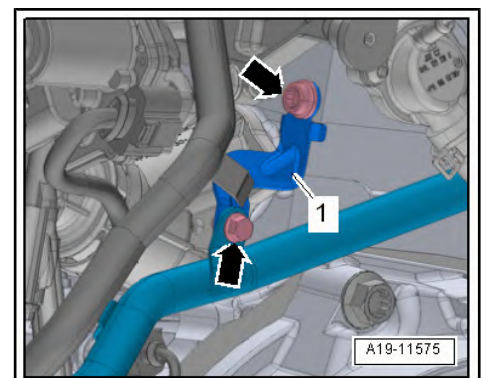

- Lift the retaining clip -4-, remove the coolant hose.
- Remove bolts -arrows-.
- Pull off securing clip -2-, disconnect thermostat housing -3- from coolant pipe (bottom front) -1- and detach.

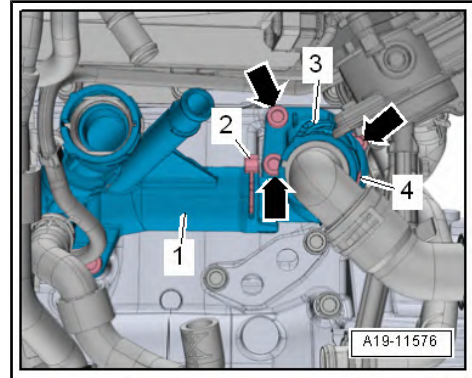

- Loosen the hose clip -1-, remove the coolant hose.
- Unscrew the bolt -4-.
- Detach and remove coolant pipe (bottom front) -3-, taking care not to damage vacuum line -2-.

### Installation

Installation is carried out in the reverse order; note the following:



#### Note

- ◆ *Renew seals and O-rings after each removal.*
- ◆ *Secure all hose connections with the correct type of hose clips (same as original equipment) ⇒ [Electronic parts catalogue](#) .*
- Clean and smoothen sealing surfaces for seals and O-rings.
- Lubricate seals and O-rings with coolant.
- Install oil filter housing ⇒ [page 172](#) .
- Connect coolant hose with plug-in connector ⇒ [page 228](#) .
- Replenish coolant ⇒ [page 184](#) .

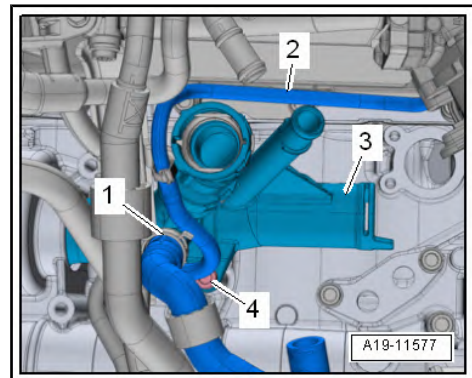

### Specified torques

- ◆ ⇒ [“2.1 Exploded view - coolant pump and thermostat”, page 188](#)
- ◆ ⇒ [“5.1 Exploded view - intake manifold”, page 323](#)
- ◆ ⇒ [“4.2 Exploded view - radiator cowl and radiator fans”, page 229](#)

## 3.2.3 Coolant pipe (front left): removing and installing

Special tools and workshop equipment required

- ◆ Hose clip pliers - VAS 6362-



### Removal

- Remove engine cover. ⇒ [page 56](#)
- Remove radiator cowl ⇒ [page 244](#) .
- Drain coolant ⇒ [page 181](#) .

### Variant 1:

- Lift the retaining clip -1-, remove the coolant connection.
- Unscrew the bolt -2-.
- Unfasten hose clips -arrows-, remove the coolant hoses.
- Detach coolant pipe (front left).

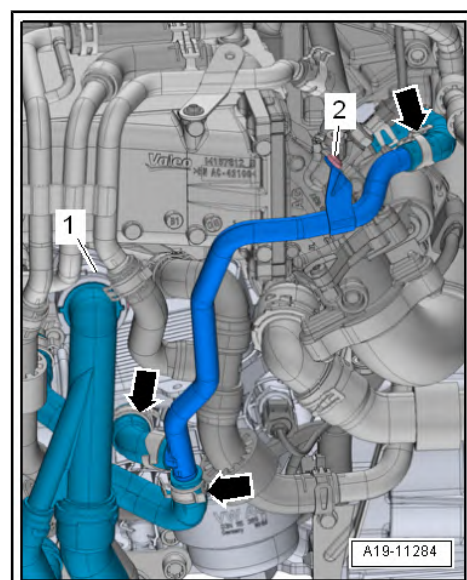



## Removal

- Drain coolant ⇒ [page 181](#) .
- Remove the poly V-belt ⇒ [page 59](#) .
- Remove the A/C compressor with connected refrigerant hoses from the bracket ⇒ Rep. gr. 87 ; A/C compressor; Attaching/ detaching the A/C compressor to/from the bracket and tie it up to the right.
- Loosen the hose clips -1, 4, 6- and remove the coolant hoses.
- Unscrew nut -5- and bolt -2-.
- Move coolant hoses -3- clear and disconnect coolant pipe (front right).

## Installation

Installation is carried out in the reverse order; note the following:



### Note

Secure all hose connections with the correct type of hose clips (same as original equipment) ⇒ *Electronic parts catalogue* .

- Fit poly V-belt ⇒ [page 59](#) .
- Replenish coolant ⇒ [page 184](#) .

### Specified torques:

- ◆ ⇒ [“3.1 Exploded view - coolant pipes”, page 208](#)
- ◆ Assembly overview - drive unit of the air conditioner compressor ⇒ Rep. gr. 87 ; Air conditioner compressor; Assembly overview - drive unit of air conditioner compressor

## 3.2.5 Removing and installing coolant pipes (left-side)

### Special tools and workshop equipment required

- ◆ Hose clip pliers - VAS 6340-

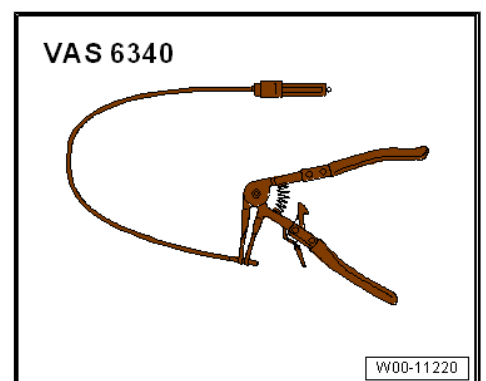
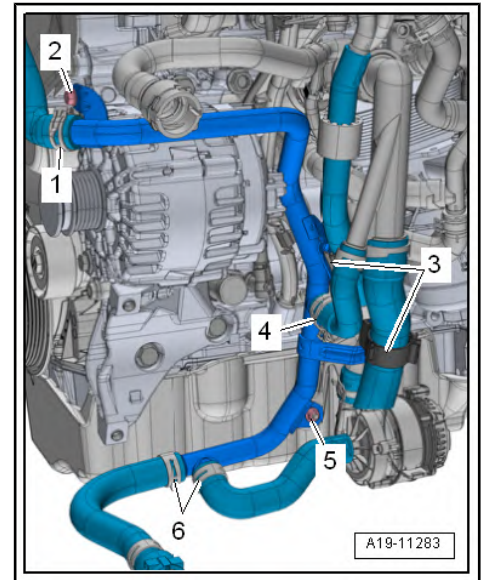

- ◆ Hose clip pliers - VAS 6362-

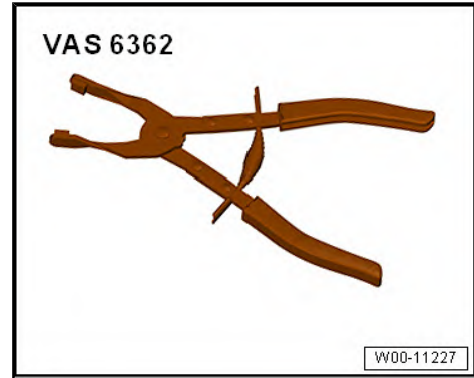

### Removal

- Drain coolant ⇒ [page 181](#) .
- Remove engine cover. ⇒ [page 56](#)
- For reasons of space, remove the air filter housing together with the intake hose ⇒ [page 321](#) .
- Free coolant hose -3-.
- Remove screws -1-.
- Release locking lugs-arrow-, unclip air hose -2- from the front end and remove in -direction of the arrow-.

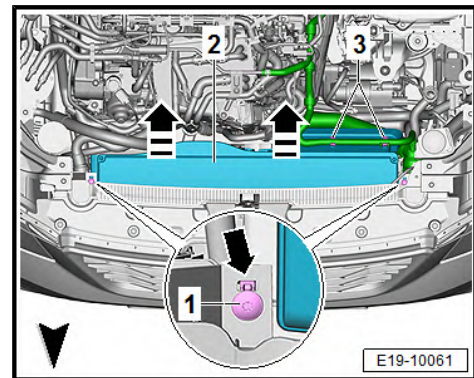

- Remove bolts -arrows-.
- Release screw-type clip -2- and detach air pipe -1-.
- Remove the gear and gate selector cables from the gearbox, unscrew the counterhold tool and set it down to one side with the gear selector cables ⇒ Rep. gr. 34 ; Selector mechanism; Assembly overview – Selector mechanism .

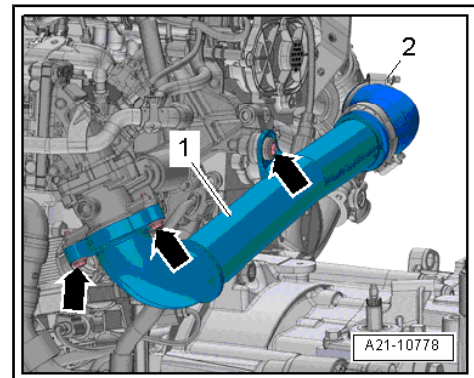

### Vehicles with manual gearbox

- Lay the wiring harness -1- free and set aside.
- Remove nut -4- and bolts -2 and 3-.
- Loosen the hose clips -arrows-, remove the coolant hoses.
- Detach coolant pipes (left-side).

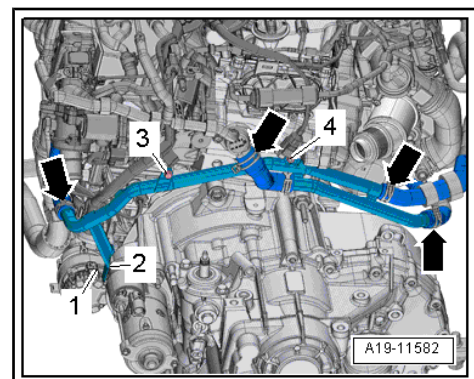

### Vehicles with DSG gearbox:

- Lay the wiring harness -1- free and set aside.
- Remove nut -4- and bolts -2 and 3-.
- Loosen hose clips -arrows- and remove ends of air hoses.
- Detach coolant pipes (left-side).

### Installation

Installation is carried out in the reverse order; note the following:



#### Note

*Secure all hose connections with the correct type of hose clips (same as original equipment) ⇒ Electronic parts catalogue .*

- Replenish coolant ⇒ [page 184](#) .

### Specified torques

- ◆ Screw-type clip, charge air pipe: 5.5 Nm
- ◆ ⇒ [“3.1 Exploded view - coolant pipes”, page 208](#)
- ◆ ⇒ [“4.1 Exploded view - air cleaner housing”, page 319](#)
- ◆ ⇒ [“5.1 Exploded view - intake manifold”, page 323](#)
- ◆ Assembly overview - selector mechanism ⇒ Rep. gr. 34 ;  
 Selector mechanism; Assembly overview - selector mechanism .

## 3.2.6 Removing and installing coolant pipe (rear)

### Special tools and workshop equipment required

- ◆ Drip tray for workshop hoist - VAS 6208-

- ◆ Hose clip pliers - VAS 6340-

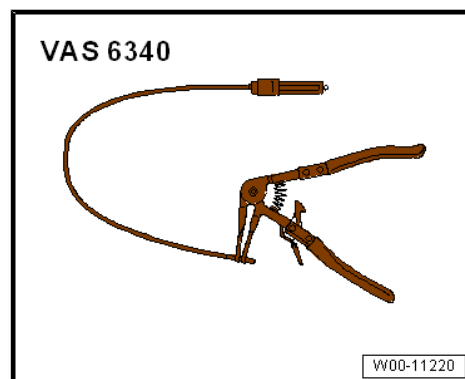
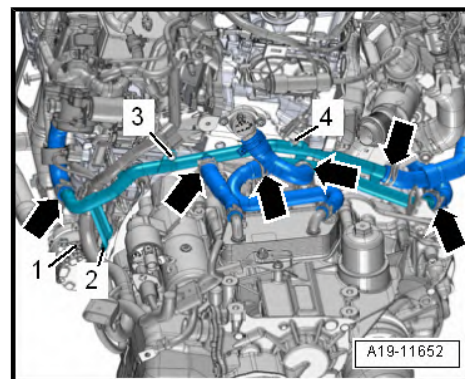

- ◆ Hose clip pliers - VAS 6362-



### Removal

- Remove noise insulation ⇒ General body repairs, exterior; Rep. gr. 66 ; Noise insulation; Removing and installing noise insulation .

### Vehicles with four-wheel drive

- Remove front exhaust pipe ⇒ [page 378](#) .
- Remove bolts -arrows- and detach heat shield -1-.

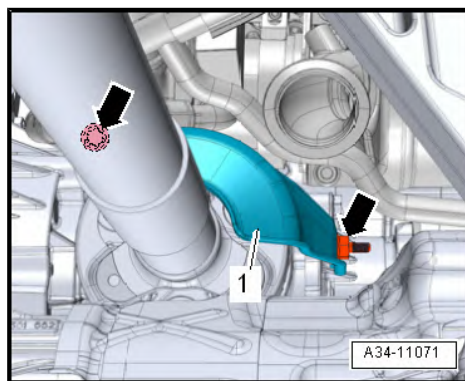

### All vehicles (continued):

- Place drip tray for workshop hoist - VAS 6208- underneath.
- Loosen the hose clip -4-, remove the coolant hose, drain the coolant.
- Loosen the hose clips -1-, remove the coolant hoses.
- Remove nut -3- and bolt -2- and detach coolant pipe (rear).

### Installation

Installation is carried out in the reverse order; note the following:

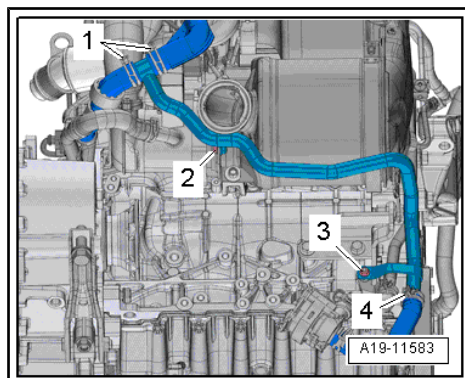

- Tighten bolt -2- and then nut -3-

 **Note**

Secure all hose connections with the correct type of hose clips (same as original equipment) ⇒ *Electronic parts catalogue* .

- Replenish coolant ⇒ [page 184](#) .

**Specified torques**

- ◆ ⇒ [“3.1 Exploded view - coolant pipes”, page 208](#)
- ◆ Assembly overview - Noise insulation ⇒ General body repairs, exterior; Rep. gr. 66 ; Noise insulation; Assembly overview - Noise insulation .

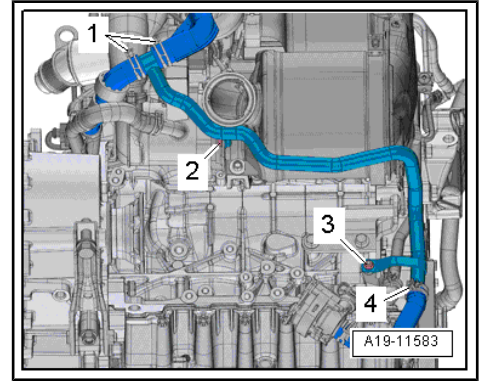

### 3.2.7 Removing and installing coolant pipe (rear right)

**Special tools and workshop equipment required**

- ◆ Hose clip pliers - VAS 6362-

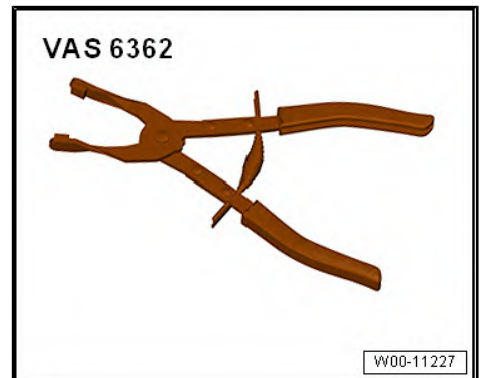

- ◆ Assembly tool - T10511-

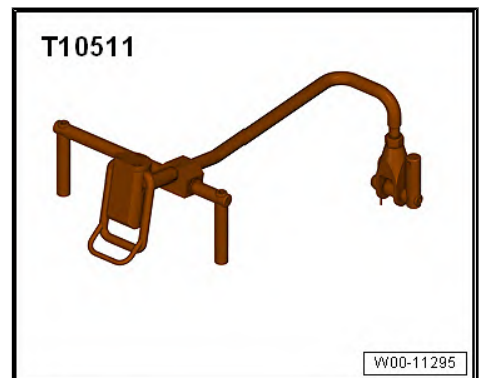

- ◆ Socket insert XZN 10 - T10501-



## Removal



### Note

*Re-attach all heat insulation sleeves at the same locations when re-installing.*

- Remove engine cover. ⇒ [page 56](#)
- Drain coolant ⇒ [page 181](#) .
- Remove the rear coolant pipe ⇒ [page 217](#) .
- Remove coolant pipes (left-side) ⇒ [page 215](#) .
- Remove front exhaust pipe ⇒ [page 378](#) .

### LHD vehicles with pressure differential sender - G505- :

- Open heat insulation sleeve -1-.
- Take electrical connector -4- out of bracket, unplug it and move electrical wiring clear.
- Unplug electrical connectors -3, 5- and move electrical wiring harness clear.
- Remove bolt -2- and move bracket with pressure differential sender - G505- towards rear.

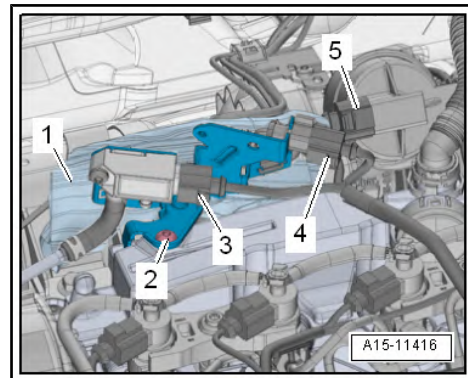

### LHD vehicles with exhaust gas pressure sensor 1 - G450- and pressure differential sender - G505- :

- Open heat insulation sleeve -1-.
- Take electrical connector -5- out of bracket, unplug it and move electrical wiring clear.
- Disconnect electrical connectors -3, 4 and 6- and move wiring harness clear.
- Unscrew the bolt -2-.

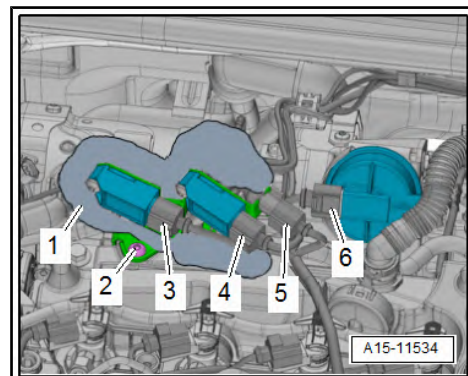

### All vehicles (continued):

- Unscrew the bolt -3-.
- Unclip pipes -2- on toothed belt guard.



### Note

*Item -1- can be disregarded.*

- Move bracket with pressure differential senders back.

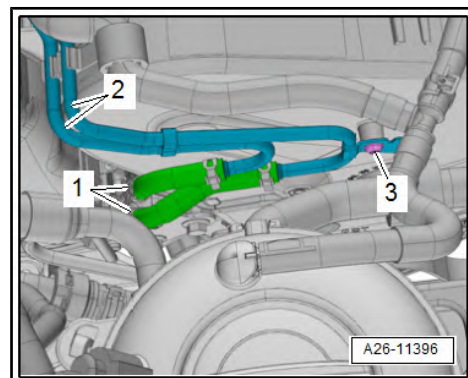

- Bend up and remove the clamp -1- of the emission control module.
- Unscrew the bolt -5-.

**i** Note

*The legs of the assembly aid - T10511- are positioned on the heads of the bolts for the cylinder head cover.*

- Fit assembly tool - T10511- as shown.
- Attach retaining bracket -arrow- in lifting shackle of emission control module.

- Press the release buttons on the crankcase breather hose -1- and remove it from the cylinder head cover.
- Unscrew bolt -3-, swing air pipe with inlet connection -2- to rear and pull off from turbocharger.

- Unscrew bolts -arrows- and remove resonator -1-.

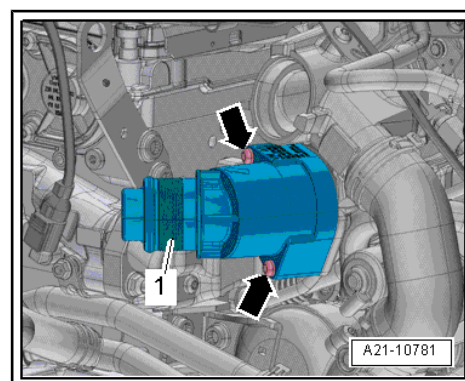
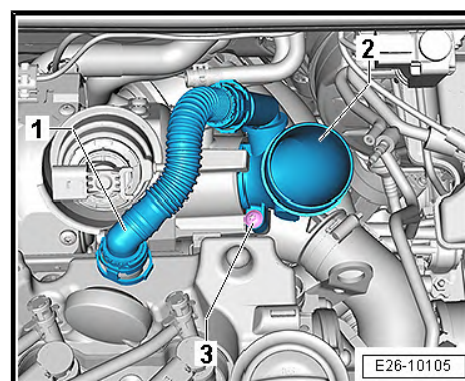
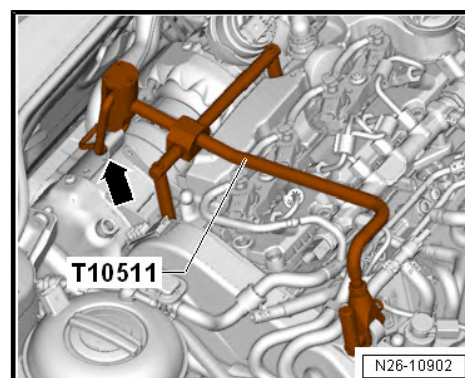
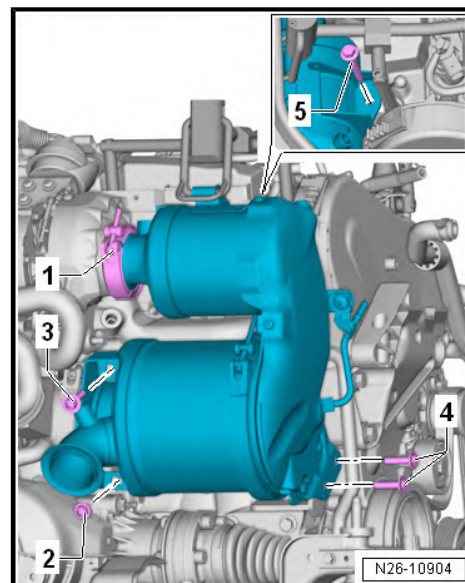

- Loosen the hose clip -1-, remove the coolant hose.
- Loosen bolt -2-, remove bolt -3- and pivot coolant pipe clear to one side.

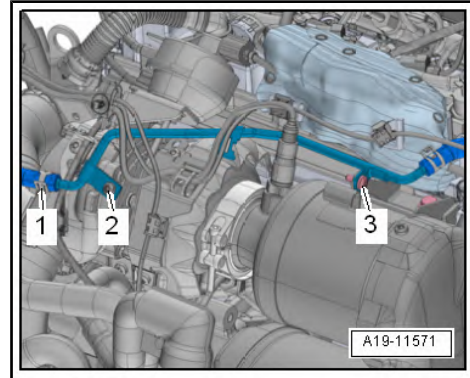

- Unplug electrical connectors and move wiring clear:
- 2 - For exhaust gas temperature sender 4 - G648-
- 3 - For exhaust gas temperature sender 3 - G495-
- 4 - For Lambda probe 1 before catalytic converter - GX10- .

**Vehicles with four-wheel drive**

- Unbolt drive shaft (right-side) from bevel box ⇒ Rep. gr. 40 ; Drive shaft; Exploded view - drive shaft .

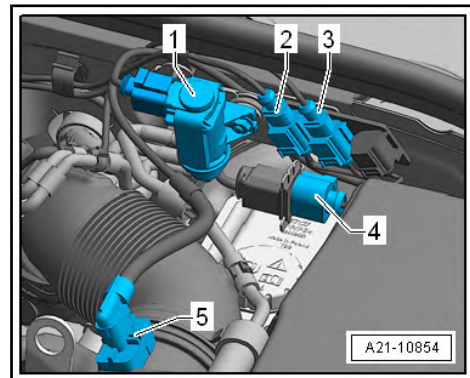

**All vehicles (continued):**

- Push heat insulation sleeve to one side and unplug electrical connector -5-.
- Loosen the hose clip -3-, remove the air intake hose.
- Loosen the hose clip -4-, remove the coolant hose.
- Unscrew bolt -2- with bit XZN 10 - T10501- .

**Note**

Ignore -item 6-.

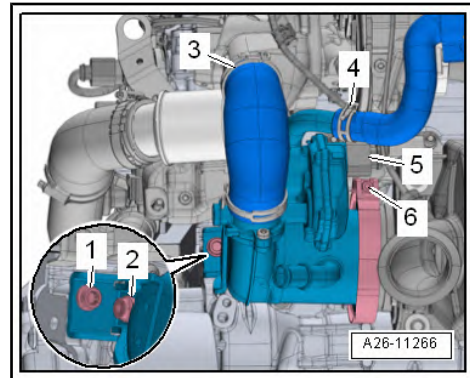

- Remove screws -4-.
- Unscrew the bolts -5 and 6- with the XZN 10 - T10501- .
- Pull down mechanism -2- of assembly tool - T10511- in -direction of arrow - to release the retaining bracket of the transportation shackle of the emission control module.
- Push the emission control module and the cooler for exhaust recirculation towards the back.

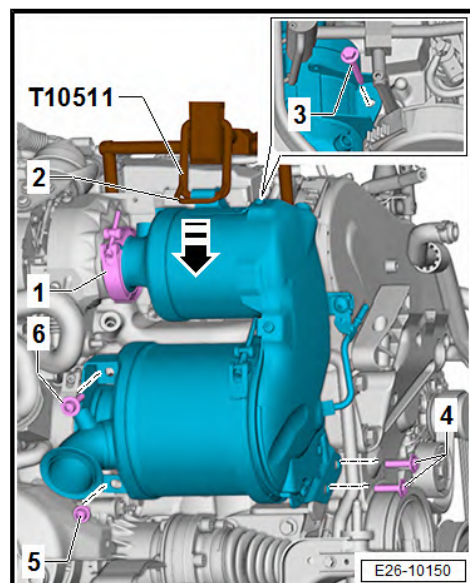

- Loosen the hose clip -1-, remove the coolant hose.
- Remove centre hex stud -2- and bolt -3- and take off coolant pipe (rear right).

### Installation

Installation is carried out in the reverse order; note the following:

#### Note

- ◆ *Renew O-ring.*
- ◆ *Secure all hose connections with the correct type of hose clips (same as original equipment) ⇒ [Electronic parts catalogue](#) .*
- Install emission control module ⇒ [page 390](#) .
- Install the exhaust pipe ⇒ [page 378](#) .
- Install the coolant pipe (rear) ⇒ [page 217](#) .
- Start bolts -2- and -3-, and tighten them to 10 Nm.
- Install coolant pipes (left-side) ⇒ [page 215](#) .
- Install engine cover panel ⇒ [page 56](#) .
- Replenish coolant ⇒ [page 184](#) .

### Specified torques

- ◆ ⇒ [“2.1 Assembly overview - emission control”, page 385](#)
- ◆ ⇒ [“4.2 Assembly overview - Control motor for exhaust gas recirculation V338”, page 425](#)
- ◆ ⇒ [“3.1 Assembly overview - exhaust gas temperature regulation”, page 411](#)
- ◆ ⇒ [“3.1 Exploded view - coolant pipes”, page 208](#)
- ◆ ⇒ [“1.1 Exploded view - silencers”, page 366](#)

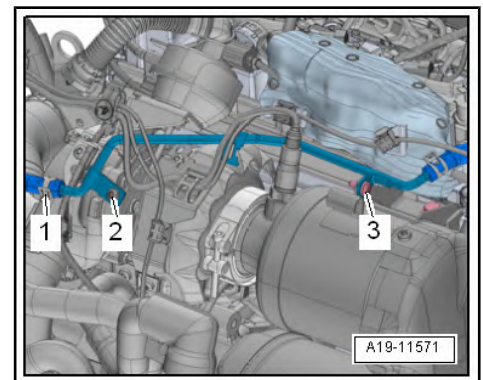
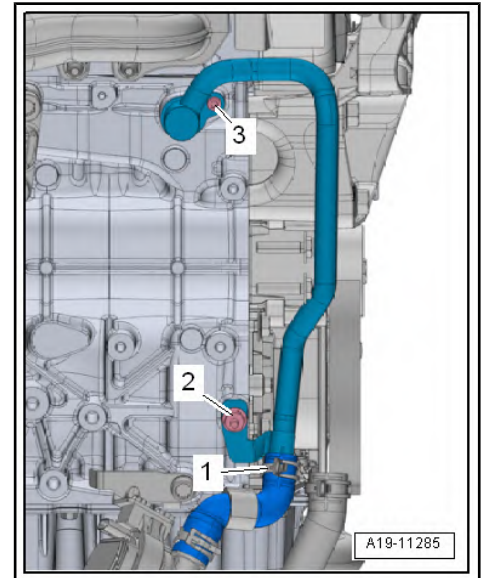

## 4 Radiator/radiator fans

- ⇒ [“4.1 Exploded view - radiator/radiator fans”, page 224](#)
- ⇒ [“4.2 Exploded view - radiator cowl and radiator fans”, page 229](#)
- ⇒ [“4.3 Assembly overview - radiator blind”, page 230](#)
- ⇒ [“4.4 Removing and positioning radiator”, page 233](#)
- ⇒ [“4.5 Removing and installing cooler for charge air cooling circuit”, page 239](#)
- ⇒ [“4.6 Removing and installing radiator cowling with radiator fan”, page 244](#)
- ⇒ [“4.7 Removing and installing radiator fans”, page 244](#)
- ⇒ [“4.8 Removing and installing radiator blind”, page 245](#)
- ⇒ [“4.9 Removing and installing radiator blind control motor V544”, page 247](#)

### 4.1 Exploded view - radiator/radiator fans

- ⇒ [“4.1.1 Assembly summary - radiator/radiator fan, version 1”, page 224](#)
- ⇒ [“4.1.2 Assembly summary - radiator/radiator fan, version 2”, page 226](#)
- ⇒ [“4.1.3 Assembly summary - radiator/radiator fan, version 3”, page 227](#)
- ⇒ [“4.1.4 Plug-in connectors of coolant hoses”, page 228](#)

#### 4.1.1 Assembly summary - radiator/radiator fan, version 1

**1 - Coolant radiator**

- Removing and fitting  
 ⇒ [page 233](#)
- Change coolant after re-  
 newing.

**2 - Coolant hose**

- Lift retaining clip for re-  
 moval
- Connecting  
 ⇒ [page 228](#)

**3 - Not installed**

**4 - Not installed**

**5 - Not installed**

**6 - O-ring**

- Renew following remov-  
 al
- Lubricate with coolant

**7 - Coolant hose**

- Lift the retaining clip to  
 remove
- Connecting  
 ⇒ [page 228](#)

**8 - O-ring**

- Renew following remov-  
 al
- Lubricate with coolant

**9 - Coolant hose**

- Lift the retaining clip to  
 remove
- Connecting  
 ⇒ [page 228](#)

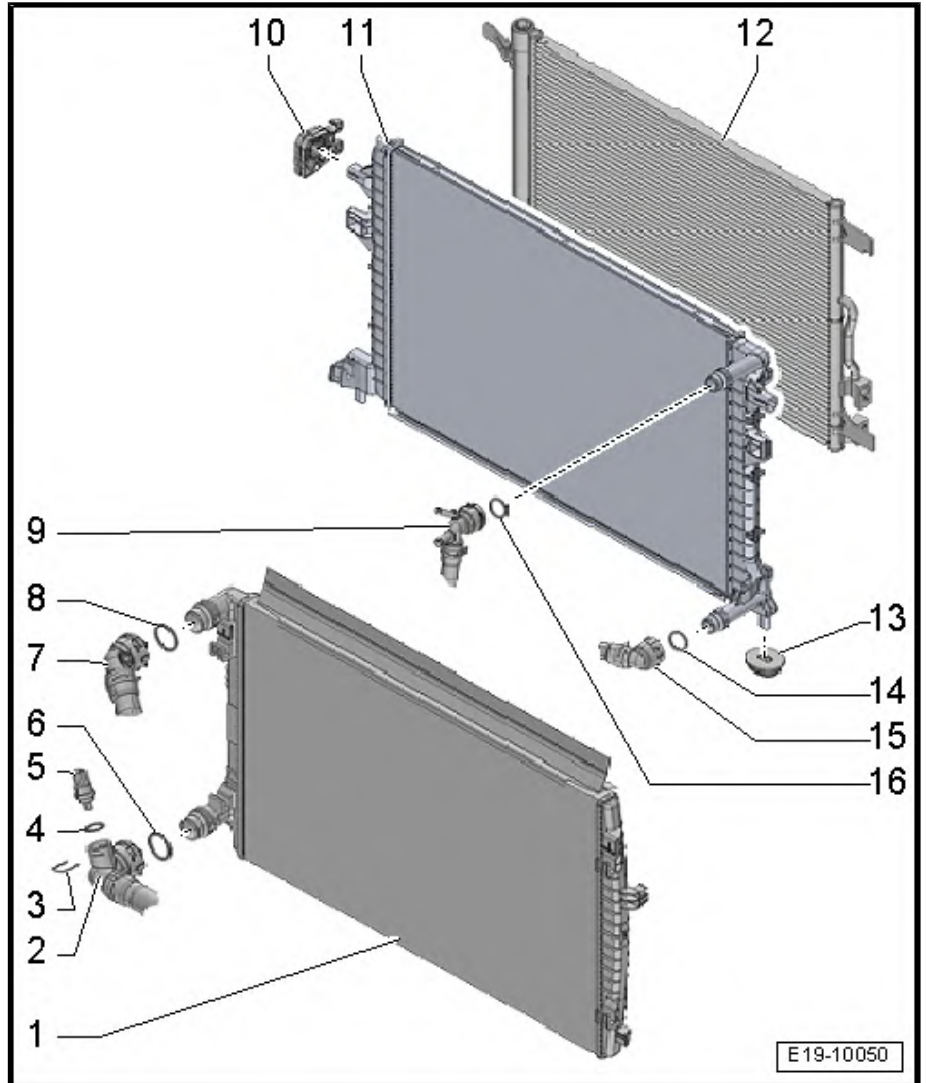

**10 - Radiator mount bracket**

- for radiator

**11 - Water radiator for charge air cooling circuit**

- Removing and fitting ⇒ [“4.4 Removing and positioning radiator”, page 233](#)

**12 - Condenser**

- Removal and installation ⇒ Rep. gr. 87 ; Refrigerant circuit; condenser: removing and installing

**13 - Bonded rubber bush**

- for radiator

**14 - O-ring**

- Renew following removal
- Lubricate with coolant

**15 - Coolant hose**

- Lift retaining clip for removal
- Connecting ⇒ [page 228](#)

**16 - O-ring**

- Renew following removal
- Lubricate with coolant

## 4.1.2 Assembly summary - radiator/radiator fan, version 2

### 1 - Coolant radiator

- Removing and fitting  
⇒ [page 233](#)
- Renew coolant after re-  
newing

### 2 - Coolant hose

- Lift the retaining clip to  
remove
- Connecting  
⇒ [page 228](#)

### 3 - O-ring

- Renew following remov-  
al
- Lubricate with coolant

### 4 - Coolant hose

- Lift the retaining clip to  
remove
- Connecting  
⇒ [page 228](#)

### 5 - O-ring

- Renew following remov-  
al
- Lubricate with coolant

### 6 - Air deflector

### 7 - Air deflector

### 8 - Bonded rubber bush

- for radiator

### 9 - Water radiator for charge air cooling circuit

- Removing and fitting  
⇒ ["4.4 Removing and  
positioning radiator", page 233](#)

### 10 - Condenser

- Removal and installation ⇒ Rep. gr. 87 ; Refrigerant circuit; condenser: removing and installing

### 11 - Bonded rubber bush

- for radiator

### 12 - O-ring

- Renew following removal
- Lubricate with coolant

### 13 - Coolant hose

- lift the retaining clip to remove
- Connecting ⇒ [page 228](#)

### 14 - O-ring

- Renew following removal
- Lubricate with coolant

### 15 - Coolant hose

- Lift the retaining clip to remove

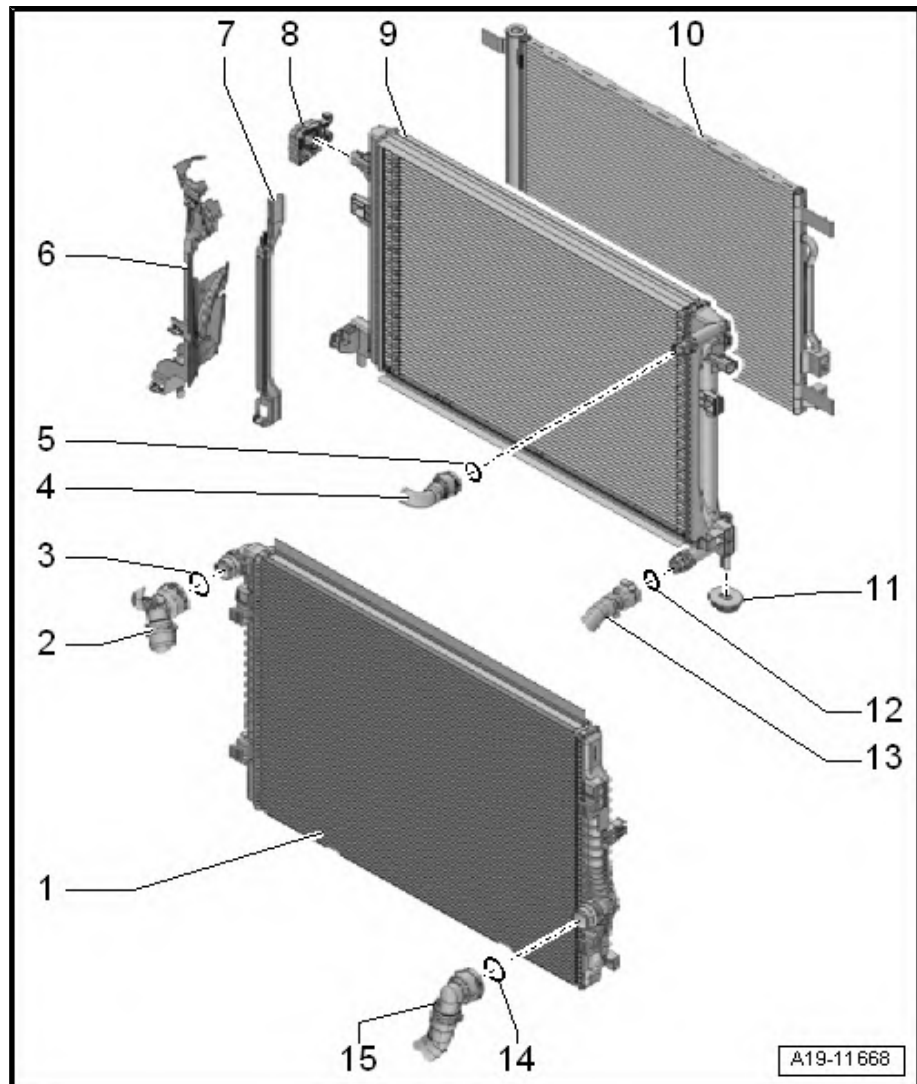

- Connecting ⇒ [page 228](#)

### 4.1.3 Assembly summary - radiator/radiator fan, version 3

#### 1 - Coolant hose

- Lift the retaining clip to remove
- Connecting ⇒ [page 228](#)

#### 2 - O-ring

- Renew following removal
- Lubricate with coolant

#### 3 - Water radiator for charge air cooling circuit

- Removing and installing ⇒ [page 235](#)

#### 4 - Coolant hose

- Lift the retaining clip to remove
- Connecting ⇒ [page 228](#)

#### 5 - O-ring

- Renew following removal
- Lubricate with coolant

#### 6 - Coolant hose

- Lift the retaining clip to remove
- Connecting ⇒ [page 228](#)

#### 7 - O-ring

- Renew following removal
- Lubricate with coolant

#### 8 - Coolant radiator

- Removing and fitting ⇒ [page 235](#)
- Renew coolant after renewing

#### 9 - Air deflector

#### 10 - Air deflector

#### 11 - Condenser

- Removal and installation ⇒ Rep. gr. 87 ; Refrigerant circuit; condenser: removing and installing

#### 12 - Radiator mount bracket

- for radiator

#### 13 - Bonded rubber bush

- for radiator

#### 14 - O-ring

- Renew following removal
- Lubricate with coolant

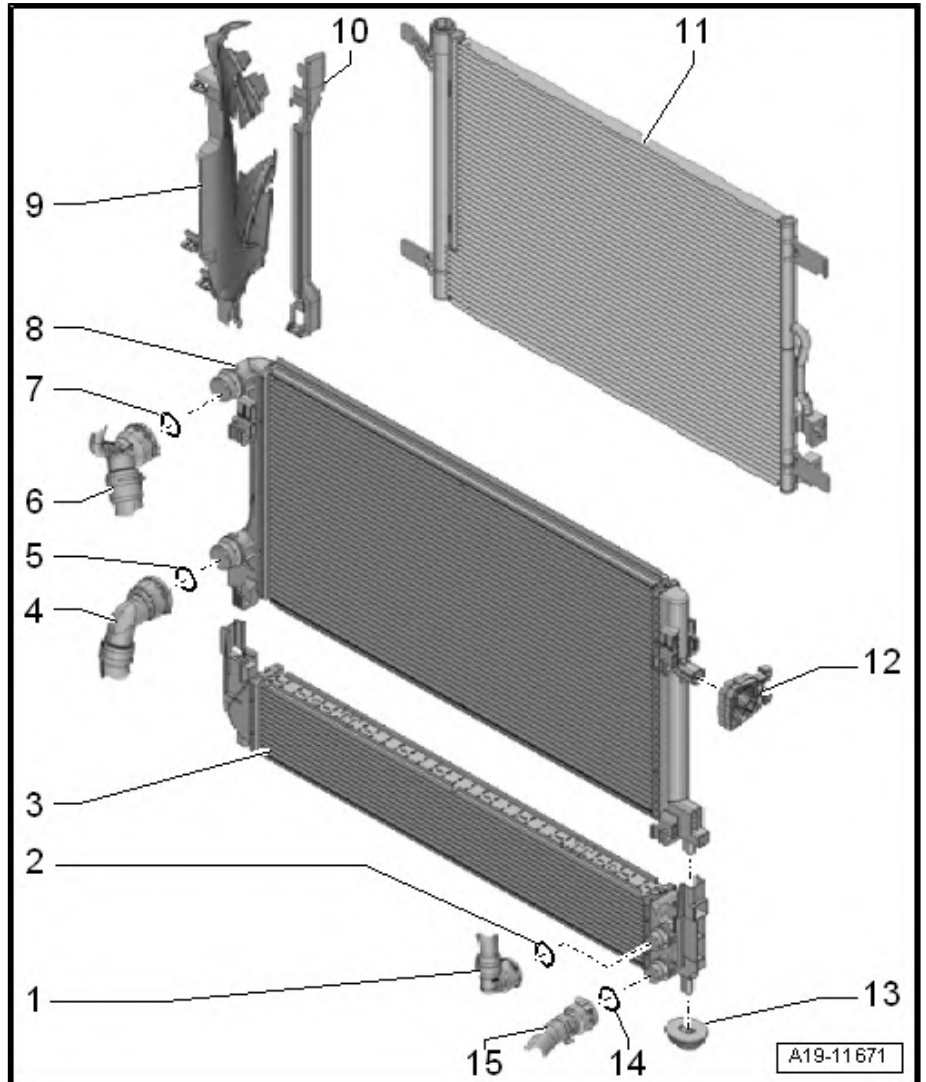

## 15 - Coolant hose

- Lift the retaining clip to remove
- Connecting ⇒ [page 228](#)

### 4.1.4 Plug-in connectors of coolant hoses

#### Connecting coolant hose with plug-in connector to radiator

- Moisten new O-ring with coolant and insert into coolant hose.
- Push coolant hose into connection -1- until it audibly engages.
- Press coolant hose in again and then pull to check that plug-in connector is correctly engaged.

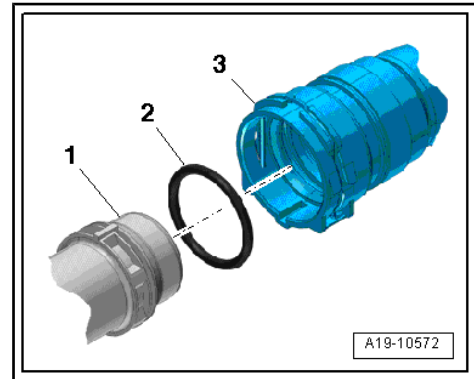

## 4.2 Exploded view - radiator cowl and radiator fans

⇒ [“4.2.1 Assembly overview - radiator cowl with one radiator fan”, page 229](#)

⇒ [“4.2.2 Assembly overview - radiator cowl with two radiator fans”, page 230](#)

### 4.2.1 Assembly overview - radiator cowl with one radiator fan

#### 1 - Bolt.

- 5 Nm

#### 2 - Fan shroud

- Removing and fitting  
⇒ [page 244](#)

#### 3 - Refrigerant fan - V7-

- Removing and fitting  
⇒ [page 244](#)

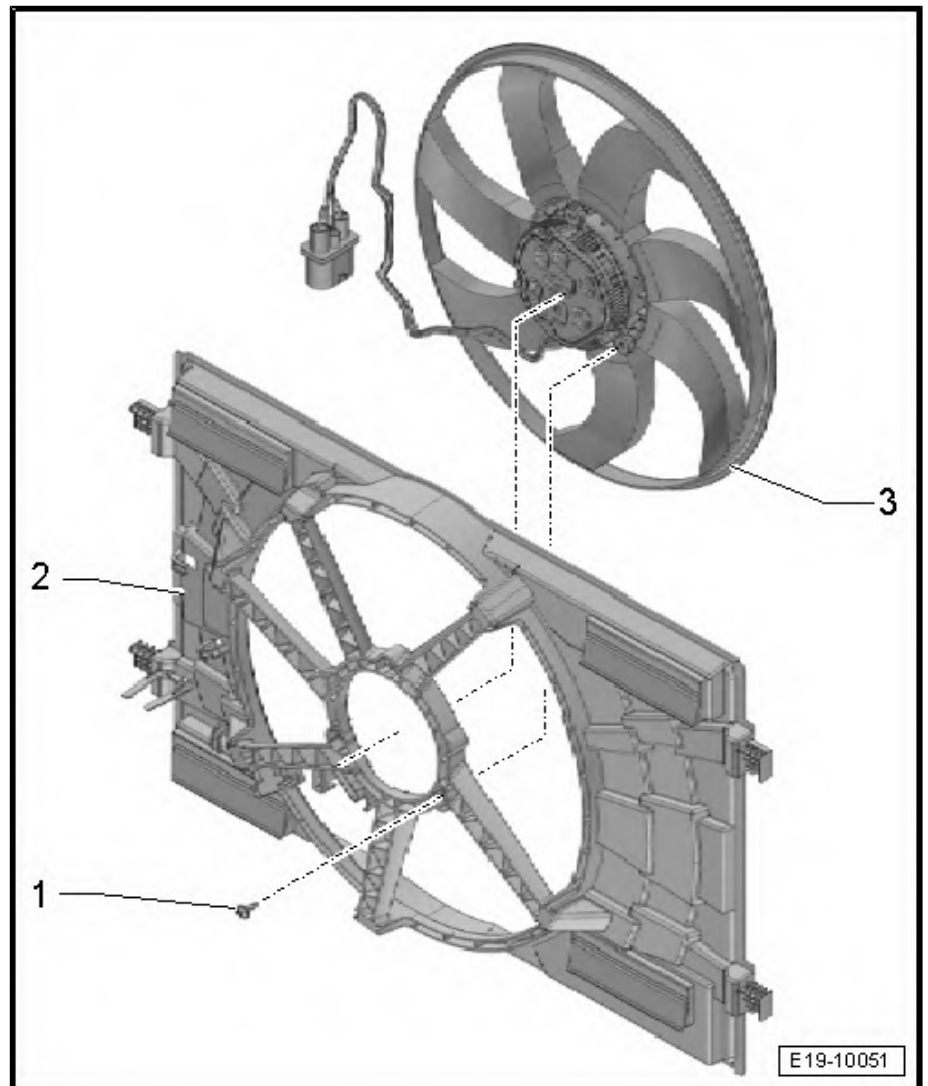

## 4.2.2 Assembly overview - radiator cowl with two radiator fans

### Radiator cowl and radiator fans

- 1 - Bolt.
  - 5 Nm
- 2 - Fan shroud
  - Removing and fitting  
⇒ [page 244](#)
- 3 - Bolt.
  - 5 Nm
- 4 - Refrigerant fan - V7-
  - Removing and fitting  
⇒ [page 244](#)
- 5 - Radiator fan 2 - V177-
  - Removing and fitting  
⇒ [page 244](#)

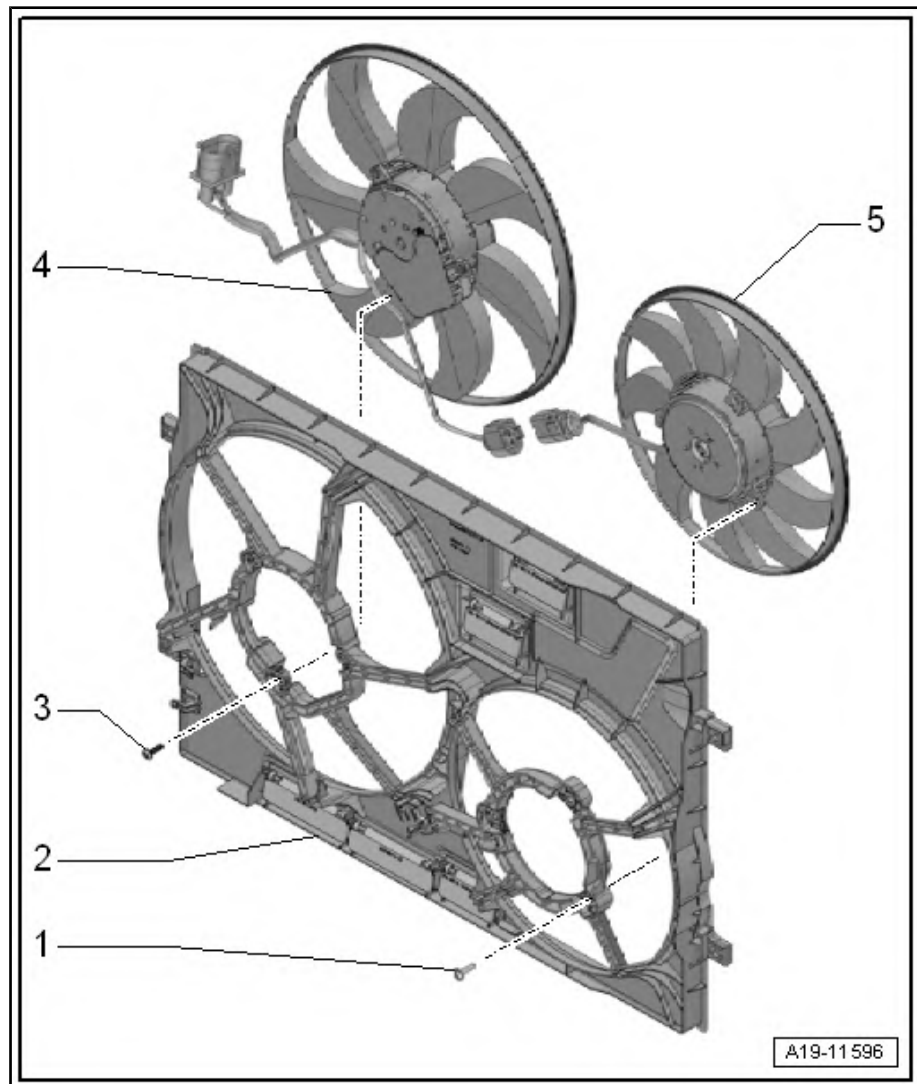

## 4.3 Assembly overview - radiator blind

Assembly overview - radiator blind ⇒ [page 230](#) :

Assembly overview - components of radiator blind ⇒ [page 231](#) :

⇒ Fig. ““Routing cables/lines on radiator blind””, page 233 :

⇒ Fig. ““Arrangement of louvres””, page 232 :

Assembly overview - radiator blind:

### 1 - Bumper carrier

- Assembly overview ⇒  
 General body repairs,  
 exterior; Rep. gr. 50 ;  
 Lock carriers; Assembly  
 overview - Lock carriers

### 2 - Rear seal

### 3 - Radiator blind control motor - V544-

- Removing and installing  
 ⇒ [page 247](#)

### 4 - Retaining tabs

- For seals

### 5 - Ambient temperature sensor - G17-

- Location  
 ⇒ [Item 12 \(page 231\)](#)
- Clipped in on the front seal
- ⇒ Current flow diagrams, Electrical fault finding and Fitting locations

### 6 - Radiator blind

- Removing and installing  
 ⇒ [page 245](#)

### 7 - Connector contact

- For radiator blind control motor - V544-
- Secured to lock carrier
- ⇒ Current flow diagrams, Electrical fault finding and Fitting locations

### 8 - Support bracket

- or securing connector contact to lock carrier ⇒ [Item 7 \(page 231\)](#)

### 9 - Bolt

- 2 pieces
- 8 Nm

### 10 - Wiring harness

- For radiator blind control motor - V544-
- ⇒ Current flow diagrams, Electrical fault finding and Fitting locations

### 11 - Retaining tabs

- For seals

### 12 - Front seal

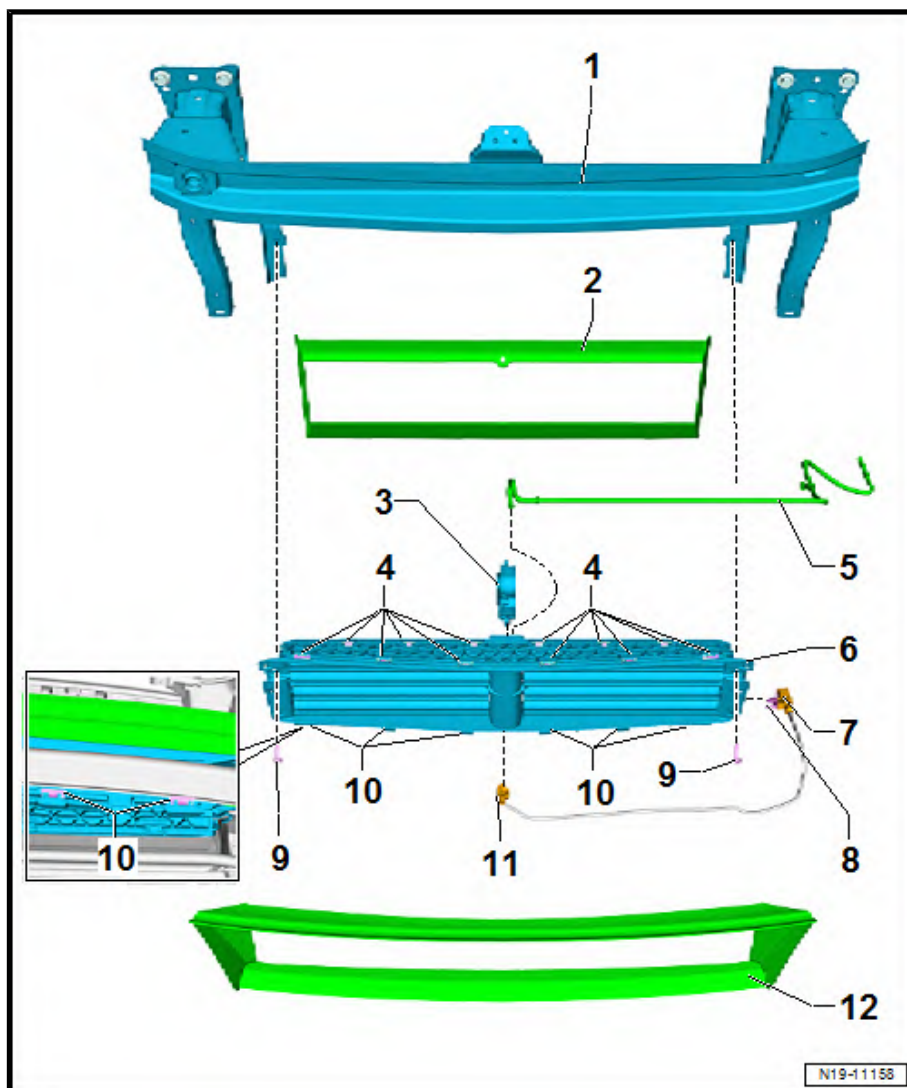

Assembly overview - components of radiator blind:

1 - Connecting link

2 - Bolt

3 - Radiator blind control motor  
- V544-

- Removing and installing  
⇒ [page 247](#)

4 - Flaps

- Note arrangement  
⇒ [page 232](#)

5 - Bolt

6 - Rack

7 - Wiring harness

8 - Engine mounting

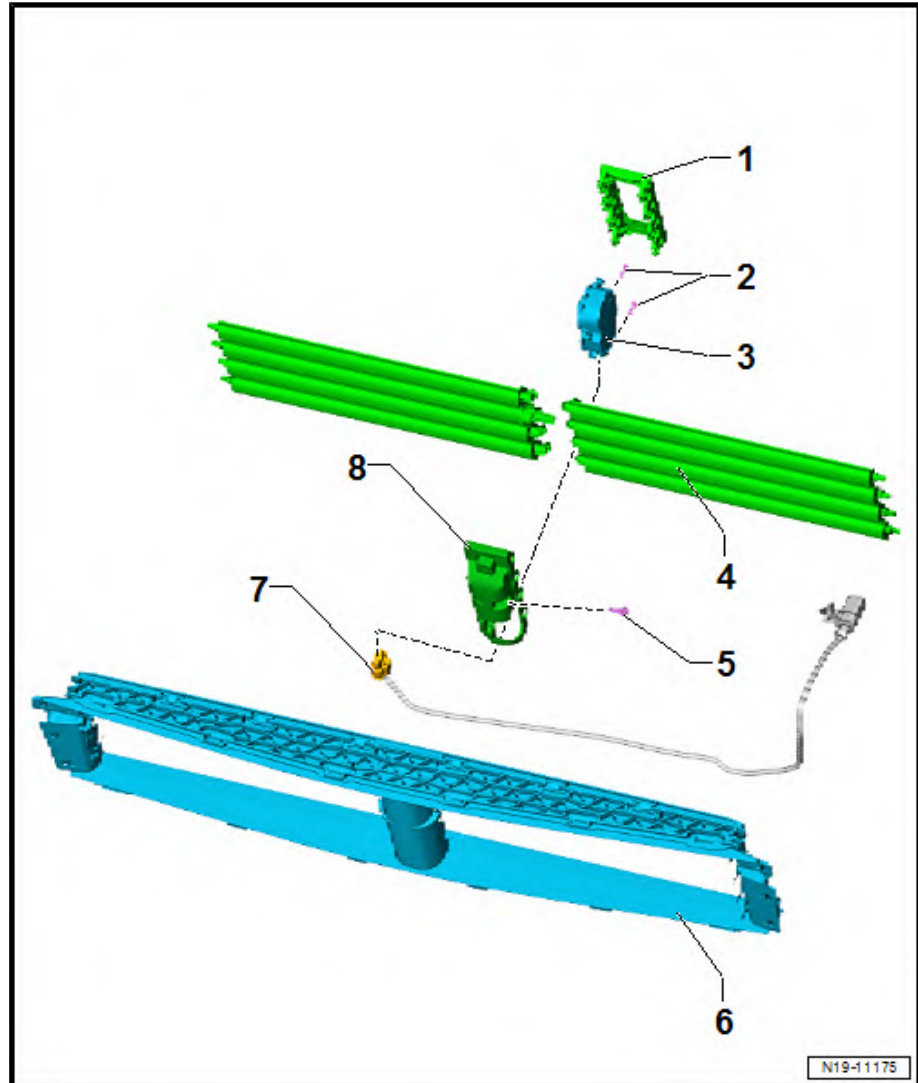

N19-11175

### Arrangement of louvres

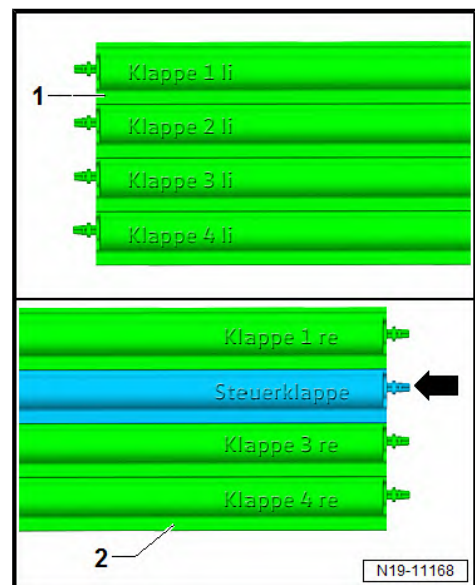

N19-11168

### Routing cables/lines on radiator blind

- Wiring harness -2- of the radiator blind control motor - V544- is clipped into frame of radiator blind -1- -arrows-.

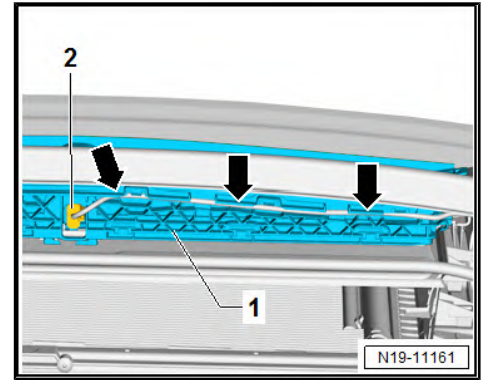

## 4.4 Removing and positioning radiator

⇒ ["4.4.1 Removing and installing radiator, variant 1 and 2 radiators", page 233](#)

⇒ ["4.4.2 Removing and installing radiator, variant 3 radiator", page 235](#)

### 4.4.1 Removing and installing radiator, variant 1 and 2 radiators

Special tools and workshop equipment required

- ◆ Drip tray for workshop hoist - VAS 6208-



- ◆ Wedge - 3409-

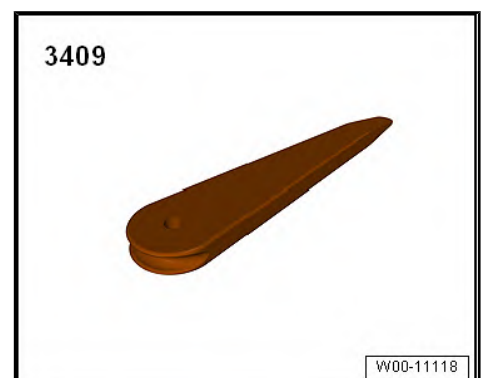

## Removal

- Remove air cleaner housing ⇒ [page 320](#) .
- Drain coolant ⇒ [page 181](#) .
- Lift the retaining clip -arrow-, remove the coolant hose at the top left from the radiator.
- Remove radiator cowl ⇒ [page 244](#) .

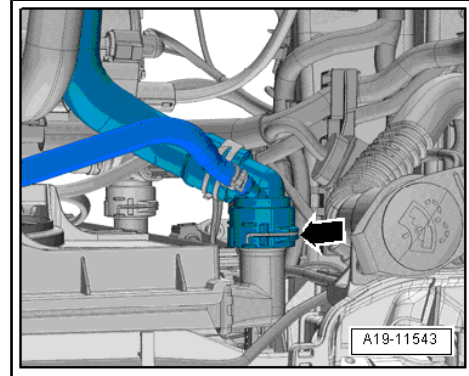

- Use the removal wedge to press both sides of locking tab -1- away from the engine compartment - 3409- and push the radiator -in the direction of the arrow-.
- Pull radiator out of mountings at bottom.
- Remove coolant radiator of the cooler for charge air cooling circuit.
- Remove coolant radiator upwards.

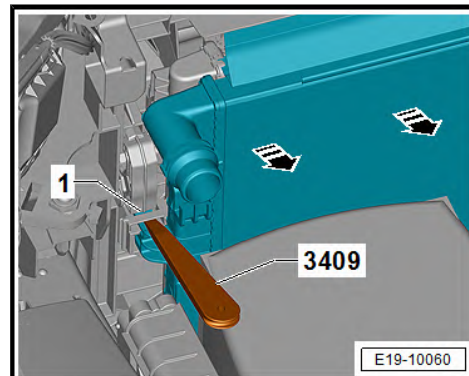

## Installation

Installation is carried out in the reverse order; note the following:



### Note

- ◆ *If there are minor dents in the fins, refer to respective instructions ⇒ [page 14](#) .*
- ◆ *Renew O-rings after removal.*
- Engage radiator in charge air cooler. Ensure proper engagement by pulling.
- Install radiator cowl ⇒ [page 244](#) .
- Connect coolant hose with plug-in connector ⇒ [page 228](#) .
- Replenish coolant ⇒ [page 187](#) .

## Specified torques

- ◆ ⇒ [“4.1 Exploded view - radiator/radiator fans”, page 224](#)
- ◆ ⇒ [“4.1 Exploded view - air cleaner housing”, page 319](#)

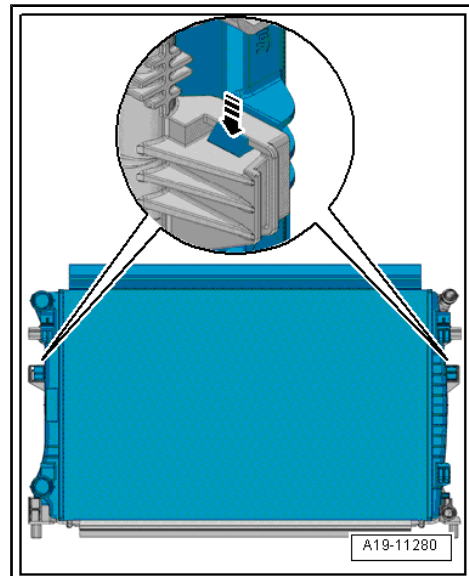

## 4.4.2 Removing and installing radiator, variant 3 radiator

### Note

*Radiator and water radiator for charge air cooling circuit are removed together.*

### Special tools and workshop equipment required

- ◆ Drip tray for workshop hoist - VAS 6208-



- ◆ Wedge - 3409-

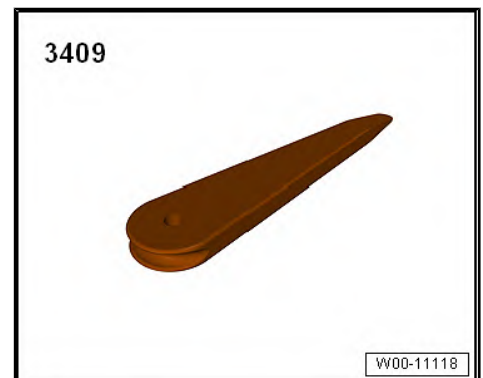

### Removal

- Remove air cleaner housing ⇒ [page 320](#) .
- Drain coolant ⇒ [page 181](#) .
- Lift the retaining clip -arrow-, remove the coolant hose at the top left from the radiator.
- Remove radiator cowl ⇒ [page 244](#) .
- Remove front bumper cover ⇒ General body repairs, exterior; Rep. gr. 63 ; Front bumper; Removing and installing bumper cover .
- Remove the front headlights ⇒ Electrical System; Rep. gr. 94 ; Headlights; Removing and installing headlights

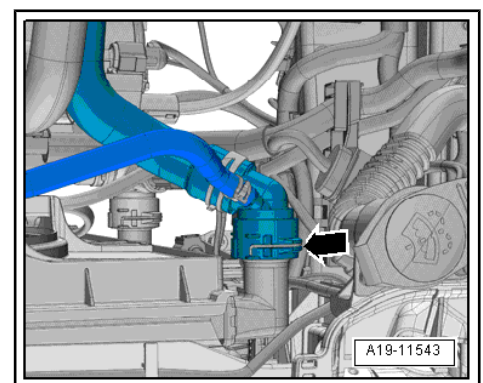

### Vehicles with coolant bearing support, clipped in

- Release catches -arrows- of radiator mounting -1- on left and right, or pinch them off using side cutters.



#### Note

*The radiator mount support is reused during installation. It will then be bolted to lock carrier. Screws => ETKA (electronic spare parts catalogue).*

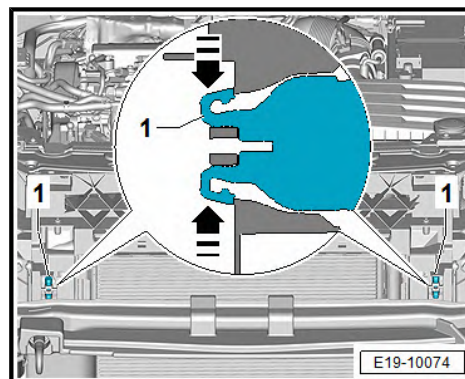

### Vehicles with radiator mounting bracket, screwed on

- Unscrew the screws -2- of the radiator mounting bracket -1- right and left.

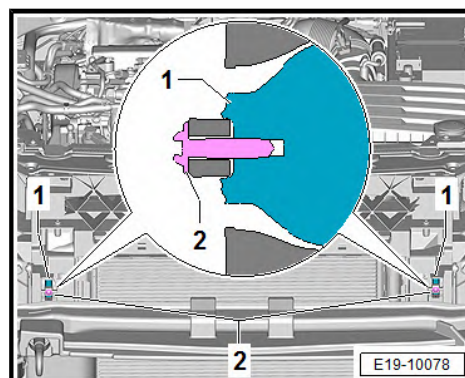

### All vehicles (continued):

- Swivel the radiator on the top edge slightly towards the engine.
- Lift the radiator from the lower supports and press backwards.
- Press catches -1- on both sides in -direction of arrow A- to release them.
- Pull condenser -3- upwards in -direction of arrow B-, and detach it from charge-air cooler -2-.
- Secure condenser fixed to lock carrier.

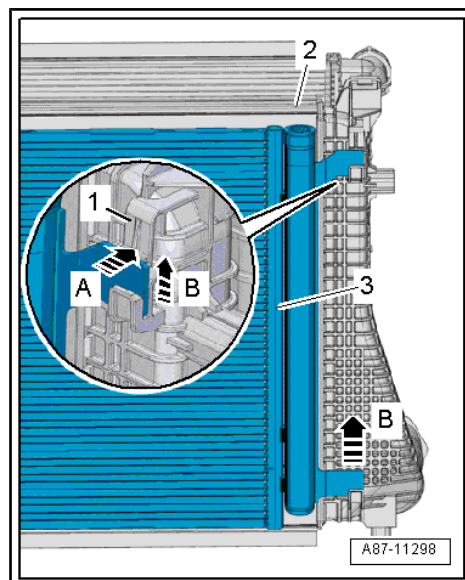

- Lift radiator module -1- at bottom out of radiator mountings -arrows-.
- Detach both radiators.

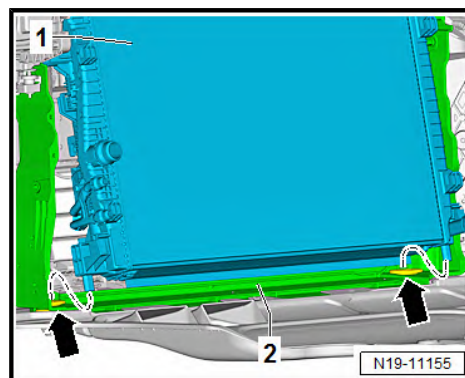

- If required, unlock the intended catches on the cooler -1- for charge-air coolant circulation -arrows A-.
- Remove the water radiator for charge air cooling circuit from the radiator -2- for coolant -arrow B- and unhook it -arrow C-.

### Installation

Installation is carried out in the reverse order; note the following:

#### Note

- ◆ *If there are minor dents in the fins, refer to respective instructions => [page 14](#) .*
- ◆ *Renew O-rings after removal.*
- Engage radiator in charge air cooler. Ensure proper engagement by pulling.
- Insert radiator module -1- at bottom into radiator mountings -arrows-.

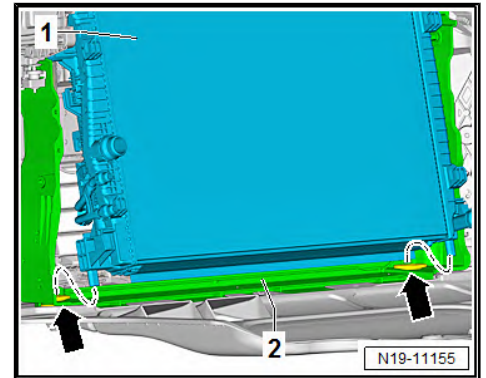
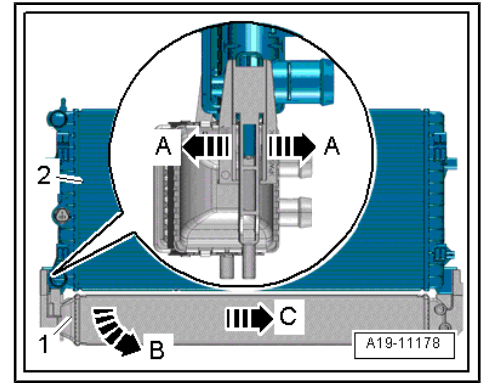

- Place the condenser -3- in the installation position.

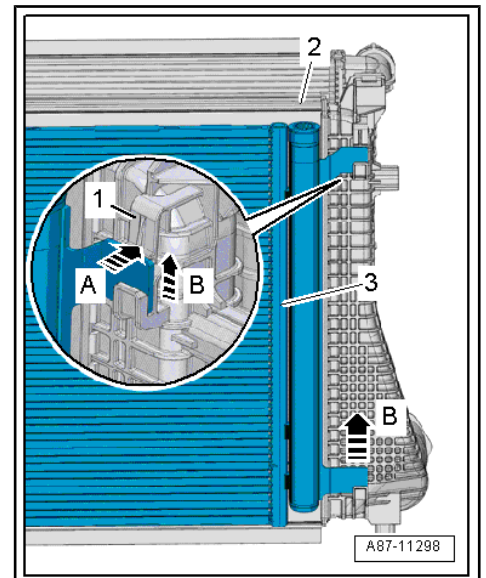

### Installation position of the radiator mounting bracket

- Fit radiator mountings -1- on left and right onto radiator. When doing so, note the installation position -arrow-.

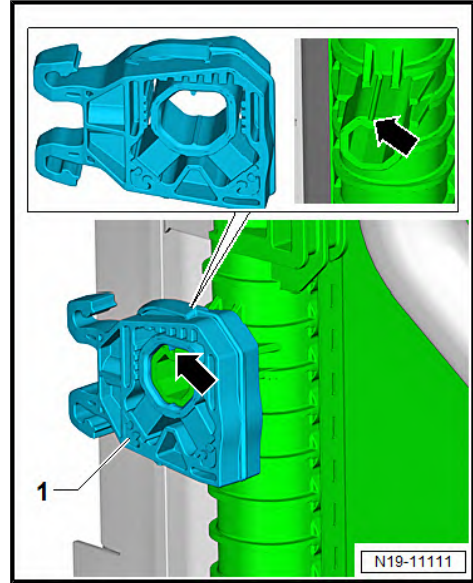

- Swing water radiator for charge air cooling circuit into lock carrier. Ensure proper seating of radiator mountings -1- in lock carrier.

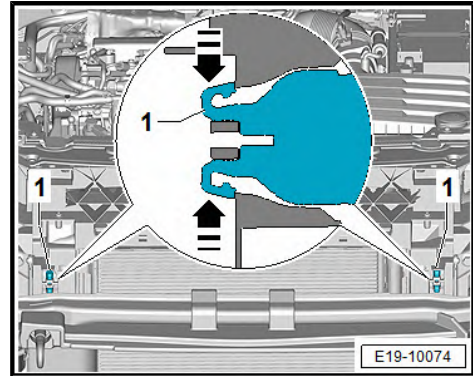

### Vehicles with radiator mounting bracket, screwed on

- Tighten coolant bearing with pinched off catches on the lock carrier. Screws -2- ⇒ ETKA (electronic spare parts catalogue) .
- Tightening torque: 5 Nm

### All vehicles (continued):

- Install the headlights ⇒ Electrical System; Rep. gr. 94 ; Headlights; Assembly overview - Headlights .
- Install front bumper cover ⇒ General body repairs, exterior; Rep. gr. 63 ; Front bumper; Removing and installing front bumper .
- Install radiator cowl ⇒ [page 244](#) .
- Connect coolant hose with plug-in connector ⇒ [page 228](#) .
- Replenish coolant ⇒ [page 187](#) .

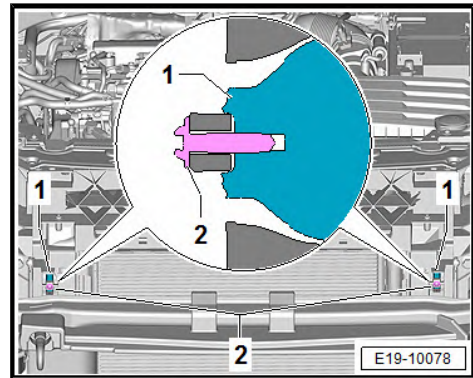

### Specified torques

- ◆ ⇒ [“4.1 Exploded view - radiator/radiator fans”, page 224](#)
- ◆ ⇒ [“4.1 Exploded view - air cleaner housing”, page 319](#)

## 4.5 Removing and installing cooler for charge air cooling circuit

⇒ ["4.5.1 Removing and installing cooler for charge air cooling circuit, variants 1 and 2"](#), page 239

⇒ ["4.5.2 Removing and installing charge-air cooling circuit, version 3"](#), page 243

### 4.5.1 Removing and installing cooler for charge air cooling circuit, variants 1 and 2

Special tools and workshop equipment required

◆ Drip tray for workshop hoist - VAS 6208-



◆ Wedge - 3409-

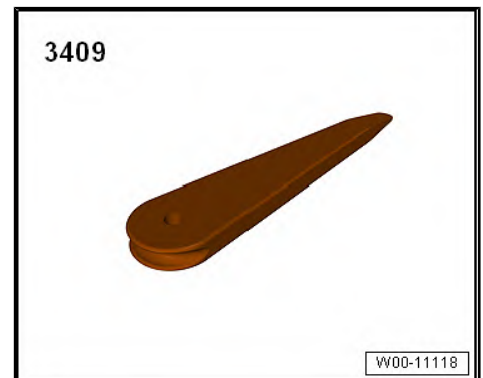

#### Removal

- Remove air cleaner housing ⇒ [page 320](#) .
- Drain coolant ⇒ [page 181](#) .
- Lift the retaining clip -arrow-, remove the coolant hose at the top left from the radiator.

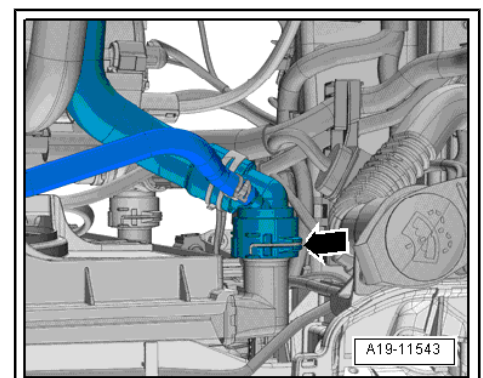

- Lift retaining clip -arrow-, and remove upper right coolant hose from water radiator for charge air cooling circuit.
- Remove radiator cowl ⇒ [page 244](#) .

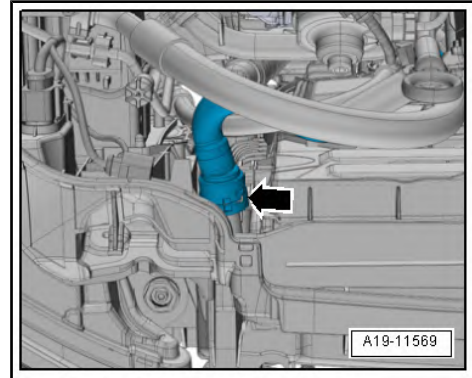

- Use the removal wedge to press both sides of locking tab -1- away from the engine compartment - 3409- and push the radiator -in the direction of the arrow-.
- Pull radiator out of mountings at bottom.
- Remove radiator from water radiator for charge air cooling circuit.
- Remove coolant radiator upwards.
- Remove front bumper cover ⇒ General body repairs, exterior; Rep. gr. 63 ; Front bumper; Removing and installing bumper cover .
- Remove headlight ⇒ Electrical system; Rep. gr. 94 ; Removing and installing headlights .

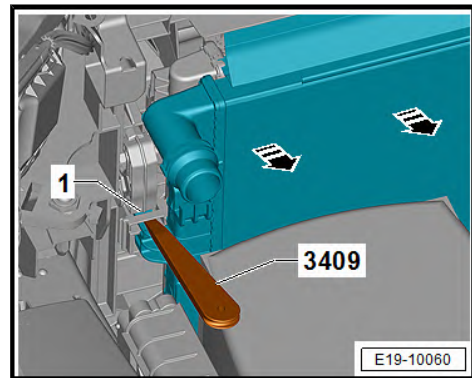

#### Vehicles with coolant bearing support, clipped in

- Release catches -arrows- of radiator mounting -1- on left and right, or pinch them off using side cutters.



#### Note

*The radiator mount support is reused during installation. It will then be bolted to lock carrier. Screws ⇒ ETKA (electronic spare parts catalogue) .*

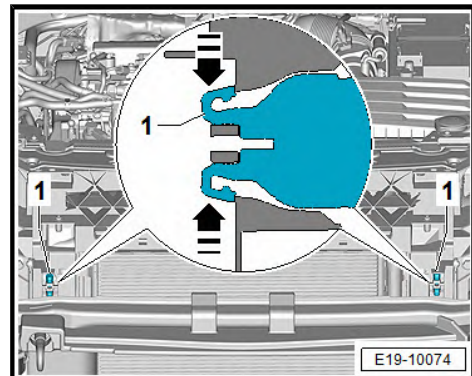

#### Vehicles with radiator mounting bracket, screwed on

- Unscrew the screws -2- of the radiator mounting bracket -1- right and left.

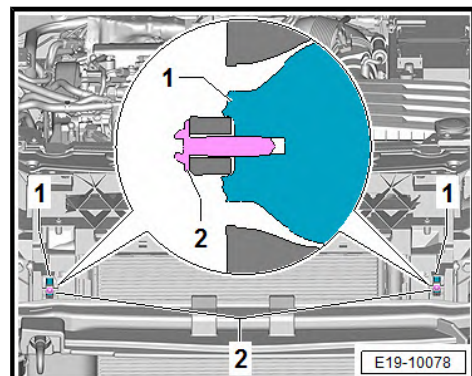

**All vehicles (continued):**

- Swivel the radiator on the top edge slightly towards the engine.
- Lift the radiator from the lower supports and press backwards.
- Press catches -1- on both sides in -direction of arrow A- to release them.
- Pull condenser -3- upwards in -direction of arrow B-, and detach it from charge-air cooler -2-.
- Secure condenser fixed to lock carrier.

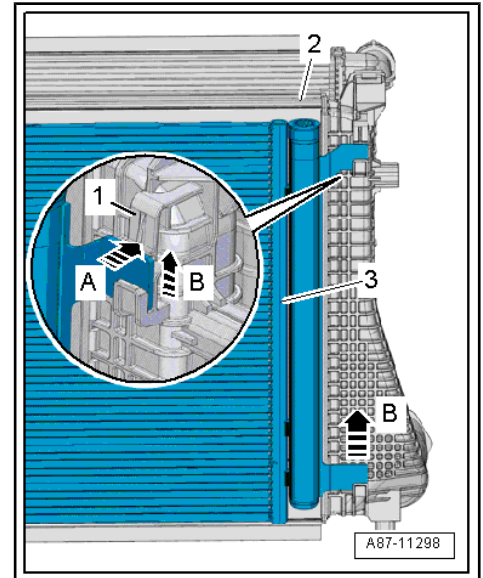

- Remove radiator for charge-air cooler -1- at bottom from the radiator mountings -arrows-.
- Remove radiator for charge-air cooler -1-.

**Installation**

Installation is carried out in the reverse order; note the following:

**i Note**

- ◆ *If there are minor dents in the fins, refer to respective instructions => page 14 .*
- ◆ *Renew O-rings after removal.*

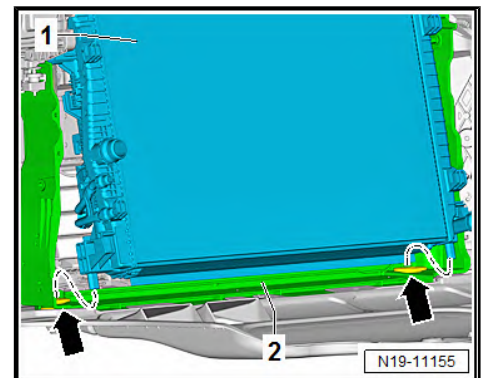

- Engage radiator in charge air cooler. Ensure proper engagement by pulling.

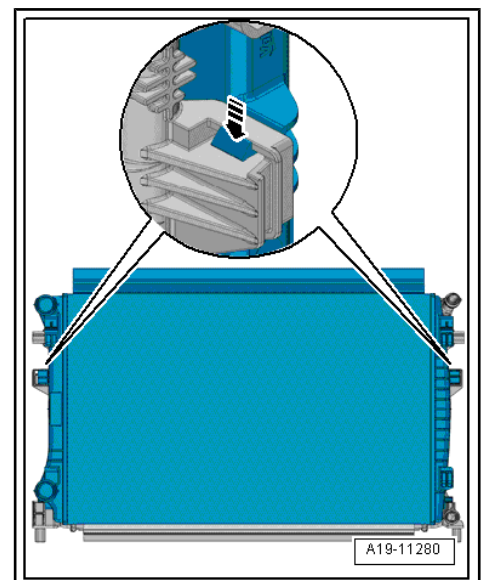

- Insert radiator module -1- at bottom into radiator mountings -arrows-.

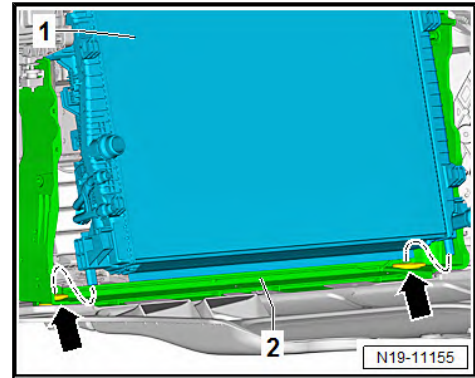

- Place the condenser -3- in the installation position.

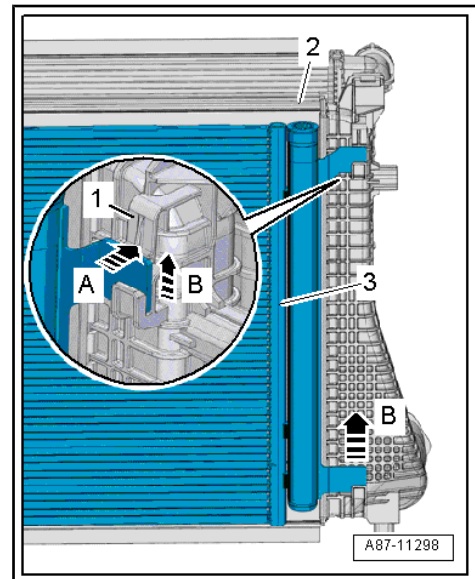

#### Installation position of the radiator mounting bracket

- Fit radiator mountings -1- on left and right onto radiator. When doing so, note the installation position -arrow-.

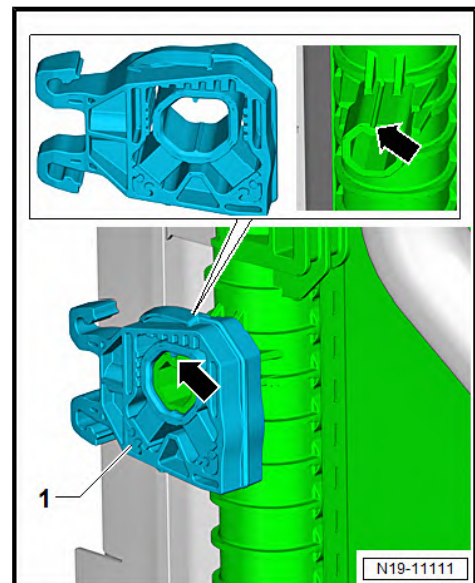

- Swing water radiator for charge air cooling circuit into lock carrier. Ensure proper seating of radiator mountings -1- in lock carrier.

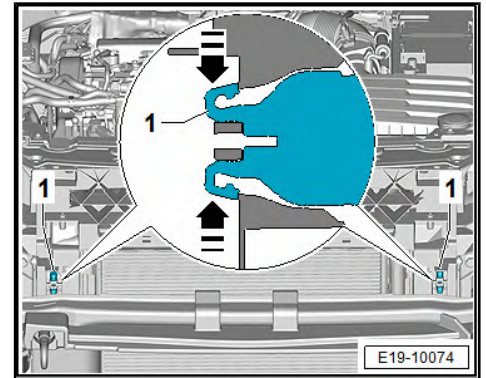

#### Vehicles with radiator mounting bracket, screwed on

- Tighten coolant bearing with pinched off catches on the lock carrier. Screws -2- → ETKA (electronic spare parts catalogue) .
- Tightening torque: 5 Nm

#### All vehicles (continued):

- Install the front headlights ⇒ Electrical System; Rep. gr. 94 ; Headlights; Assembly overview - Headlights .
- Install the front bumper cover ⇒ General body repairs, exterior; Rep. gr. 63 ; Front bumper; Remove and install front bumper cover .
- Install radiator cowl ⇒ [page 244](#) .
- Connect coolant hose with plug-in connector ⇒ [page 228](#) .
- Replenish coolant ⇒ [page 184](#) .

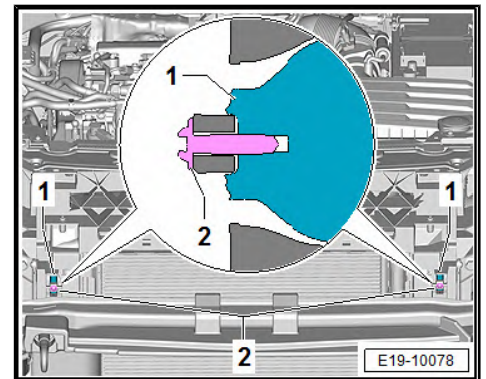

#### Specified torques

- ◆ ⇒ General body repairs, exterior; Rep. gr. 63 ; Front bumper; Removing and installing bumper cover
- ◆ ⇒ [“4.1 Exploded view - radiator/radiator fans”, page 224](#)
- ◆ ⇒ [“4.1 Exploded view - air cleaner housing”, page 319](#)

### 4.5.2 Removing and installing charge-air cooling circuit, version 3



#### Note

- ◆ *Radiator and water radiator for charge air cooling circuit are removed together.*
- ◆ *Removing and installing radiator ⇒ [page 235](#) .*

## 4.6 Removing and installing radiator cowl with radiator fan

### Removal

- Remove air cleaner housing ⇒ [page 320](#) .
- Free coolant hose -3-.
- Remove screws -1-.
- Release locking lugs-arrow-, unclip air hose -2- from the front end and remove in -direction of the arrow-.
- Remove noise insulation ⇒ General body repairs, exterior; Rep. gr. 63 ; Front bumper; Remove and install front bumper cover .

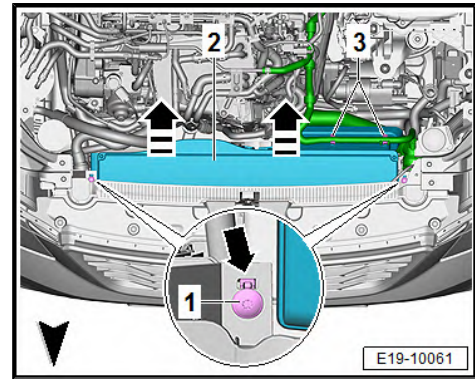

### WARNING

*Danger of injury; the radiator fans can run at any time.*

- ◆ *Unplug electrical connectors before starting to work in the area of radiator cowl.*

- Unplug electrical connector -1- for radiator fan (push retainer in direction of -arrow A- and press release catch down).
- Press locking tabs on left and right sides of radiator cowl simultaneously -arrow B- and detach radiator cowl downwards from radiator.

### Installation

Installation is carried out in the reverse order; note the following:

### Specified torques

- ◆ Remove and install noise insulation ⇒ General body repairs, exterior; Rep. gr. 66 ; Noise insulation; Assembly overview - Noise insulation .

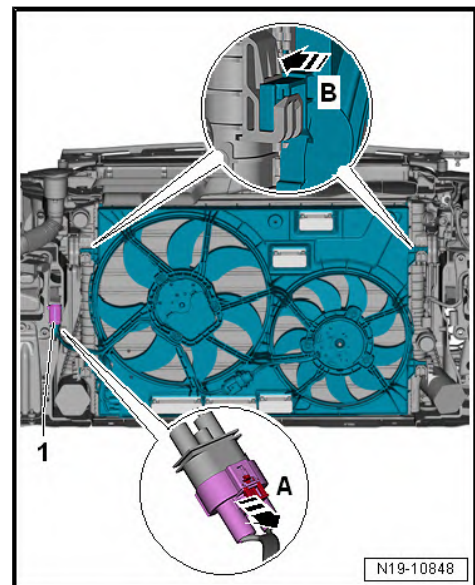

## 4.7 Removing and installing radiator fans

⇒ ["4.7.1 Removing and installing radiator fan V7"](#) , [page 244](#)

⇒ ["4.7.2 Removing and installing radiator fan V177"](#) , [page 245](#)

### 4.7.1 Removing and installing radiator fan - V7-

#### Removal



#### Note

*When fitting, attach all cable ties back to the same location.*

- Remove radiator cowl ⇒ [page 244](#) .

- Unplug electrical connector.
- Unscrew bolts -1- and remove radiator fan - V7- .

#### Installation

Installation is carried out in the reverse order; note the following:

- Install radiator cowl ⇒ [page 244](#) .

#### Specified torques

- ◆ ⇒ [“4.2 Exploded view - radiator cowl and radiator fans”, page 229](#)

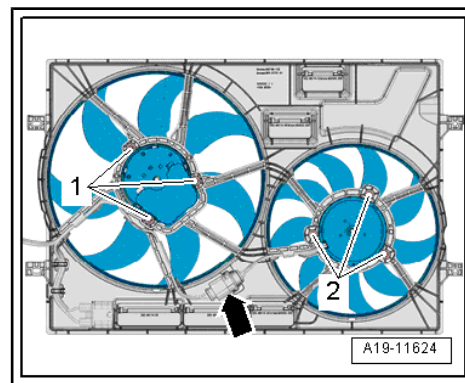

### 4.7.2 Removing and installing radiator fan - V177-

#### Removal



#### Note

*When fitting, attach all cable ties back to the same location.*

- Remove radiator cowl ⇒ [page 244](#) .
- Unplug electrical connector.
- Unscrew bolts -2- and remove radiator fan - V177- .

#### Installation

Installation is carried out in the reverse order; note the following:

- Install radiator cowl ⇒ [page 244](#) .

#### Specified torques

- ◆ ⇒ [“4.2 Exploded view - radiator cowl and radiator fans”, page 229](#)

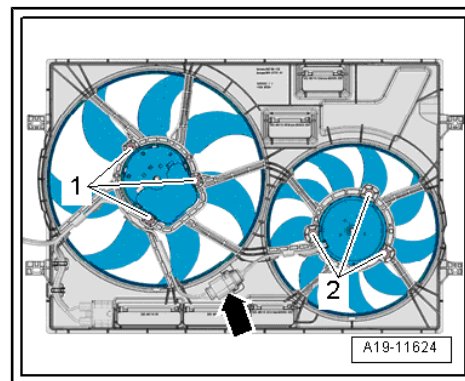

### 4.8 Removing and installing radiator blind

#### Special tools and workshop equipment required

- ◆ Pressing-off lever - 80 - 200-

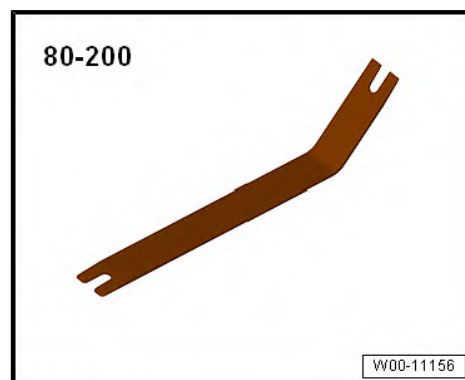

◆ Wedge - 3409-



**Removing:.**

- Remove noise insulation ⇒ Rep. gr. 66 ; Noise insulation; Removing and installing noise insulation .
- Remove front bumper cover ⇒ General body repairs, exterior; Rep. gr. 63 ; Front bumper; Removing and installing front bumper cover .
- Release and disconnect the electrical connectors -2- and -3-.
- Unclip the recess -arrows- on the front end -1-.

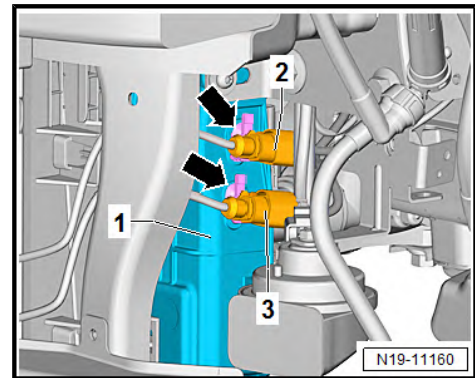

- Remove bolts -arrows-.
- Pull off the radiator blind -1- with the seal forwards.
- Secure the radiator blind -1-, to ensure it does not fall down.

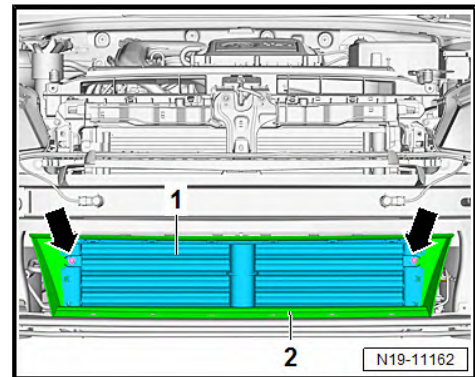

- Unclip the seal -2- from the lug -arrows-.
- Pull seal -2- off radiator blind -1-.
- Remove the radiator blind -1- downwards.

**Fitting:**

Install analogously in reverse order, but please note the following.

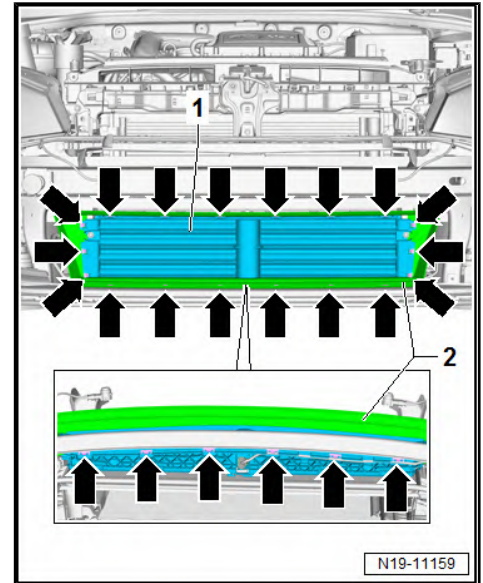

- Make sure that the guides of radiator blind -2- are properly seated on bumper carrier -1- -arrow-.
- After replacing radiator blind, a basic setting must be performed.
- Use => Vehicle diagnostic tester.
- Erase event memory => Vehicle diagnostic tester.
- Connect vehicle diagnostic tester and follow path to basic setting.

Self-diagnosis-capable systems

0001 - Engine electronics

0001 - Diesel engine 1.4 - 2.0 litres - J623

Select 0001 - Direct diesel injection and diesel pre-heating system EDC 17 .

0001 - Engine electronics, functions

0001 - Basic setting

0001 - Radiator blind control motor adaption - V544

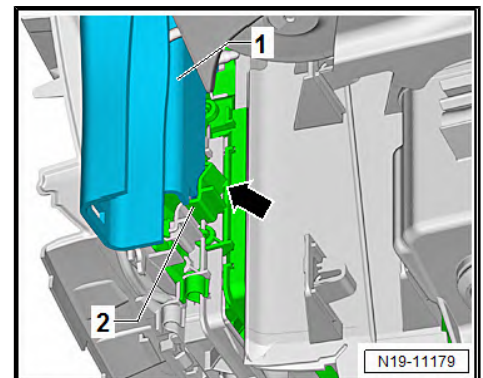

## 4.9 Removing and installing radiator blind control motor - V544-

- Remove radiator blind => [page 245](#) .

- Unclip the seal -2- from the top and bottom lugs -arrows-.
- Pull seal -2- off radiator blind -1-.

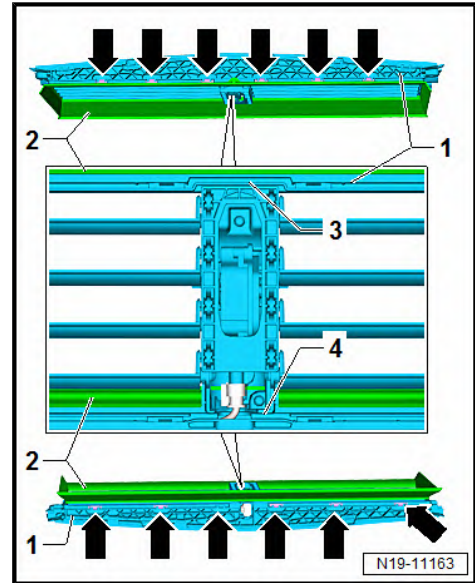

- Unclip the seal -2- from the left and right lugs -arrows-.
- Pull seal -2- off radiator blind -1-.

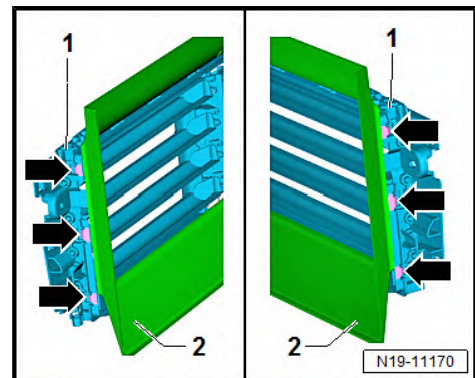

- Position the flaps of the radiator blind to open as shown in the illustration.
- To do this, move connecting piece -1-.
- Release and unplug electrical connector -3-.
- Remove bolts -arrows-.

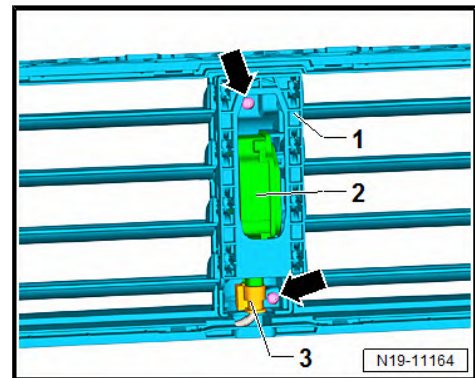

- Lift the radiator blind control motor - V544- with flaps upwards out of motor mounting => Item 3 (page 232) .
- Push the radiator blind control motor - V544- with flaps -2- as far to the left as possible -arrow B-.

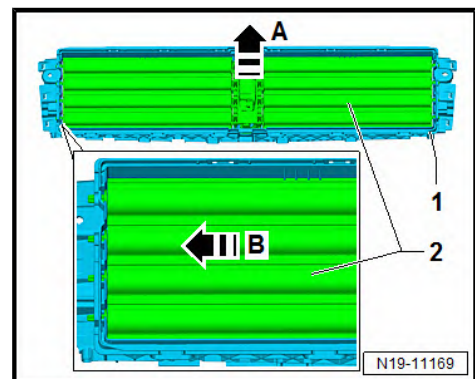

- Lever flaps -2- on right side out of frame -1-.

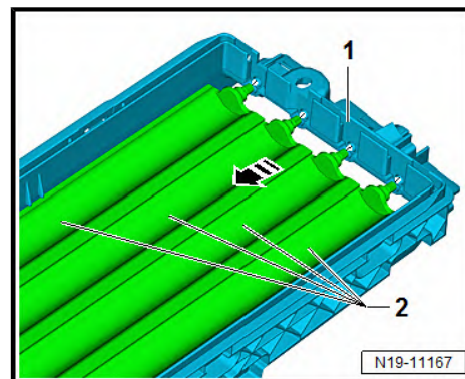

- Mark installation position of connecting piece -1-.
- Use connector contact -5- as a reference.
- Lever the connecting piece -1- off guide rollers -3- and -4- of flaps -2- and remove.

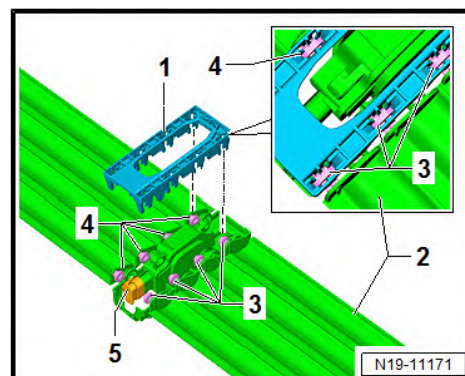

- Pull the control flap -1- off radiator blind control motor - V544- -2-.
- To do this, release retaining clips -arrow-.

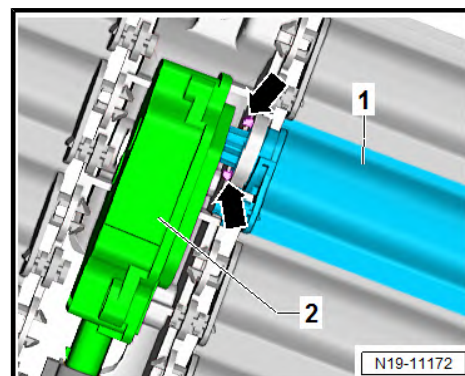

- If fitted, unscrew bolt -3-.
- Carefully swing the radiator blind control motor - V544- upwards in -direction of arrow-.
- Pull radiator blind control motor - V544- off pin -4-.
- If necessary, release flaps on motor mounting, and remove them => [Item 8 \(page 232\)](#) .

### Installation

Install analogously in reverse order, but please note the following.

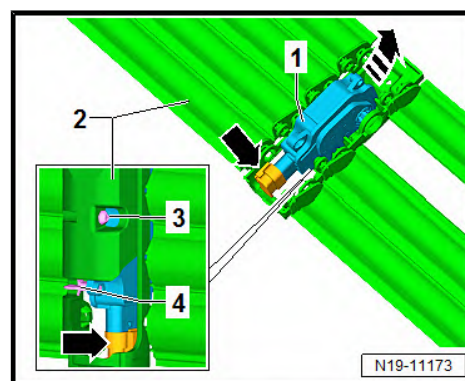

- Insert flaps -1- through -8- as shown in illustration, and engage them.
- Insert control flap -6-, and engage it.
- Note position of connector contact -arrow- when installing. The electric connector must point downwards.
- Note arrangement of flaps. The flaps are located on top of one another.
- The upper flaps rest on the flaps located below them.

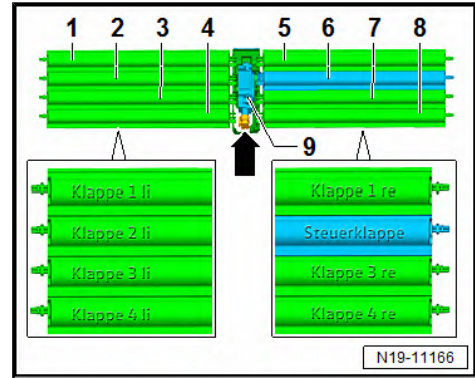

Serial	Flaps left side	Serial	Flaps right side
1	Flap 1, left	5	Flap 1, right
2	Flap 2, left	6	Control flap
3	Flap 3, left	7	Flap 3, right
4	Flap 4, left	8	Flap 4, right

- Fit connecting piece -1- in correct installation position.
- Use the marking made beforehand or the connector contact -arrow- as a reference.
- Make sure that the connecting piece is properly seated on guide rollers.
- Insert flaps with radiator blind control motor - V544- into frame.
- Bolt on the radiator blind control motor - V544- , and connect connector.

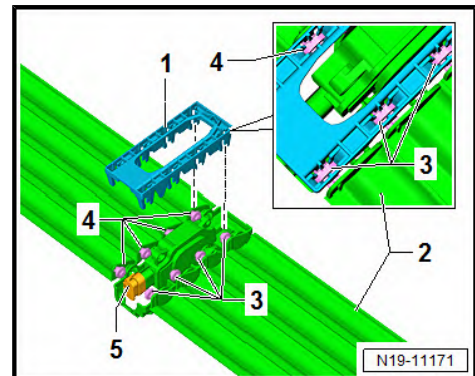

- Insert radiator blind control motor - V544- with flaps into frame -1-.
- Make sure that the flaps of the radiator blind control motor - V544- are properly seated in mountings -arrows-.

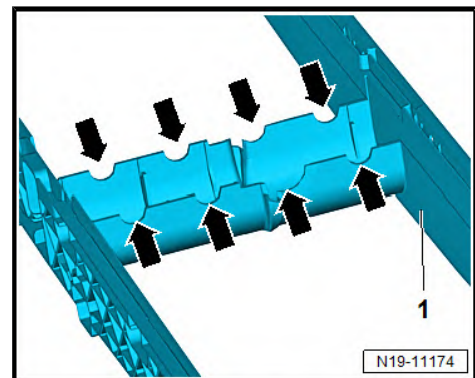

- Connect the electrical connector -2-.
- Clip in wiring harness -arrows-.

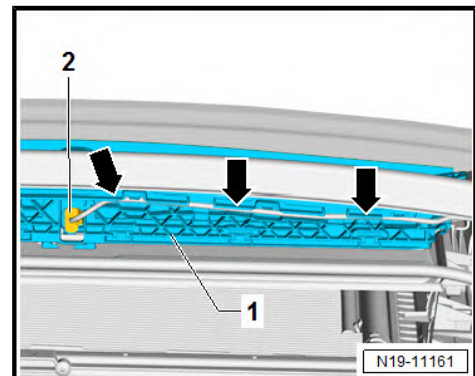

- Fit seal -2- to frame of radiator blind -1-.
- Note the position of installation on recesses -3- and -4-.
- Clip in seal -2-.
- After replacing radiator blind control motor - V544- , a basic setting must be performed.
- Use ⇒ Vehicle diagnostic tester.
- Erase event memory ⇒ Vehicle diagnostic tester.
- Connect vehicle diagnostic tester and follow path to basic setting.

Self-diagnosis-capable systems

0001 - Engine electronics

0001 - Diesel engine 1.4 - 2.0 litres - J623

Select 0001 - Direct diesel injection and diesel pre-heating system EDC 17 .]

0001 - Engine electronics, functions

0001 - Basic setting

0001 - Radiator blind control motor adaption - V544

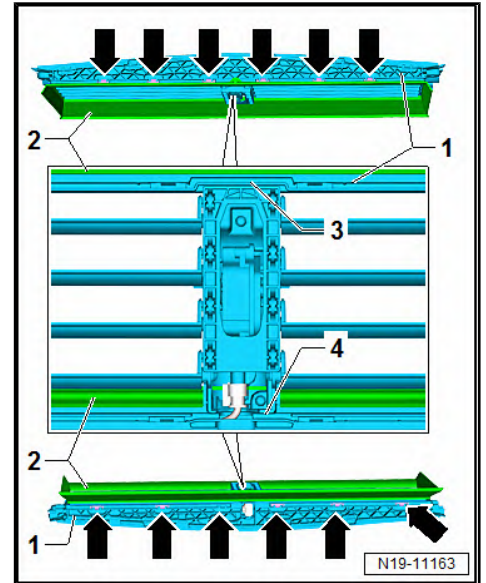

## 21 – Turbocharging/supercharging

### 1 Exhaust turbocharger

⇒ “1.1 Exploded view - turbocharger”, page 252

⇒ “1.2 Turbo compressor: removing and fitting”, page 254

⇒ “1.3 Renewing vacuum unit for turbocharger”, page 270

⇒ “1.4 Removing and installing connection for turbocharger”, page 274

#### 1.1 Exploded view - turbocharger

**1 - Hollow bolt**

- 30 Nm

**2 - Oil supply line**

- Check for obstructions
- Before installing, fill turbocharger with engine oil at oil supply line connection.

**3 - Bolt.**

- 12 Nm

**4 - Connection nut**

- 22 Nm

**5 - Exhaust gas temperature sender 1 - G235-**

- Assembly overview ⇒ page 411

**6 - Bolt.**

- Tightening torque and sequence ⇒ page 253 .

**7 - Bolt.**

- 15 Nm

**8 - Heat shield**

**9 - O-ring**

- Renew following removal

**10 - Pulsation damper**

**11 - Bolt.**

- 8 Nm

**12 - Connection**

**13 - Bolt.**

- 8 Nm

**14 - O-ring**

- Renew following removal

**15 - Bracket/bearing/support**

- For electrical wiring

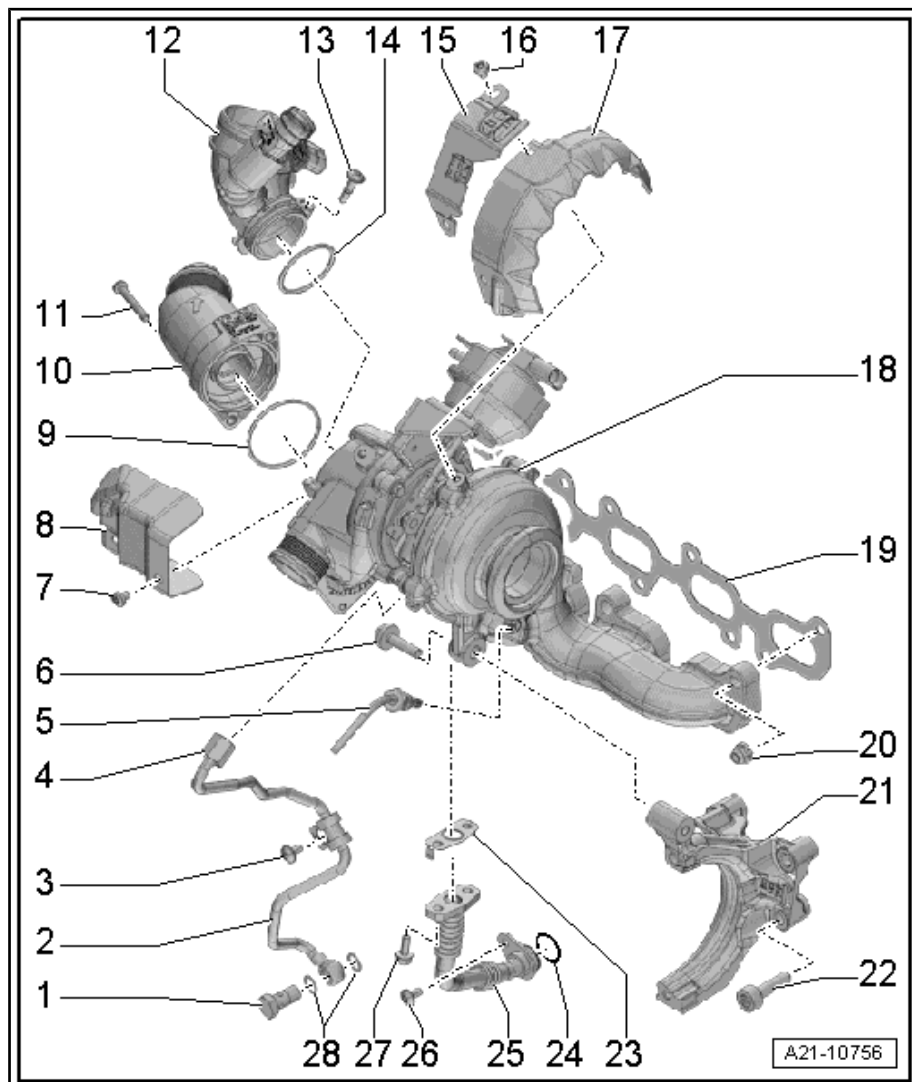

**16 - Bolt.**

- 15 Nm

**17 - Heat shield**

**18 - Exhaust turbocharger**

- Removing and fitting ⇒ [page 254](#)

**19 - Seal**

- Renew following removal

**20 - Nut**

- Renew following removal
- Tightening torque and sequence ⇒ [page 254](#) .

**21 - Bracket/bearing/support**

- For emission control module

**22 - Bolt.**

Tightening torque and sequence ⇒ [page 253](#) .

**23 - Seal**

- Renew following removal

**24 - O-ring**

- Renew following removal
- Lubricate lightly with engine oil

**25 - Oil return pipe**

**26 - Bolt.**

- 10 Nm

**27 - Ribbed bolt**

- 14 Nm

**28 - Sealing rings**

- Renew following removal

**Bracket for emission control module - tightening torque and tightening sequence**

- Fit bracket in correct installation position.
- Tighten bolts in stages in the sequence given:

stage	Bolts	Tightening torque
1st	-1, 2, 3, 4-	Screw in by hand until they make contact
2nd	-2-	20 Nm
3.	-1-	40 Nm
4.	-3, 4-	40 Nm

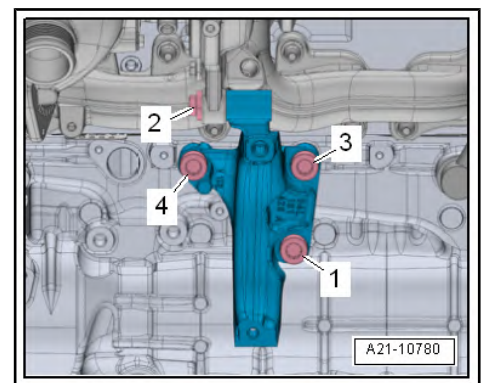

### Turbocharger - tightening torque and sequence

– Tighten bolts in stages in the sequence given:

stage	Bolts	Tightening torque
1st	-arrows-	Tighten to 11 Nm in diagonal sequence, working from centre outwards
2nd	-arrows-	Tighten to 22 Nm in diagonal sequence, working from centre outwards
3.	-arrows-	Tighten to 22 Nm in diagonal sequence, working from centre outwards <ul style="list-style-type: none"> <li>• This procedure has been specified in order to compensate for the settling of the components.</li> </ul>

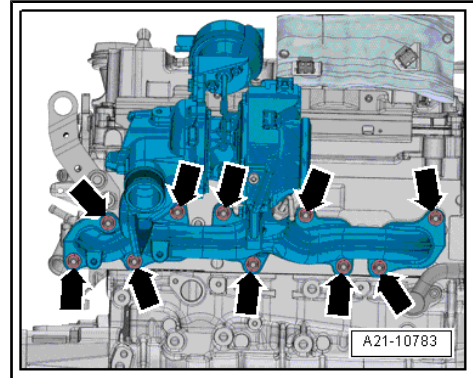

## 1.2 Turbo compressor: removing and fitting

⇒ [“1.2.1 Turbo compressor: removing and fitting”, page 254](#)

⇒ [“1.2.2 Removal and installation of the turbocharger, engine codes CRVA, CRVC, CRGA”, page 265](#)

### 1.2.1 Turbo compressor: removing and fitting



#### Caution

*If the turbocharger has suffered mechanical damage (e.g. damaged compressor wheel), it is not sufficient merely to fit a new turbocharger. The following work must be performed in order to avoid further damage:*

- ◆ *Check air cleaner housing, air filter element and air hoses for dirt and foreign particles.*
- ◆ *Check the whole charge air path and charge air cooler for foreign objects.*
- ◆ *If foreign objects are discovered in the charge air system, clean the charge air path and, if necessary, renew the charge air cooler.*

#### Special tools and workshop equipment required

- ◆ Hose clamps, up to 25 mm - 3094-

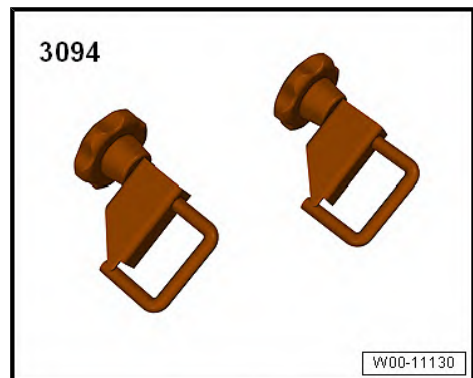

- ◆ Hose clip pliers - VAS 6362-

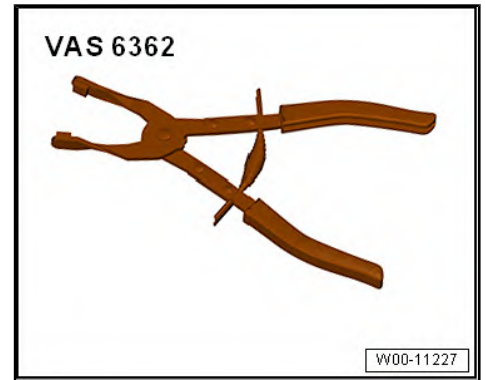

- ◆ Wrench XZN 10 - T10501-



- ◆ Tool set - T10395-

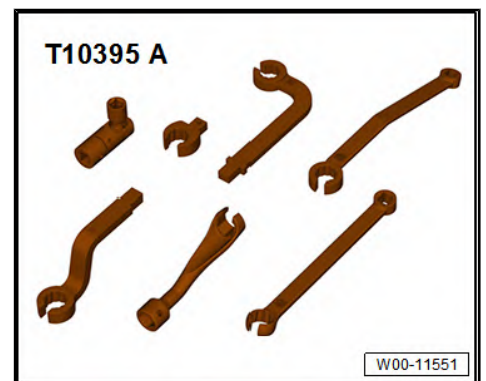

- ◆ Sealing cap set for engine - VAS 6122-

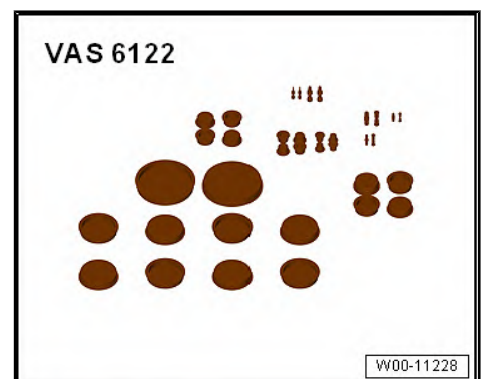

- ◆ Hooks - T40207-

## Removal



### Note

Re-attach all heat insulation sleeves at the same locations when re-installing.



### Caution

*Risk of malfunctions caused by dirt.*

- ◆ Take into account: ⇒ **"3.1 Cleaning rules", page 13** .

- Remove engine cover. ⇒ [page 56](#)
- Open cap -arrow- on coolant expansion tank.



### WARNING

*Hot coolant and vapours can cause burns!*

- ◆ When the engine is warm the cooling system is under pressure.
- ◆ To relieve the overpressure cover the cap of the coolant expansion tank with a cloth and carefully open it.

- For reasons of space, remove the air filter housing together with the intake hose ⇒ [page 321](#) .

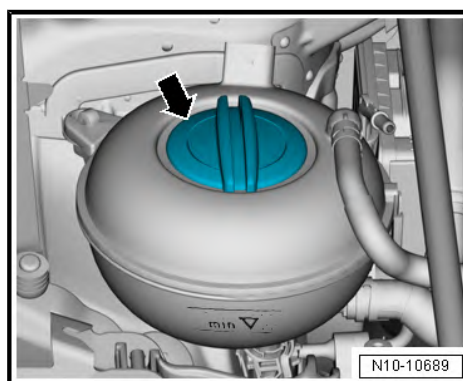

### LHD vehicles with exhaust gas pressure sensor 1 - G450- and pressure differential sender - G505- :

- Open heat insulation sleeve -1-.
- Take electrical connector -5- out of bracket, unplug it and move electrical wiring clear.
- Disconnect electrical connectors -3, 4 and 6- and move wiring harness clear.
- Remove bolts -2- , move support with differential pressure indicators back.

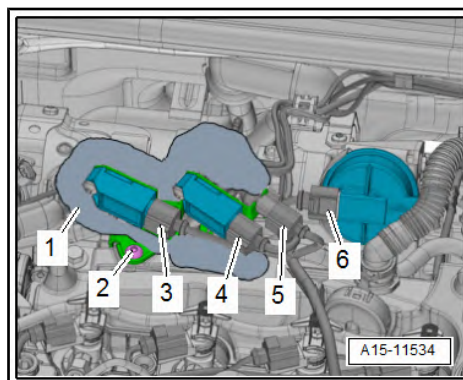

- Disconnect electrical connections, take cable out of the brackets and place over the engine.

- 1 - For exhaust gas temperature sender 4 - G648-
- 2 - For exhaust gas temperature sender 3 - G495-
- 3 - For exhaust gas temperature sender 2 - G448-
- 4 - For Lambda probe 1 before catalytic converter - GX10- .

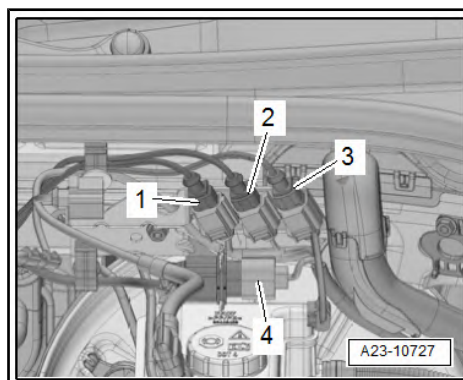

**LHD vehicles with pressure differential sender - G505- :**

- Open heat insulation sleeve -1-.
- Take electrical connector -4- out of bracket, unplug it and move electrical wiring clear.
- Unplug electrical connectors -3, 5- and move electrical wiring harness clear.
- Remove bolt -2- and move bracket with pressure differential sender - G505- towards rear.

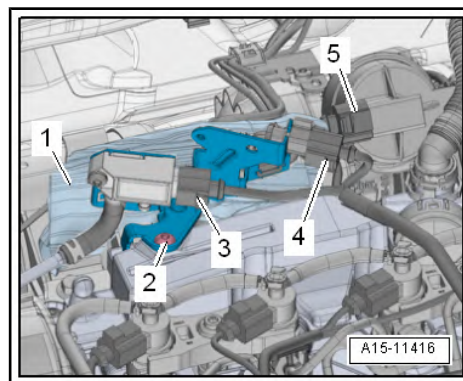

- Disconnect electrical connections, take cable out of the brackets and place over the engine:

- 2 - For exhaust gas temperature sender 4 - G648-
- 3 - For exhaust gas temperature sender 3 - G495-
- 4 - For Lambda probe 1 before catalytic converter - GX10- .

**All vehicles (continued):**

- Remove front exhaust pipe ⇒ [page 378](#) .
- If fitted, remove lambda probe 1 after catalytic converter - GX7- ⇒ [page 363](#) .
- If fitted, remove exhaust temperature sender 4 - G648- ⇒ [page 411](#) .
- Drain coolant ⇒ [page 181](#) .
- Remove the rear coolant pipe ⇒ [page 217](#) .
- Remove coolant pipes (left-side) ⇒ [page 215](#) .
- Remove bolt -arrow-, move pipe clear and push to side.

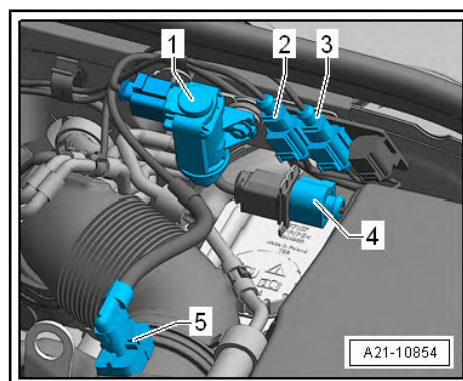

 **Note**

*Disregard items marked -A and B-.*

- Fit assembly tool - T10511- as shown.
- Attach retaining bracket -arrow- in lifting shackle of emission control module.

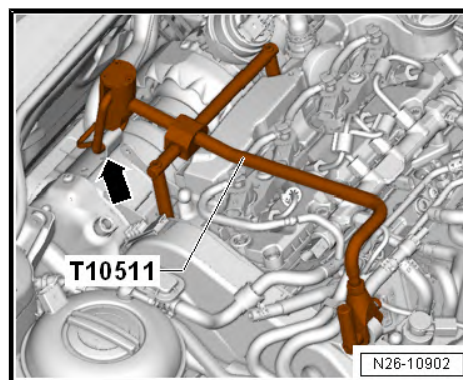
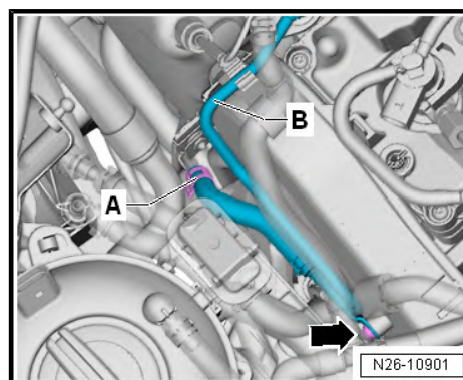

- Remove bolt -arrows-.

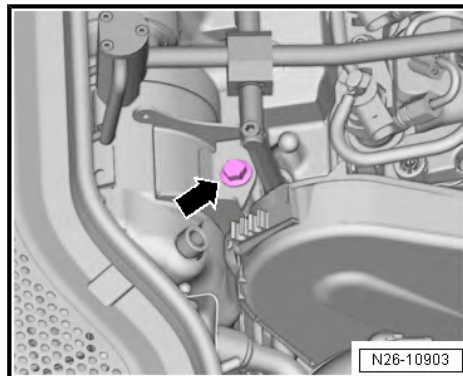

- Press the release buttons on the crankcase breather hose -1- and remove it from the cylinder head cover.
- Unscrew bolt -3-, swing air pipe with inlet connection -2- to rear and pull off from turbocharger.

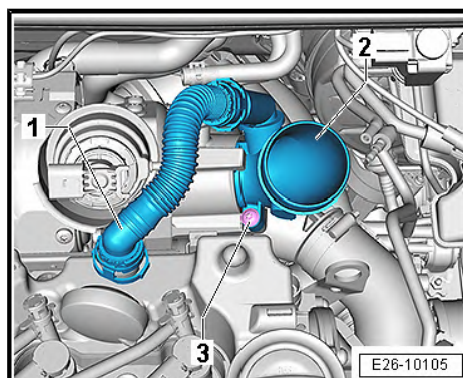

- Detach vacuum hose -2- from vacuum unit of turbocharger.
- Disconnect vacuum hose -1- from T-piece.
- Release catch -arrow- and disconnect vacuum hose -1-.

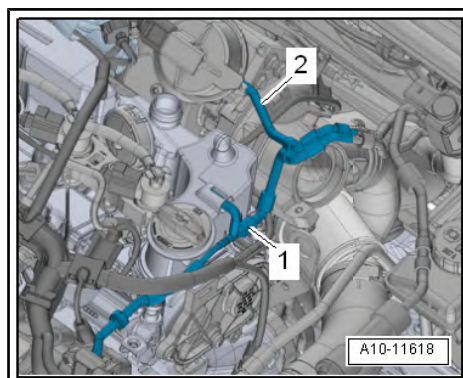

- Pull off vacuum hose -2-.



**Note**

*Disregard -item 1, 3-.*

- Push vacuum hoses to the side.

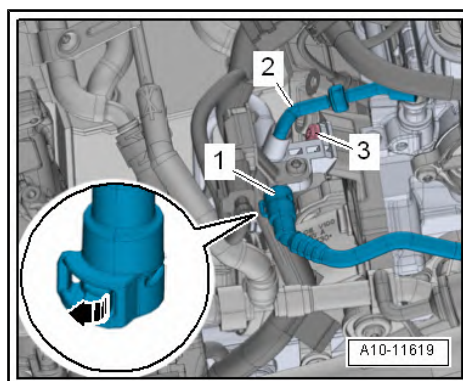

- Unscrew bolts -arrows- and remove resonator -1-.

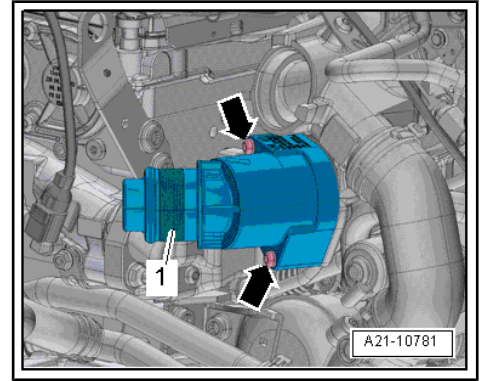

#### Vehicles with water pipe above emission control module:

- Clamp coolant hose -1- with a hose clamp for hoses up to 25 mm - 3094- .
- Loosen the hose clip -1-, remove the coolant hose.
- Remove bolts -2 and 3- and pivot coolant pipe clear to one side.

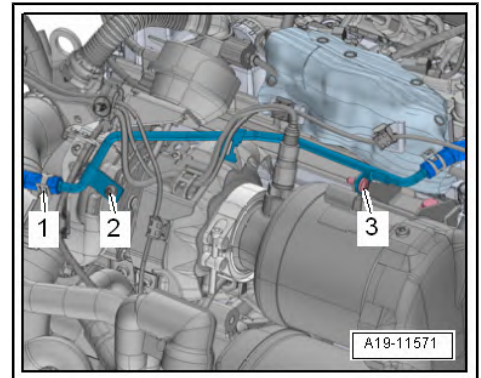

#### Vehicles with water pipe above turbocharger:

- Remove coolant pipe -1- on turbocharger and on engine.
- To do this, break the electrical plug connection -4- and free the electrical connecting lead from the fastenings.
- Bend up the clamp -arrow- and take the coolant hose out of the coolant pipe -1-.
- Unscrew the bolts -2- and take out the pipe.

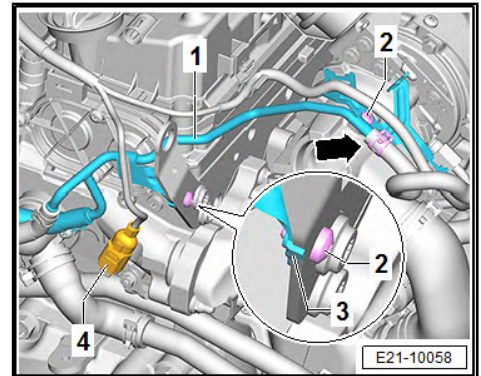

#### Vehicles with RHD

- Remove emission control module ⇒ [page 390](#) .

#### Vehicles with four-wheel drive

- Remove exhaust gas recirculation cooler ⇒ [page 431](#) .

#### Front-wheel drive vehicles

- Loosen the hose clip -3-, remove the air intake hose.
- Remove bolt -1- with the wrench XZN 10 - T10501- .
- Push heat insulation sleeve to one side and unplug electrical connector -5-.
- Loosen the hose clip -7-, remove the coolant hose.
- Loosen bolt -6- and push screw-type clip towards particulate filter.

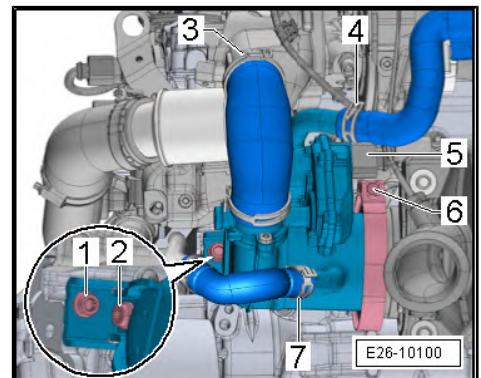

 **Note**

Ignore -items 2 and 4-.



**Note**

Use the hook to disconnect the -plug - connection 5 - T40207- .  
Release the plug lock -1- -in the direction of the arrow-.

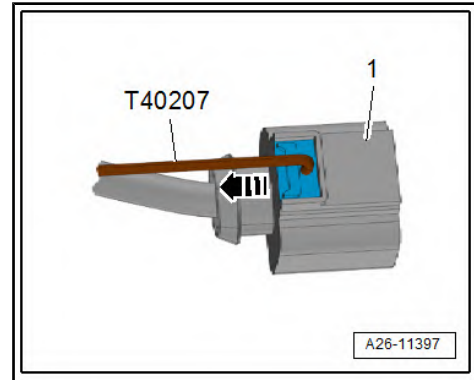

- Loosen bolt -1- and remove screw-type clip.
- Remove screws -4-.
- Remove bolts -5, 6- using the XZN 10 - T10501- .
- Pull down mechanism -2- of assembly tool - T10511- in -direction of arrow - to release the retaining bracket of the transportation shackle of the emission control module.

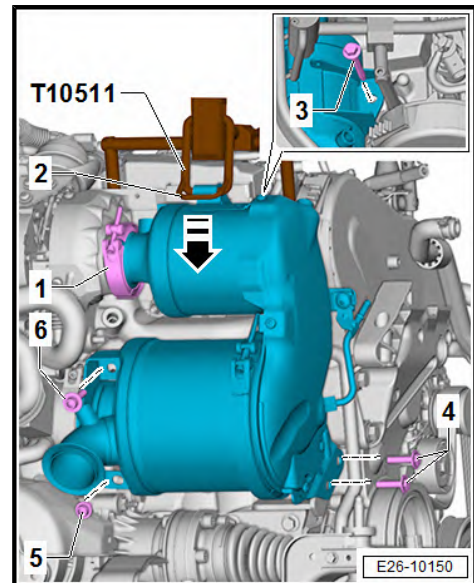

- Press back exhaust gas circulation cooler -1-, separate from emission control module -2- in -direction of arrow- and set both of them aside so that there is no risk of damage.

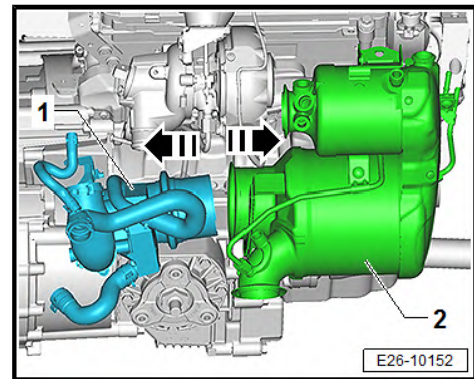

**All vehicles (continued):**

- Remove the bolts -1 and 2- and the lock nut -4- .
- Unscrew bolts -3 and 5- and detach oil return line.

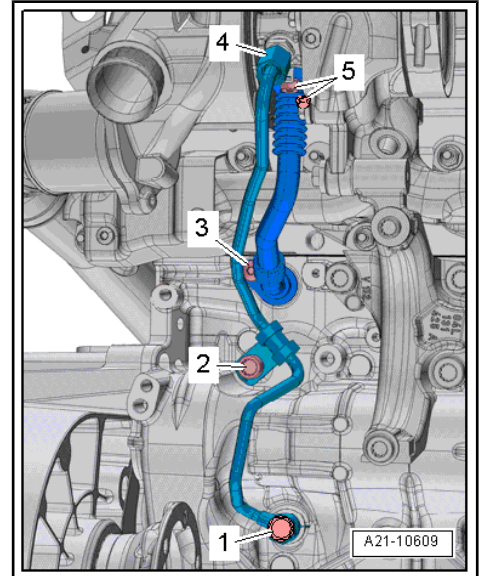

- Unscrew bolts -1, 3- ; remove the bracket -2- for the exhaust cleaning module.

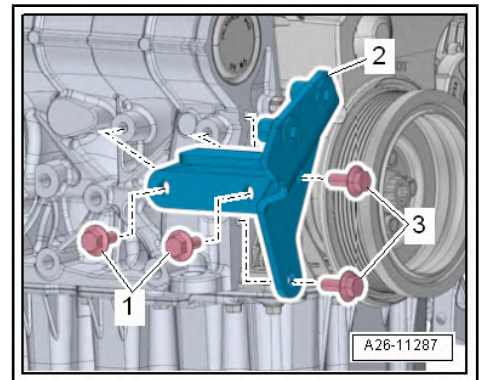

- Unscrew bolts -1 and 4- and extract the exhaust gas turbo-charger.

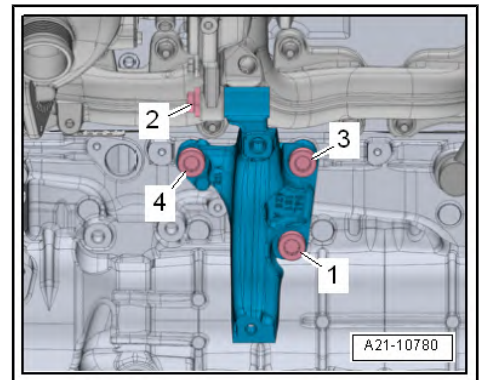

- Remove assembly tool - T10511- .

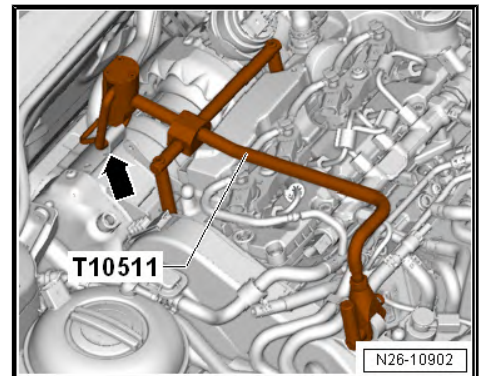

- Remove bolts -arrows- and detach heat shield -1-.

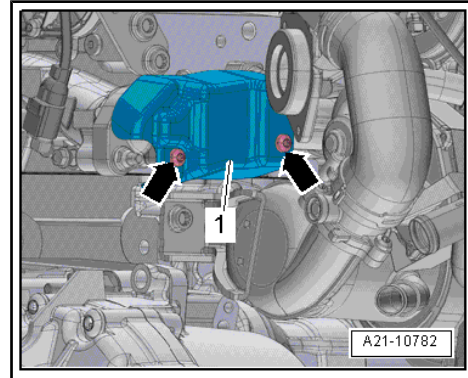

- Unscrew nuts -arrows-, pull turbocharger with exhaust manifold off cylinder head and remove it upwards.

### Installation

Installation is carried out in the reverse order; note the following:



#### Note

- ◆ Replace gaskets, seals, O-rings and self-locking nuts after removal.
- ◆ Fill turbocharger with engine oil at connection for oil supply line.
- ◆ Hose unions and air intake pipes/hoses must be free of oil and grease when installing.
- ◆ Secure all hose connections with the correct type of hose clips (same as original equipment) ⇒ Electronic parts catalogue .
- ◆ After installing the turbocharger, allow the engine to idle for approx. 1 minute without pressing the accelerator to ensure that the turbocharger is supplied with oil.

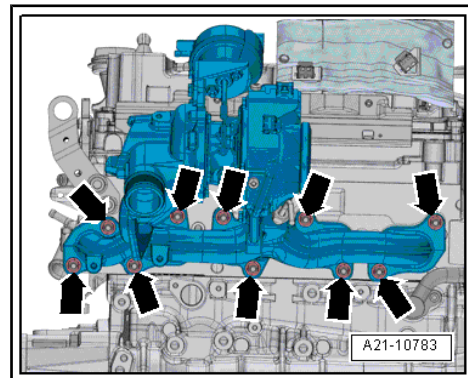

### Vehicles with water pipe above turbocharger:

- When installing coolant pipe -1-, make sure that guide -3- is properly seated in bracket.

### All vehicles (continued):

- Observe electrical connections and routing ⇒ Electrical system; Rep. gr. 97 ; Relay carriers, fuse carriers, electronics boxes; Overview of fitting locations - relay carriers, fuse carriers, electronics boxes and ⇒ Current flow diagrams, Electrical fault finding and Fitting locations.

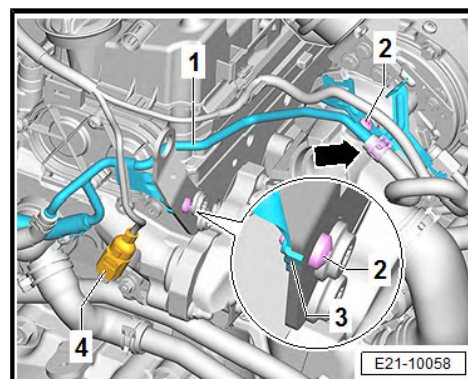

- Fit assembly tool - T10511- as shown.
- Attach retaining bracket -arrow- in lifting shackle of emission control module.

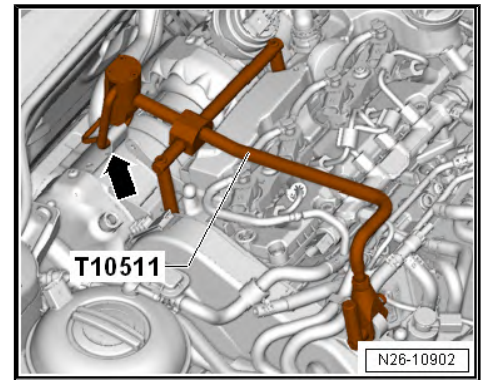

### Turbocharger - tightening torque and sequence

- Tighten bolts in stages in the sequence given:

stage	Bolts	Tightening torque
1st	-arrows-	Tighten to 11 Nm in diagonal sequence, working from centre outwards
2nd	-arrows-	Tighten to 22 Nm in diagonal sequence, working from centre outwards
3.	-arrows-	Tighten to 22 Nm in diagonal sequence, working from centre outwards <ul style="list-style-type: none"> <li>• This procedure has been specified in order to compensate for the settling of the components.</li> </ul>

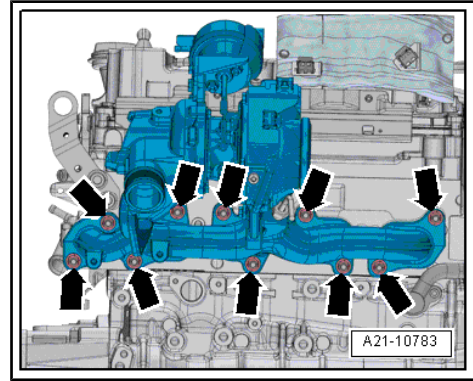

- Install the oil return and provision line ⇒ [page 252](#) .
- Electrical connections and routing ⇒ Electrical system; Rep. gr. 97 ; Relay carriers, fuse carriers, electronics boxes; Overview of fitting locations - relay carriers, fuse carriers, electronics boxes and ⇒ Current flow diagrams, Electrical fault finding and Fitting locations.
- Install the central bracket for the exhaust cleaning module ⇒ [page 253](#)
- Install the bracket for the exhaust cleaning module ⇒ [page 387](#)
- Install emission control module ⇒ [page 390](#) .
- Install exhaust gas recirculation cooler ⇒ [page 431](#) .
- Install the coolant pipe (rear) ⇒ [page 217](#) .
- Screw the propshaft to the angle gear ⇒ Rep. gr. 39 ; Propshaft; assembly overview - Propshaft
- Install the exhaust pipe ⇒ [page 378](#) .
- Attach and adjust the gate selector cable ⇒ Rep. gr. 34 ; Selector mechanism; Assembly overview - Selector mechanism .
- Connect vacuum hose ⇒ [page 295](#) .
- Install engine cover panel ⇒ [page 56](#) .



#### Note

- ◆ *After new components have been installed (engine/short engine, cylinder head, camshaft housing or turbocharger) the oil pressure control must be set to max. pressure for approx. 1,000 km. This will compensate for the increased friction during run-in of new components, and a better transport of wear-related particles is guaranteed. To do this, connect vehicle diagnostic and service information system , switch on ignition and select the following menu item:*
- ◆ Oil pressure for entry in the engine

 Note

*Depending on the vehicle, the engine and the firmware version of the vehicle diagnostic and service information system, the specified path may vary slightly.*

### Specified torques

- ◆ ⇒ [“1.1 Exploded view - turbocharger”, page 252](#)
- ◆ Exhaust gas recirculation cooler - tightening torque and sequence ⇒ [page 422](#)
- ◆ Emission control module bracket - Tightening torques and sequence ⇒ [page 253](#)
- ◆ ⇒ [“2.1 Assembly overview - emission control”, page 385](#)
- ◆ ⇒ [“3.1 Assembly overview - exhaust gas temperature regulation”, page 411](#)
- ◆ ⇒ [“1.1 Exploded view - silencers”, page 366](#)
- ◆ ⇒ [“3.1 Exploded view - coolant pipes”, page 208](#)
- ◆ ⇒ [“2.1 Exploded view - toothed belt cover”, page 114](#)
- ◆ ⇒ [“4.1 Exploded view - air cleaner housing”, page 319](#)
- ◆ ⇒ [“5.1 Exploded view - intake manifold”, page 323](#)

## 1.2.2 Removal and installation of the turbocharger, engine codes CRVA, CRVC, CRGA



### Caution

*If the turbocharger has suffered mechanical damage (e.g. damaged compressor wheel), it is not sufficient merely to fit a new turbocharger. The following work must be performed in order to avoid further damage:*

- ◆ *Check air cleaner housing, air filter element and air hoses for dirt and foreign particles.*
- ◆ *Check the whole charge air path and charge air cooler for foreign objects.*
- ◆ *If foreign objects are discovered in the charge air system, clean the charge air path and, if necessary, renew the charge air cooler.*

Special tools and workshop equipment required

- ◆ Hose clip pliers - VAS 6362-

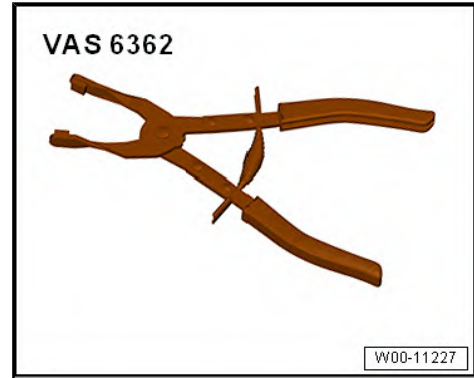

- ◆ Socket insert XZN 10 - T10501-



## Removal



### Note

Re-attach all heat insulation sleeves at the same locations when re-installing.



### Caution

*Risk of malfunctions caused by dirt.*

- ◆ Take into account: ⇒ ***"3.1 Cleaning rules", page 13***

- Remove engine cover. ⇒ [page 56](#)
- Drain coolant ⇒ [page 181](#) .
- Remove catalytic converter ⇒ [page 388](#) .
- Remove the rear coolant pipe ⇒ [page 217](#) .
- Press the release buttons on the crankcase breather hose -1- and remove it from the cylinder head cover.
- Lay bare the vacuum hoses at the air pipe -arrows-.
- Unscrew bolt -2-, swing air pipe with inlet connection to rear and pull off from turbocharger.

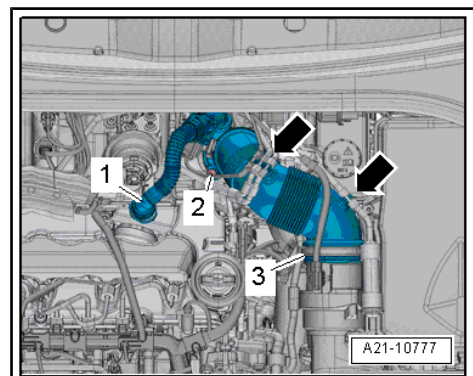

- Unscrew bolts -arrows- and remove resonator -1-.
- Disconnect electrical plug-in connector of the exhaust gas temperature sender 1 - G235- .
- Remove catalytic converter ⇒ [page 388](#) .
- Remove exhaust gas recirculation cooler ⇒ [page 425](#) .

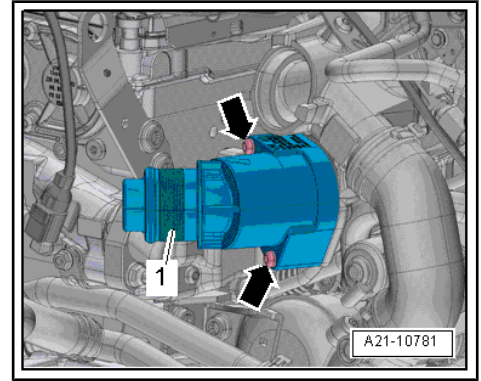

- Unscrew bolts -1 ... 5- and remove bracket for cooler for exhaust gas recirculation.

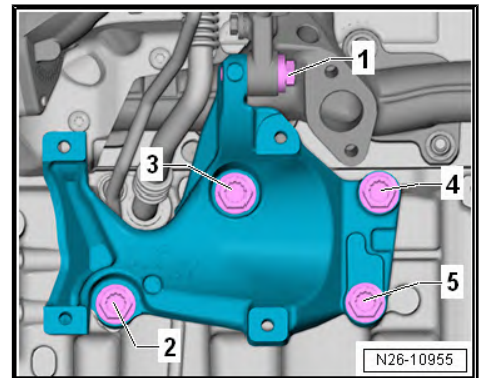

- Unscrew bolt -2- and union nut -4-.
- Unscrew bolts -3 and 5- and detach oil return line.

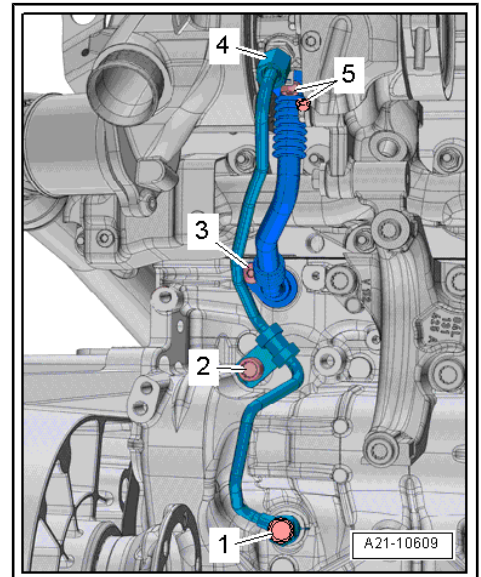

- Remove bolts -arrows- and detach heat shield -1-.

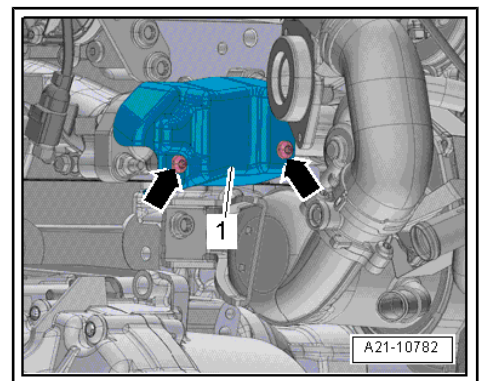

- Detach vacuum hose -2- from vacuum unit of turbocharger.

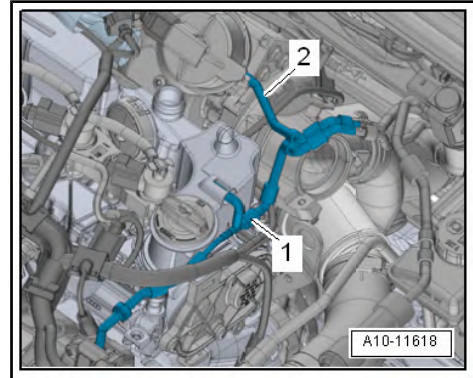

- Unscrew nuts -arrows-, pull turbocharger with exhaust manifold off cylinder head and remove it upwards.

### Installation

Installation is carried out in the reverse order; note the following:

#### Note

- ◆ *Replace gaskets, seals, O-rings and self-locking nuts after removal.*
  - ◆ *Fill turbocharger with engine oil at connection for oil supply line.*
  - ◆ *Hose unions and air intake pipes/hoses must be free of oil and grease when installing.*
  - ◆ *Secure all hose connections with the correct type of hose clips (same as original equipment) ⇒ Electronic parts catalogue .*
  - ◆ *After installing the turbocharger, allow the engine to idle for approx. 1 minute without pressing the accelerator to ensure that the turbocharger is supplied with oil.*
- Electrical connections and routing ⇒ Electrical system; Rep. gr. 97 ; Relay carriers, fuse carriers, electronics boxes; Overview of fitting locations - relay carriers, fuse carriers, electronics boxes and ⇒ Current flow diagrams, Electrical fault finding and Fitting locations.
  - Remove the rear coolant pipe ⇒ [page 217](#) .
  - Install bracket for exhaust gas recirculation cooler ⇒ [page 424](#)
  - Install exhaust gas recirculation cooler ⇒ [page 425](#) .
  - Install catalytic converter ⇒ [page 388](#) .
  - Install front exhaust pipe ⇒ [page 378](#) .
  - Connect vacuum hose ⇒ [page 295](#) .
  - Install engine cover panel ⇒ [page 56](#) .

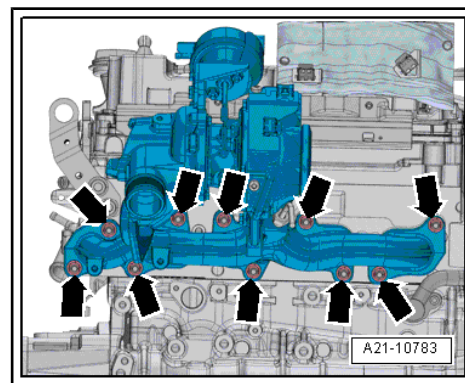

#### Note

- ◆ *After new components have been installed (engine/short engine, cylinder head, camshaft housing or turbocharger) the oil pressure control must be set to max. pressure for approx. 1,000 km. This will compensate for the increased friction during run-in of new components, and a better transport of wear-related particles is guaranteed. To do this, connect vehicle diagnostic and service information system , switch on ignition and select the following menu item:*
- ◆ Oil pressure for entry in the engine

#### Note

*Depending on the vehicle, the engine and the firmware version of the vehicle diagnostic and service information system , the specified path may vary slightly.*

### Specified torques

- ◆ ⇒ [“1.1 Exploded view - turbocharger”, page 252](#)

◆ ⇒ ["2.1 Assembly overview - emission control", page 385](#)

### 1.3 Renewing vacuum unit for turbocharger

#### Special tools and workshop equipment required

◆ Hand vacuum pump - VAS 6213-

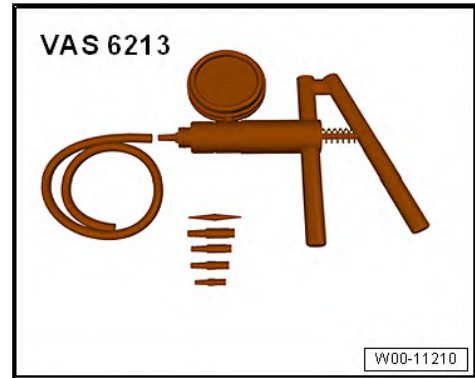

◆ Vehicle diagnosis tester

#### Removal

- Remove engine cover. ⇒ [page 56](#)

#### Variant 1:

- Disconnect electrical connector -3- at position sender for charge pressure positioner - G581- .
- Detach vacuum hose -2- from vacuum unit of turbocharger.

#### Note

*When removing and installing the circlip, do not apply too much force on the lever linkage. The turbocharger may be damaged when the circlip is pushed down, e.g using a large screwdriver.*

- Remove circlip -4-.
- Remove bolts -1- for vacuum unit.
- Disengage control rod at adjusting lever and detach vacuum unit with position sender for charge pressure positioner - G581- .

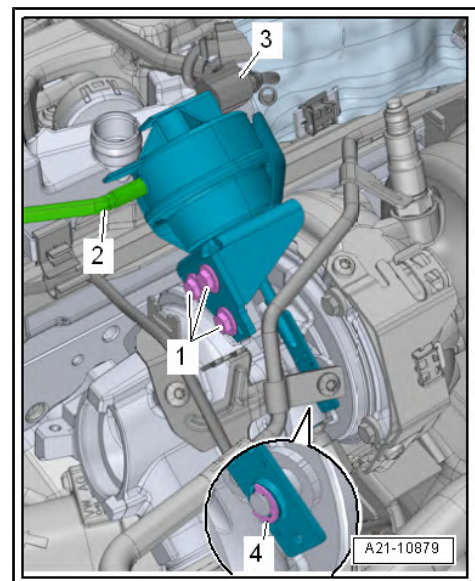

### Variant 2:

- Disconnect electrical connector -2- at position sender for charge pressure positioner - G581- .
- Detach vacuum hose -1- from vacuum unit of turbocharger.

#### Note

*When removing and installing the circlip, do not apply too much force on the lever linkage. The turbocharger may be damaged when the circlip is pushed down, e.g using a large screwdriver.*

- Remove circlip -4-.
- Remove bolts -3- for vacuum unit.
- Disengage control rod at adjusting lever and detach vacuum unit with position sender for charge pressure positioner - G581- .

### Installation

#### Note

*Use new bolts and a new circlip from the repair kit.*

### Variant 1:

- Attach control rod to adjusting lever.
- Fit vacuum unit, and screw in bolts -1- to stop by hand.

#### Note

*When removing and installing the circlip, do not apply too much force on the lever linkage. The turbocharger may be damaged when the circlip is pushed down, e.g using a large screwdriver.*

- Install circlip -4-.
- Disconnect electrical connector -3- at position sender for charge pressure positioner - G581- .

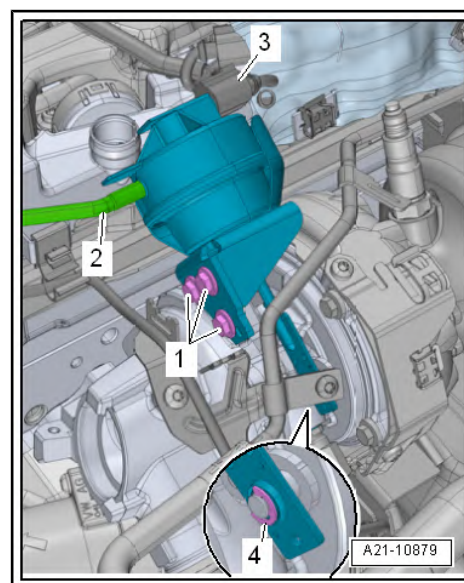
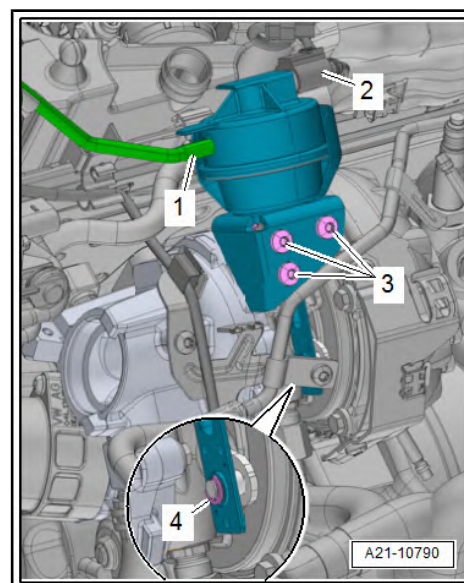

**Variant 2:**

- Attach control rod to adjusting lever.
- Fit vacuum unit, and screw in bolts -3- to stop by hand.



**Note**

*When removing and installing the circlip, do not apply too much force on the lever linkage. The turbocharger may be damaged when the circlip is pushed down, e.g using a large screwdriver.*

- Install circlip -4-.
- Disconnect electrical connector -2- at position sender for charge pressure positioner - G581- .

**Continued for all versions:**

- Seal bolts with sealing paint from repair kit.
- Install engine cover panel ⇒ [page 56](#) .
- Connect vehicle diagnostic tester .
- Turn off the engine and erase event memory ⇒ Vehicle diagnostic tester.
- Carry out basic setting of vacuum unit. For this purpose, use Vehicle diagnostic and service information system .

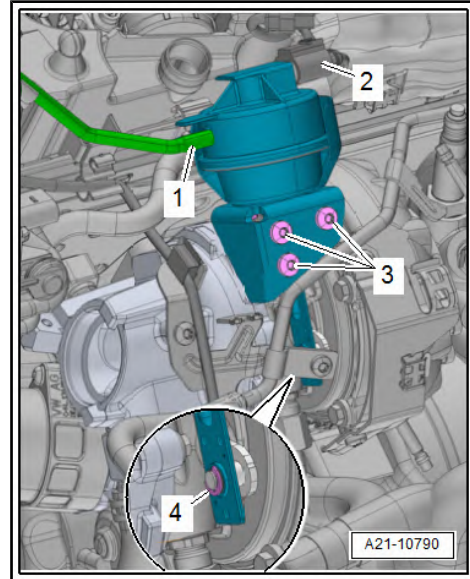

**Tightening torque**

Bolts	Tightening torque
Bolts -1, 3-	10 Nm

**Adjust control rod for vacuum unit:**

- To do this, measure the raw voltage.
- Use ⇒ Vehicle diagnostic tester.
- Read voltage value in self-diagnosis.
- Move slide ring -1- on hand vacuum pump - VAS 6213- to position -A- for "vacuum".

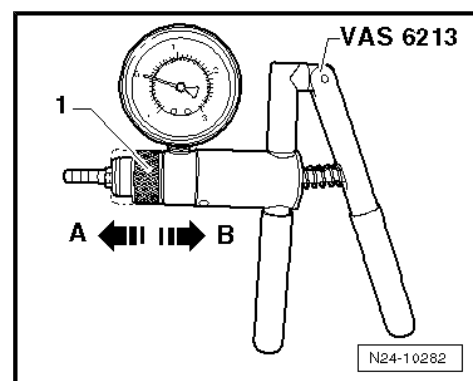

- Connect hand vacuum pump - VAS 6213- to vacuum unit -arrow-.



**Caution**

*Risk of damage to vacuum unit on account of excessive vacuum.*

- ◆ *The negative pressure must never exceed -800 mbar.*

**Adjusting voltage value**

- Operate hand vacuum pump - VAS 6213- until a vacuum between -650 ... -700 mbar is displayed on pressure gauge.

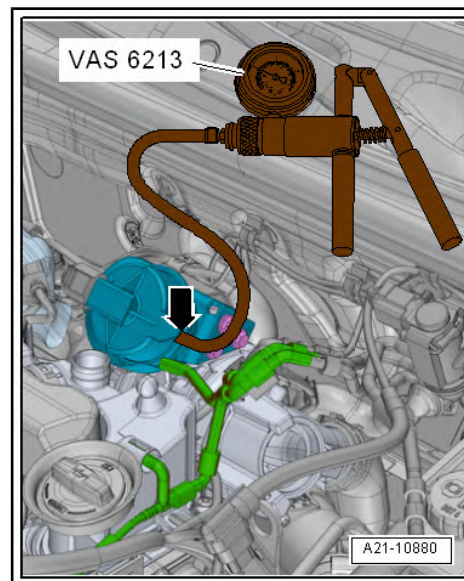

**Variant 1:**

- Move vacuum unit in -direction of arrow-, until a voltage value of  $0.75 \pm 0.02$  Volt is indicated on the  $\Rightarrow$  Vehicle diagnostic tester.
- Tighten the bolts -1- to 10 Nm.

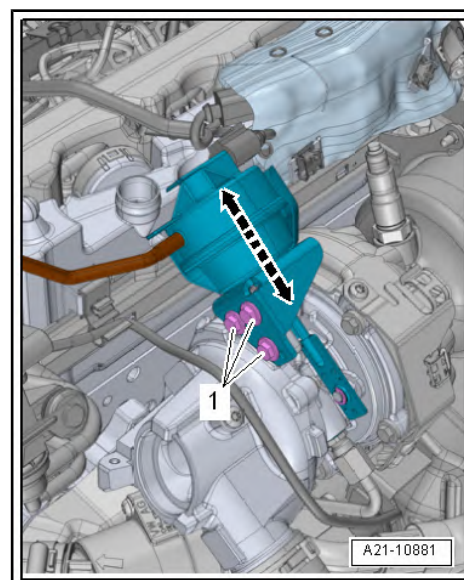

**Variant 2:**

- Move vacuum unit in -direction of arrow-, until a voltage value of  $0.75 \pm 0.02$  Volt is indicated on the  $\Rightarrow$  Vehicle diagnostic tester.
- Tighten the bolts -1- to 10 Nm.

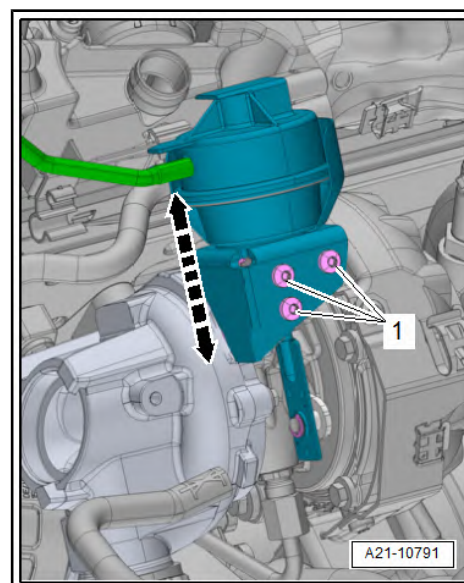

- Move adjuster ring -1- on hand vacuum pump - VAS 6213- to position -B- to vent vacuum in vacuum unit to ambient pressure.

#### Checking voltage value

- Move slide ring -1- on hand vacuum pump - VAS 6213- to position -A- for "vacuum".
- Operate hand vacuum pump - VAS 6213- until a vacuum between -650 ... -700 mbar is displayed on pressure gauge.
- A voltage value of  $0.75 \pm 0.02$  Volt must be indicated on the ⇒ Vehicle diagnostic tester.

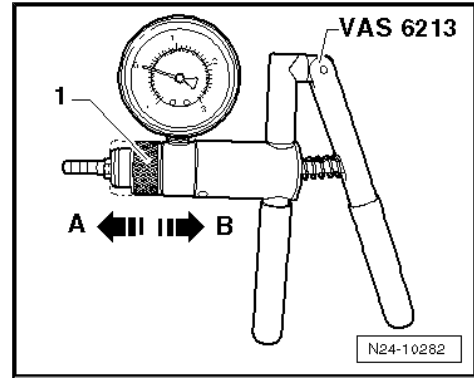

#### Voltage value is not correct



#### Note

The illustration shows the version 1.

- Loosen bolt -1-
- Adjust voltage value ⇒ [page 273](#) .

#### Voltage value in good condition

- Seal bolts with sealing paint from repair kit.
- Install engine cover panel ⇒ [page 56](#) .
- Turn off the engine and erase event memory ⇒ Vehicle diagnostic tester.

#### Tightening torque

Bolts	Tightening torque
Bolts -1-	10 Nm

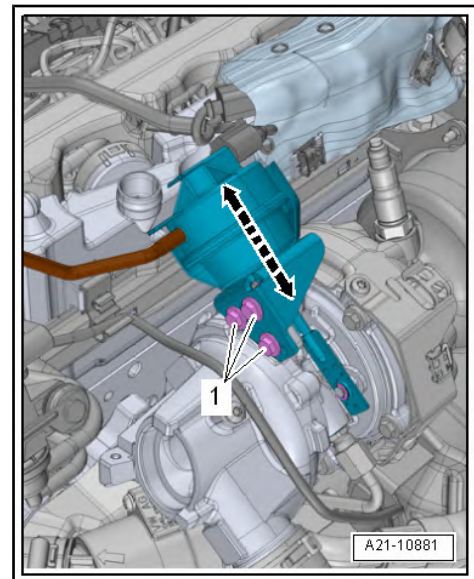

## 1.4 Removing and installing connection for turbocharger

Hose clip pliers - VAS 6362-



- If present: pull off vacuum hose -arrow-.



**Caution**

*Depending on the vehicle version and country-specific modifications, crankcase breather hoses which cannot be removed from the cylinder head cover without being damaged may be installed. This type of crankcase breather hose must only be disconnected at the connecting piece for the air hose.*

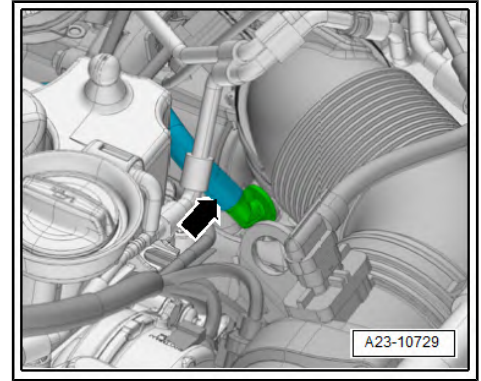

- Remove hose -4- for crankcase breather system from air hose.
- To do this, press release mechanism.
- Lay bare the vacuum hoses at the air pipe -arrows-.
- Loosen the hose clip -2-, remove the air intake pipe from the mass air flow sensor - G70- .
- Unscrew the bolt -5-.
- Turn air pipe with connecting piece towards rear.
- Turn it towards rear until guides on connecting piece are detached from locking mechanism.
- Pull air pipe with connecting piece of turbocharger.

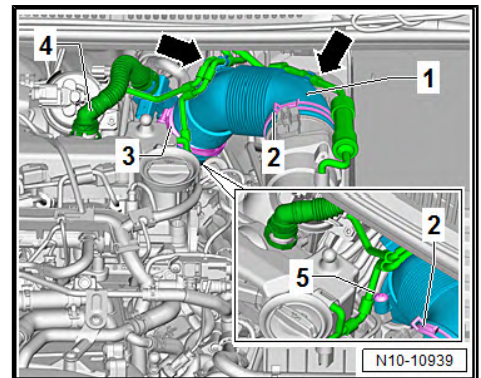

**Installation**

Installation is carried out in the reverse order; note the following:

- Loosen screw-type clip between connection and air intake hose -3-.
- Pull off air intake hose.
- Fit connecting piece in such a way that the guides are positioned in front of the locking mechanism.
- Push in connecting piece, and turn it towards front to stop.
- Connect air intake hose to connection.
- Tighten screw-type clip -3-.

Further assembly in reverse order of removal.

**Tightening torque:**

- ◆ ⇒ ["1.1 Exploded view - turbocharger", page 252](#)

## 2 Supercharger air system:

⇒ ["2.1 Assembly overview - charge air system", page 276](#)

⇒ ["2.2 Removing and installing charge pressure sender G31", page 278](#)

⇒ ["2.3 Checking charge air system for leaks", page 278](#)

⇒ ["2.4 Checking charge air cooler for leaks", page 280](#)

### 2.1 Assembly overview - charge air system

#### 1 - Oil seal

- Renew following removal

#### 2 - Dowel pin

#### 3 - Bolt.

- 8 Nm

#### 4 - Seal

- Renew following removal

#### 5 - Bolt.

- Tightening torque and sequence ⇒ [page 323](#) .

#### 6 - Bracket/bearing/support

- For intake manifold

#### 7 - Bolt.

- Tightening torque and sequence ⇒ [page 323](#) .

#### 8 - Bolt.

- Renew following removal
- Tightening torque and sequence ⇒ [page 323](#) .

#### 9 - Dowel pin

#### 10 - Bolt.

- 8 Nm

#### 11 - Intake manifold with charge air cooler

- Intake manifold and charge air cooler are combined as one unit

- Removing and fitting ⇒ [page 325](#)

#### 12 - Bolt.

- Renew following removal
- Tightening torque and sequence ⇒ [page 323](#) .

#### 13 - Charge air temperature sender after charge air cooler - G811-

- Removing and fitting ⇒ [page 347](#)
- 22 Nm

#### 14 - Seal

- Renew following removal

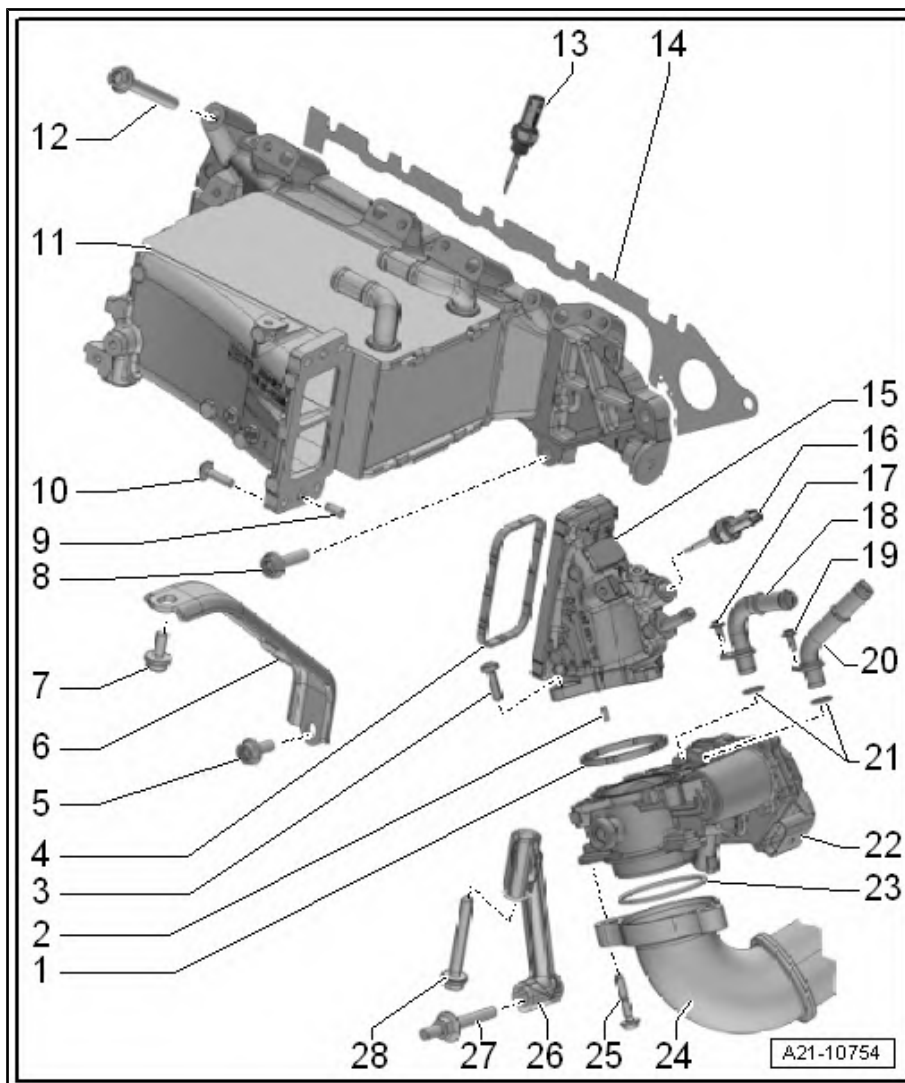

### 15 - Connection

- for throttle valve control unit - J338-

### 16 - Intake air temperature sensor - G42-

- Removing and fitting ⇒ [page 347](#)
- 22 Nm

### 17 - Bolt.

- 10 Nm

### 18 - Coolant pipe

### 19 - Bolt.

- 10 Nm

### 20 - Coolant pipe

### 21 - O-rings

- Renew following removal

### 22 - Throttle valve control mechanism - J338-

- With throttle valve potentiometer - G69-
- Removing and fitting ⇒ [page 323](#)

### 23 - O-ring

- Renew following removal

### 24 - Air intake pipe

### 25 - Bolt.

- Tightening torque and sequence ⇒ [page 323](#) .

### 26 - Bracket/bearing/support

- for throttle valve control unit - J338-

### 27 - Bolt.

- Tightening torque and sequence ⇒ [page 323](#) .

### 28 - Bolt.

- Tightening torque and sequence ⇒ [page 323](#) .

### Charge pressure sender - G31- - tightening torque

- Tighten bolt -2- to a torque of 9 Nm.

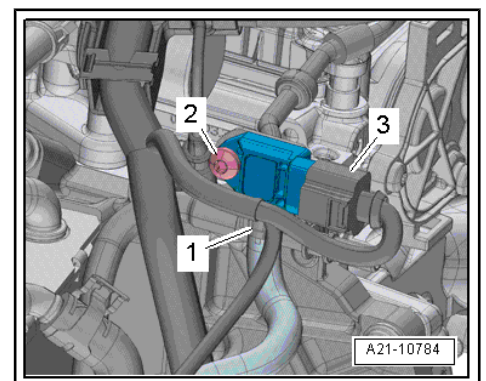

## 2.2 Removing and installing charge pressure sender - G31-

### Removal

- Remove engine cover. ⇒ [page 56](#)
- Unplug the electrical connector -3-.
- Before disconnecting hose from charge pressure sender - G31- , spray hose with suitable release agent.



### Caution

*Irreparable damage to charge pressure sender can be caused if the connection breaks off.*

- ◆ *Carefully disconnect hose from connection, taking care to keep hose straight.*

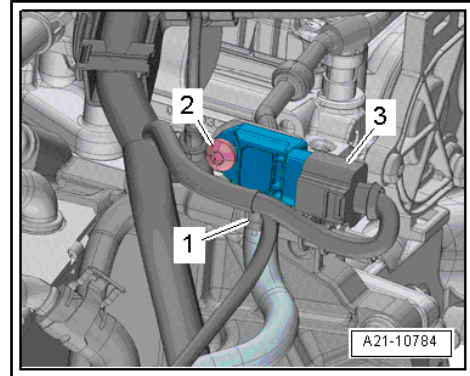

- Unscrew bolts -2- and remove charge pressure sender - G31- .

### Installation

Installation is carried out in the reverse order; note the following:

- Tightening torque  
⇒ [Fig. "“ Charge pressure sender -G31- - tightening torque”"](#), [page 277](#)
- Install engine cover panel ⇒ [page 56](#) .

## 2.3 Checking charge air system for leaks

### Special tools and workshop equipment required

- ◆ Charge air system tester - V.A.G 1687- with adapter - V.A.G 1687/12-

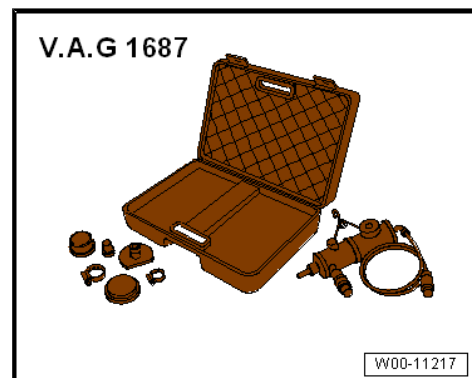

- ◆ Hose clip pliers - VAS 6362-



◆ Sealing cap set for engine - VAS 6122-

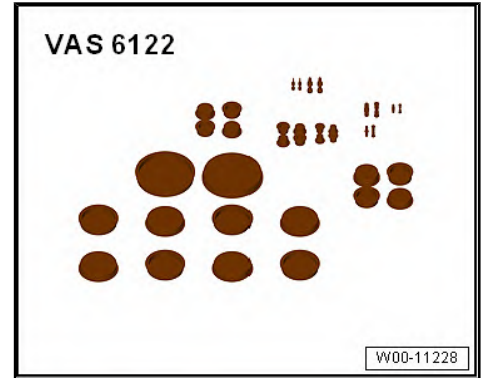

**Operation process**

- Remove engine cover. ⇒ [page 56](#)
- Free vacuum hoses -arrows-.
- Loosen hose clips -1, 2- and remove air pipe.

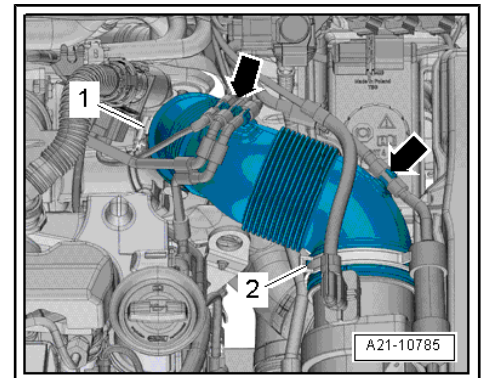

- Pull off crankcase breather pipe -arrow-.
- Seal connection with a bung -1- from engine bung set . Secure bung with a clip -2-.

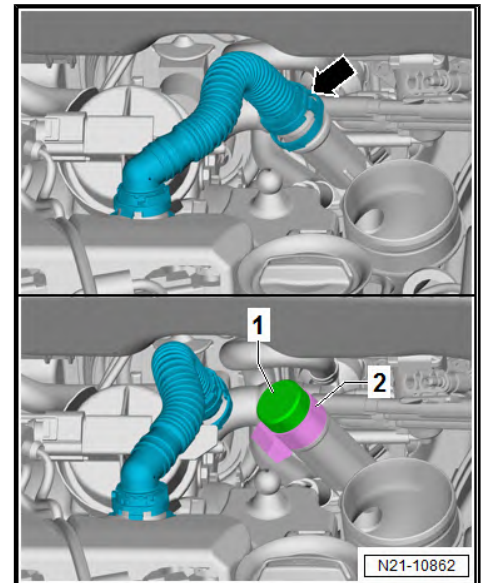

- Connect the adapter - V.A.G 1687/11- with -V.A.G 1687/15- to the exhaust gas turbocharger.
- Connect charge air system tester - V.A.G 1687- to adapter.

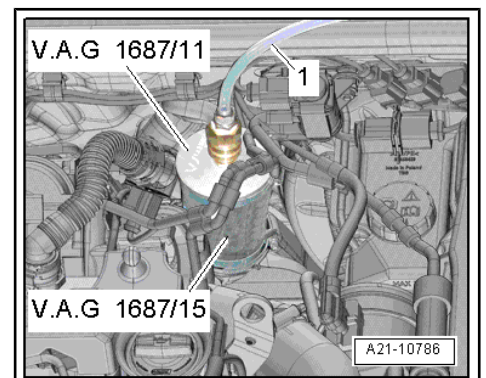

### Prepare charge air system tester - V.A.G 1687- as follows:

- Pull pressure control valve -2- upwards, unscrew it completely, and close valves -3- and -4-.
- Using a commercially available connection piece, connect charge air system tester - V.A.G 1687- to compressed air -1-.



#### Note

*If there is water in the inspection glass, -6- drain it via the drain plug.*

- Open valve -3-.
- Adjust pressure to 0.5 bar with pressure regulating valve -2-.
- Open valve -4- and wait until test circuit is full. If necessary readjust pressure to 0.5 bar.
- Check charge air system for leaks.
  - ◆ By listening
  - ◆ With your finger
  - ◆ Using commercially available leak detector spray
  - ◆ Using ultrasonic tester - V.A.G 1842 S-



#### Note

- ◆ *A small amount of air escapes through the valves and enters the engine and the exhaust gas recirculation cooler. Therefore a holding pressure test is not possible.*
- ◆ *How to use the ultrasonic tester - V.A.G 1842 S- ⇒ operating instructions .*
- ◆ *Release pressure in test circuit by detaching hose coupling from adapter before removing adapter.*

### Assembling

Assemble in reverse order.

### Specified torques

- ◆ ⇒ ["4.1 Exploded view - air cleaner housing", page 319](#)

## 2.4 Checking charge air cooler for leaks



#### Note

*A pressure of 0.5 bar is applied to the air side of the charge air cooler. While doing this, the pressure in the cooling system is measured.*

### Special tools and workshop equipment required

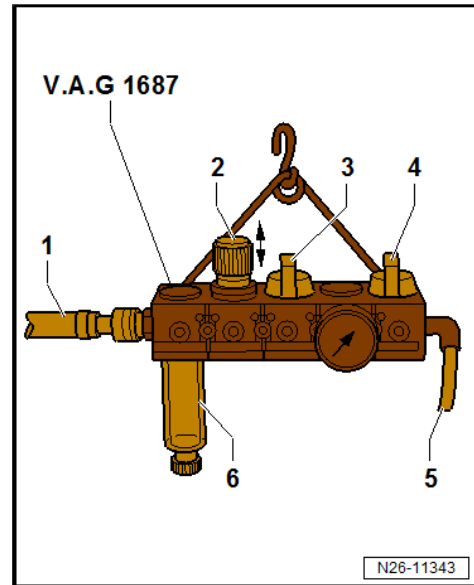

- ◆ Charge air system tester - V.A.G 1687-



- ◆ Y-branch - VAS 691 005/1-

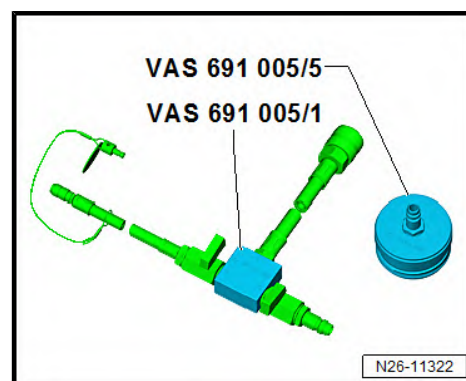

- ◆ Adapter for the testing functions - VAS 691 005/5-
- ◆ Turbocharger tester - V.A.G 1397A-

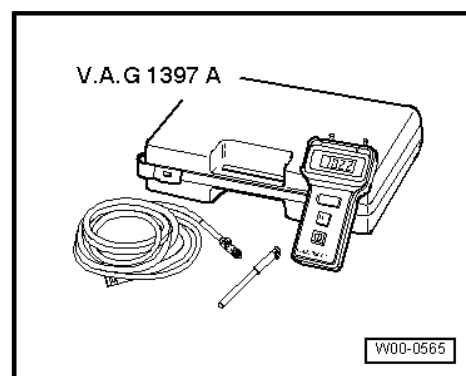

- ◆ Sealing cap set for engine - VAS 6122-

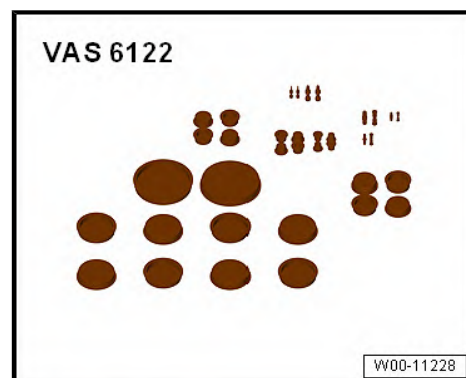

#### Test prerequisite

- Coolant temperature at least 40 °C.

### Connecting turbocharger tester - V.A.G 1397A- :

- Screw adapter - VAS 691 005/5- onto coolant expansion tank.
- Fit Y-branch - VAS 691 005/1- onto adapter - VAS 691 005/5- .
- Close valve -1- for connection »C«, and open valve -2- for connection »A«.
- Connect hose from connection »A« of Y-branch to connection »II« of turbocharger tester - V.A.G 1397A- .
- Set turbocharger tester - V.A.G 1397A- to switch position »II« (gauge pressure measurement), and switch it on. The setting »II« must be visible.

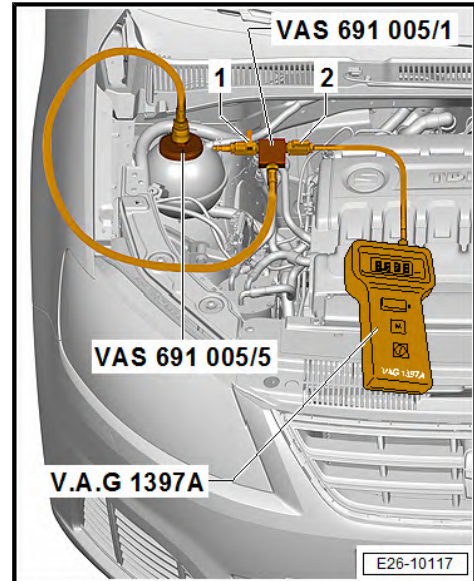

### Connecting charge air system tester - V.A.G 1687- :

- Remove engine cover.
- Free vacuum hoses -arrows-.
- Loosen hose clips -1, 2- and remove air pipe.

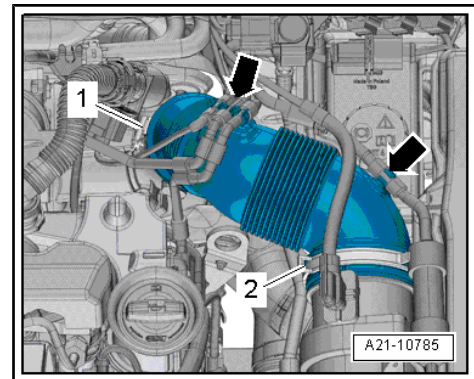

- Pull off crankcase breather pipe -arrow-.
- Seal connection with a bung -1- from engine bung set . Secure bung with a clip -2-.

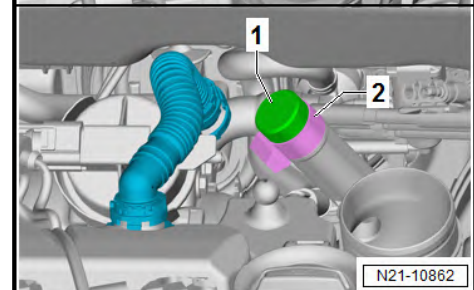
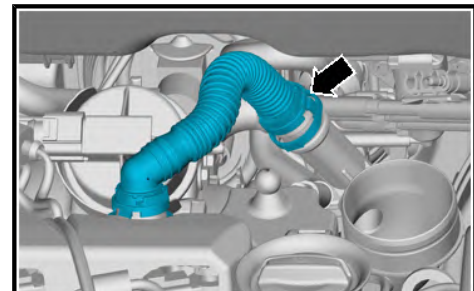

- Connect the adapter - V.A.G 1687/11- with -V.A.G 1687/15- to the exhaust gas turbocharger. Secure hose with hose clips.
- Connect charge air system tester - V.A.G 1687- to adapter.

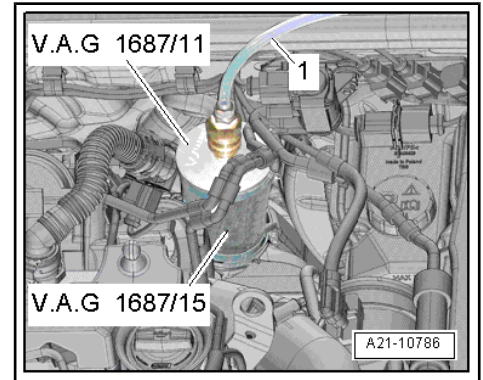

**Prepare charge air system tester - V.A.G 1687- as follows:**

- Pull pressure control valve -2- upwards, unscrew it completely, and close valves -3- and -4-.
- Using a commercially available connection piece, connect charge air system tester - V.A.G 1687- to compressed air -1-.

 **Note**

*If there is water in the inspection glass, -6- drain it via the drain plug.*

- Open valve -3-.
- Adjust pressure to 0.5 bar with pressure regulating valve -2-.
- Open valve -4- and wait until test circuit is full. If necessary readjust pressure to 0.5 bar.

 **Note**

*A small amount of air escapes through the valves and enters the engine and the exhaust gas recirculation cooler. Therefore a holding pressure test is not possible.*

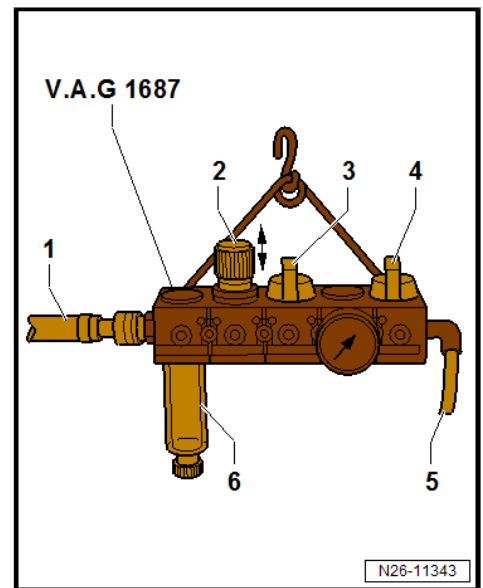

### Reading turbocharger tester - V.A.G 1397A- :

- Observe the turbocharger testing device for approximately 5 minutes.
- The pressure indicated by the turbocharger tester must not rise more than 0.025 bar.
- If the pressure on the turbocharger tester rises above 0.025 bar continuously, compressed air is leaking from the intake side into the cooling system. The charge air cooler has a leak. Renew charge air cooler.



#### Note

- ◆ *Subsequent warming of the coolant can cause a slight pressure increase of 0.025 bar. This slight increase does not indicate a leak.*
- ◆ *A vacuum can develop due to the cooling of the coolant. Vacuum is indicated using a »negative sign« in the tester for turbochargers . »Negative« values do not indicate a leak.*
- ◆ *If uncertainty remains, repeat the test. To do this, briefly open shut-off tap -1- to equalise pressure in the cooling system. If the charge air cooler has a leak, the pressure must rise steadily during every test.*

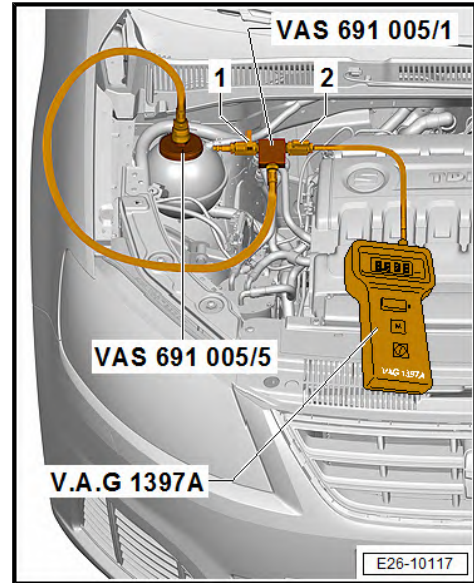

### Cleaning Y-branch - VAS 691 005/1- :



#### Note

*After the leakage test has been completed, the Y-branch - VAS 691 005/1- must be cleaned and any moisture which may have entered must be removed.*

- Insert cleaning nozzle -D- into hose on connection -A- of Y-branch .
- Fit test adapter - VAS 691 005/5- onto hose of connection -B-.
- Fit compressed air hose to connection -C-.
- Open shut-off taps and clean hose for approx. 15 seconds with compressed air.

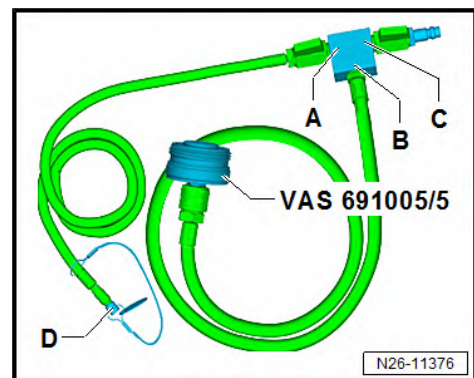

## 23 – Mixture preparation - injection

### 1 Injection system

⇒ [“1.1 Schematic overview - fuel system”, page 285](#)

⇒ [“1.2 Overview of fitting locations - injection system”, page 288](#)

⇒ [“1.3 Filling and bleeding fuel system”, page 293](#)

⇒ [“1.4 Checking fuel system for leaks”, page 294](#)

#### 1.1 Schematic overview - fuel system

⇒ [“1.1.1 Schematic overview - fuel system, version 1”, page 285](#)

⇒ [“1.1.2 Schematic overview - fuel system, version 2”, page 286](#)

##### 1.1.1 Schematic overview - fuel system, version 1



#### Note

- ◆ *Red = fuel supply*
- ◆ *Blue = fuel return*
- ◆ *Arrows show direction of fuel flow.*

**1 - Fuel filter**

- ❑ Assembly overview ⇒ Rep. gr. 20 ; Fuel filter; Assembly overview - fuel filter

**2 - High-pressure pump**

- ❑ Assembly overview ⇒ [page 356](#)

**3 - Fuel metering valve - N290-**

**4 - Fuel temperature sender - G81-**

**5 - Fuel pressure sensor - G247-**

- ❑ Assembly overview ⇒ [page 299](#)

**6 - Fuel rail**

- ❑ Assembly overview ⇒ [page 299](#)

**7 - Fuel pressure regulator valve - N276-**

- ❑ Assembly overview ⇒ [page 299](#)

**8 - Injectors**

- ❑ Assembly overview ⇒ [page 297](#)

**9 - Fuel tank**

- ❑ With fuel system pressurisation pump - G6-
- ❑ Assembly overview ⇒ Rep. gr. 20 ; Fuel tank; Fuel tank - Assembly overview

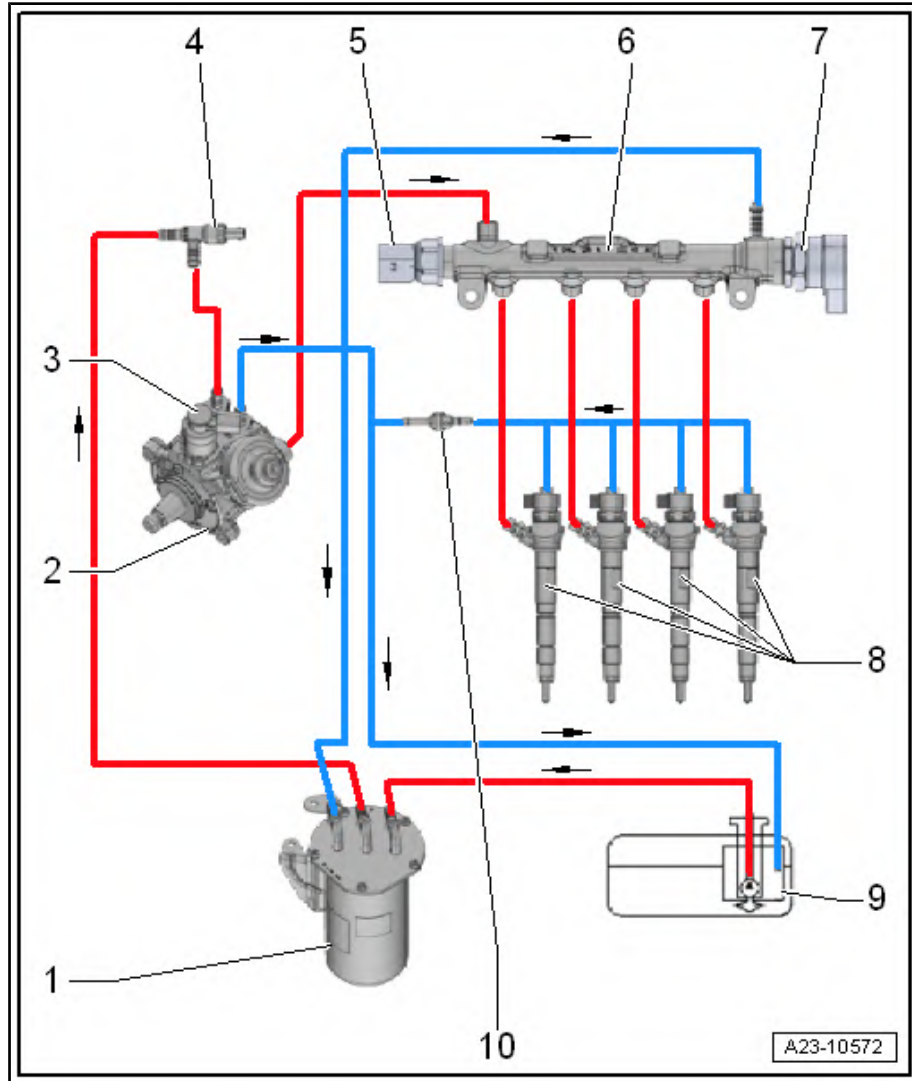

**10 - Throttle**

**1.1.2 Schematic overview - fuel system, version 2**

**i Note**

- ◆ Red = fuel supply
- ◆ Blue = fuel return
- ◆ Arrows show direction of fuel flow.

**1 - Fuel filter**

- Assembly overview ⇒ Rep. gr. 20 ; Fuel filter; Assembly overview - fuel filter

**2 - High-pressure pump**

- Assembly overview ⇒ [page 356](#)

**3 - Fuel metering valve - N290-**

**4 - Fuel temperature sender - G81-**

**5 - Fuel pressure sensor - G247-**

- Assembly overview ⇒ [page 299](#)

**6 - Fuel rail**

- Assembly overview ⇒ [page 299](#)

**7 - Fuel pressure regulator valve - N276-**

- Assembly overview ⇒ [page 299](#)

**8 - Injectors**

- Assembly overview ⇒ [page 297](#)

**9 - Fuel tank**

- With fuel system pressurisation pump - G6-
- Assembly overview ⇒ Rep. gr. 20 ; Fuel tank; Fuel tank - Assembly overview

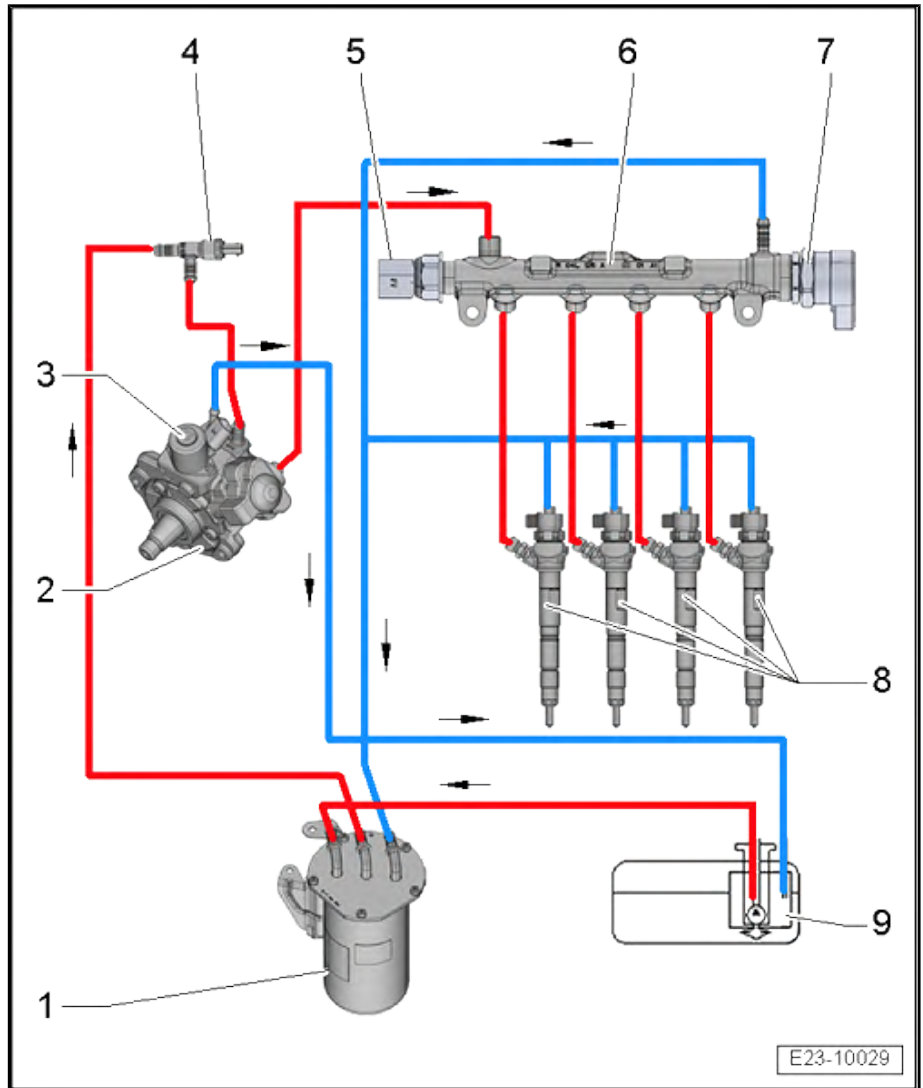

## 1.2 Overview of fitting locations - injection system

⇒ [“1.2.1 Overview of fitting locations - engine compartment”, page 288](#)

⇒ [“1.2.2 Overview of fitting locations - front view of engine”, page 290](#)

⇒ [“1.2.3 Overview of fitting locations - rear view of engine”, page 292](#)

⇒ [“1.2.4 Overview of fitting locations - electrical connectors”, page 293](#)

### 1.2.1 Overview of fitting locations - engine compartment

1 - Valve for the cylinder head coolant - N489-

- Location ⇒ [page 290](#)

2 - Injectors

- ◆ Cylinder 1 injector - N30-
- ◆ Cylinder 2 injector - N31-
- ◆ Cylinder 3 injector - N32-
- ◆ Cylinder 4 injector - N33-
  - Assembly overview ⇒ [page 297](#)

3 - Pressure differential sender - G505-

- If installed or not depends upon the exhaust emission regulations
- Assembly overview ⇒ [page 361](#)

4 - Pressure sensor 1 of exhaust gases - G450-

- vehicle-dependent
- Assembly overview ⇒ [page 361](#)

5 - Charge pressure actuator position sender - G581-

6 - Coolant temperature sensor - G62-

- Assembly overview ⇒ [page 194](#)

7 - Solenoid valve for charge pressure limiting - N75-

- Electrical connector for charge pressure control solenoid valve - N75- ⇒ [page 293](#)

8 - Air mass gauge - G70-

- Location ⇒ [page 293](#)
- Assembly overview ⇒ [page 319](#)

9 - Engine control unit - J623-

- Removing and installing ⇒ [page 350](#)

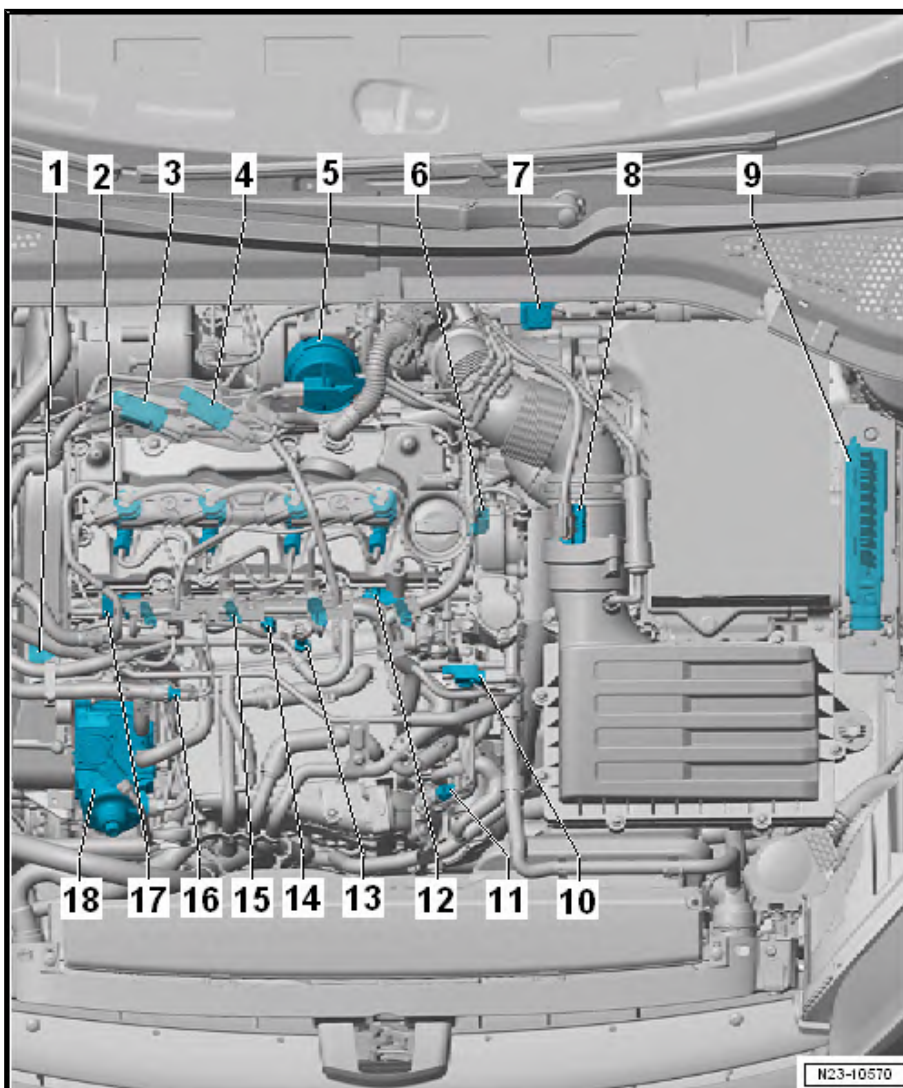

#### 10 - Charger pressure sensor - G31-

- Assembly overview ⇒ [page 276](#)

#### 11 - Intake air temperature sensor - G42-

- Assembly overview ⇒ [page 323](#)

#### 12 - Fuel pressure regulator valve - N276-

- Assembly overview ⇒ [page 299](#)

#### 13 - Charge air temperature sender after charge air cooler - G811-

- Assembly overview ⇒ [page 323](#)

#### 14 - Hall sender - G40- (camshaft position sensor)

- Camshaft position sensor
- Assembly overview ⇒ [page 443](#)

#### 15 - Glow plugs

- ◆ Glow plug 1 - Q10-
- ◆ Glow plug 2 - Q11-
- ◆ Glow plug 3 - Q12-
- ◆ Glow plug 4 - Q13-
  - On some vehicles, a combustion chamber pressure sensor is integrated in the glow plug of cylinder 3; glow plug 3 - Q12- with cylinder 3 combustion chamber pressure sensor - G679-
  - Assembly overview ⇒ [page 443](#)

#### 16 - Fuel temperature sender - G81-

- In fuel supply line
- Removing and fitting ⇒ [page 347](#)

#### 17 - Fuel pressure sensor - G247-

- Assembly overview ⇒ [page 299](#)

#### 18 - High-pressure pump

- With fuel metering valve - N290- (do not open)
- Assembly overview ⇒ [page 356](#)

#### Accelerator position sender - G79- and accelerator position sender 2 - G185-

- ◆ In accelerator pedal module
- 2 - Electrical connector for accelerator pedal module

#### Note

*The accelerator position sender - G79- and accelerator position sender 2 - G185- are integrated in the accelerator pedal module and cannot be renewed individually.*

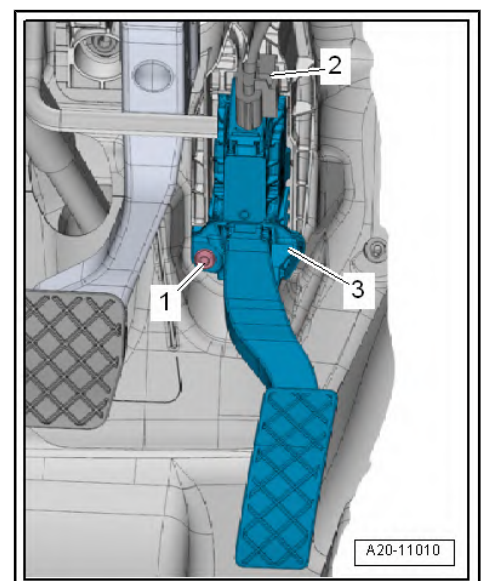

### Installation location of brake light switch - F- / brake pedal switch - F63-

- ◆ On brake servo in engine compartment.

1 - Brake light switch - F- / Brake pedal switch - F63-

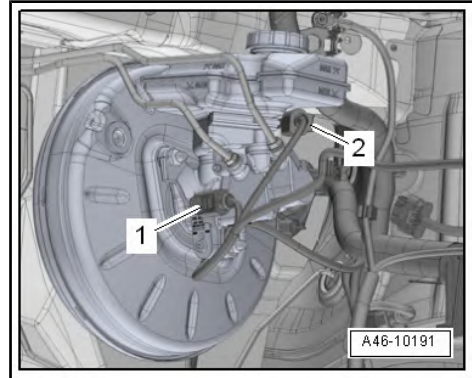

### Fitting location of gearbox neutral position sender - G701-

- At front left of gearbox.

1 - Electrical connector for gearbox neutral position sender - G701-

2 - Electrical connector for reversing light switch - F4-

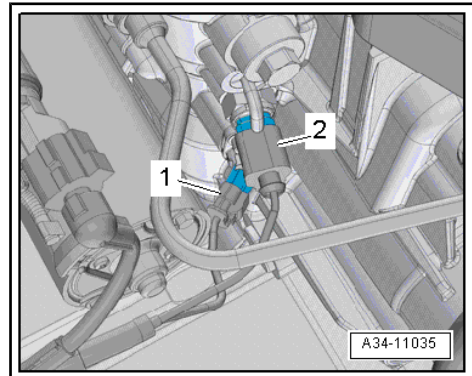

### Fitting location of exhaust flap control unit - J883-

- In front exhaust pipe

Removing and installing ⇒ [page 366](#) .

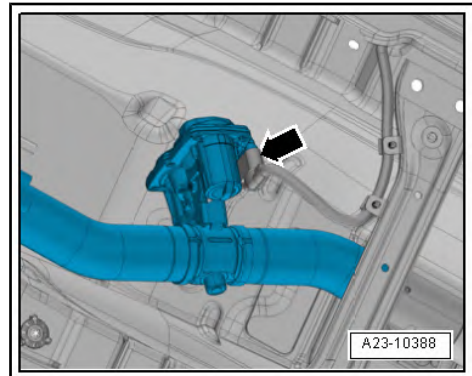

### Fitting location of coolant valve for cylinder head - N489-

- -Item 1- at top of coolant pump

Removing and installing ⇒ [page 176](#) .

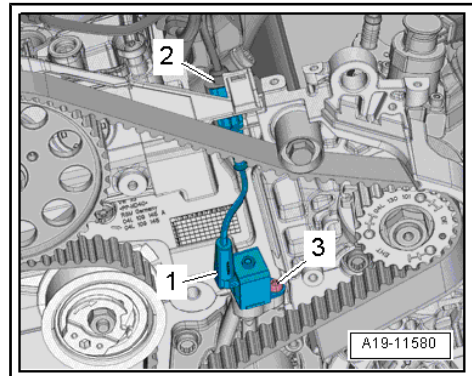

## 1.2.2 Overview of fitting locations - front view of engine

**1 - Valve for oil pressure control - N428-**

- Removing and fitting  
 ⇒ [page 174](#)

**2 - Exhaust gas recirculation valve 1 - GX5-**

- vehicle-dependent
- Consisting of: Potentiometer for exhaust gas - G212- and control motor for exhaust gas - V338-
- Assembly overview  
 ⇒ [page 420](#)

**3 - Valve 1 for variable distribution - N205-**

- vehicle-dependent
- Assembly overview  
 ⇒ [page 137](#)

**4 - Throttle valve control mechanism - J338-**

- With throttle valve potentiometer - G69-
- Assembly overview  
 ⇒ [page 323](#)

**5 - Oil pressure switch for reduced oil pressure - F378-**

- Assembly overview  
 ⇒ [page 169](#)

**6 - Oil pressure switch - F1-**

- Assembly overview  
 ⇒ [page 169](#)

**7 - Engine speed sensor - G28-**

- Assembly overview  
 ⇒ [page 443](#)

**8 - Charge air cooling pump - V188-**

- Assembly overview ⇒ [page 188](#)

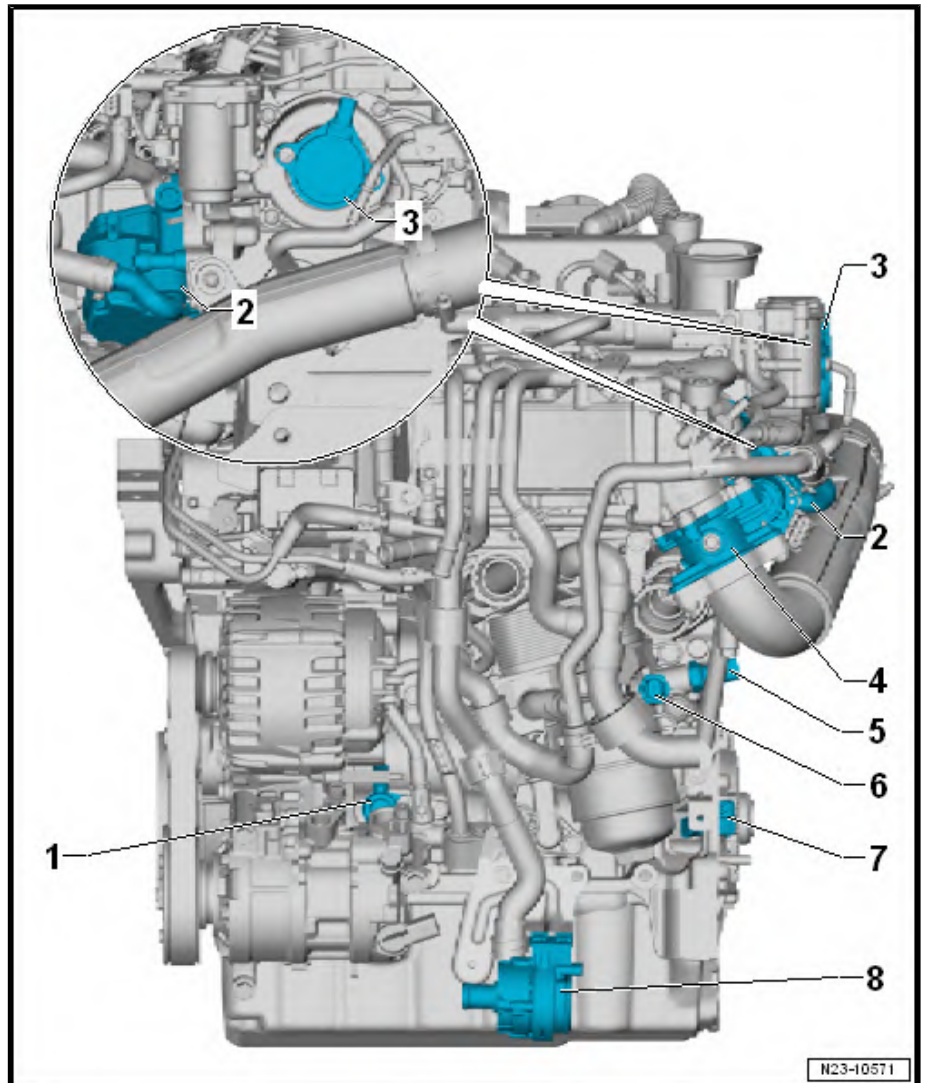

## 1.2.3 Overview of fitting locations - rear view of engine

### 1 - Oil level/oil temperature sensor - G266-

- Assembly overview  
⇒ [page 159](#)

### 2 - Exhaust gas recirculation valve 2 - GX6-

- vehicle-dependent
- Consisting of: Potentiometer 2 for exhaust gas - V339- and control motor 2 for exhaust gas - G466-
- Assembly overview  
⇒ [page 411](#)

### 3 - Exhaust gas temperature sender 1 - G235-

- Assembly overview  
⇒ [page 361](#)

### 4 - Exhaust gas temperature sender 2 - G448-

- If fitted
- Assembly overview  
⇒ [page 361](#)
- Electrical connector of the exhaust gas temperature sender 2 - G448-  
⇒ [page 293](#)

### 5 - Lambda sensor 1 before catalytic converter - GX10-

Comprising: lambda probe - G39- with lambda probe heating - Z19- .

- Exploded view  
⇒ [page 361](#)

### 6 - Exhaust gas temperature sender 3 - G495-

- Assembly overview ⇒ [page 361](#)

### 7 - Exhaust gas temperature sender 4 - G648-

- If fitted
- Exploded view ⇒ [page 361](#)

### 8 - Lambda probe 1 after catalytic converter - GX7-

Consisting of: Lambda probe after catalytic converter - G130- and Heater for lambda probe 1, after catalytic converter - Z29-

- If fitted
- Exploded view ⇒ [page 361](#)
- Fitting location of connector for Lambda probe 1 after catalytic converter - GX7- ⇒ [page 293](#) .

### 9 - Auxiliary pump for heating - V488-

- Assembly overview ⇒ [page 190](#)

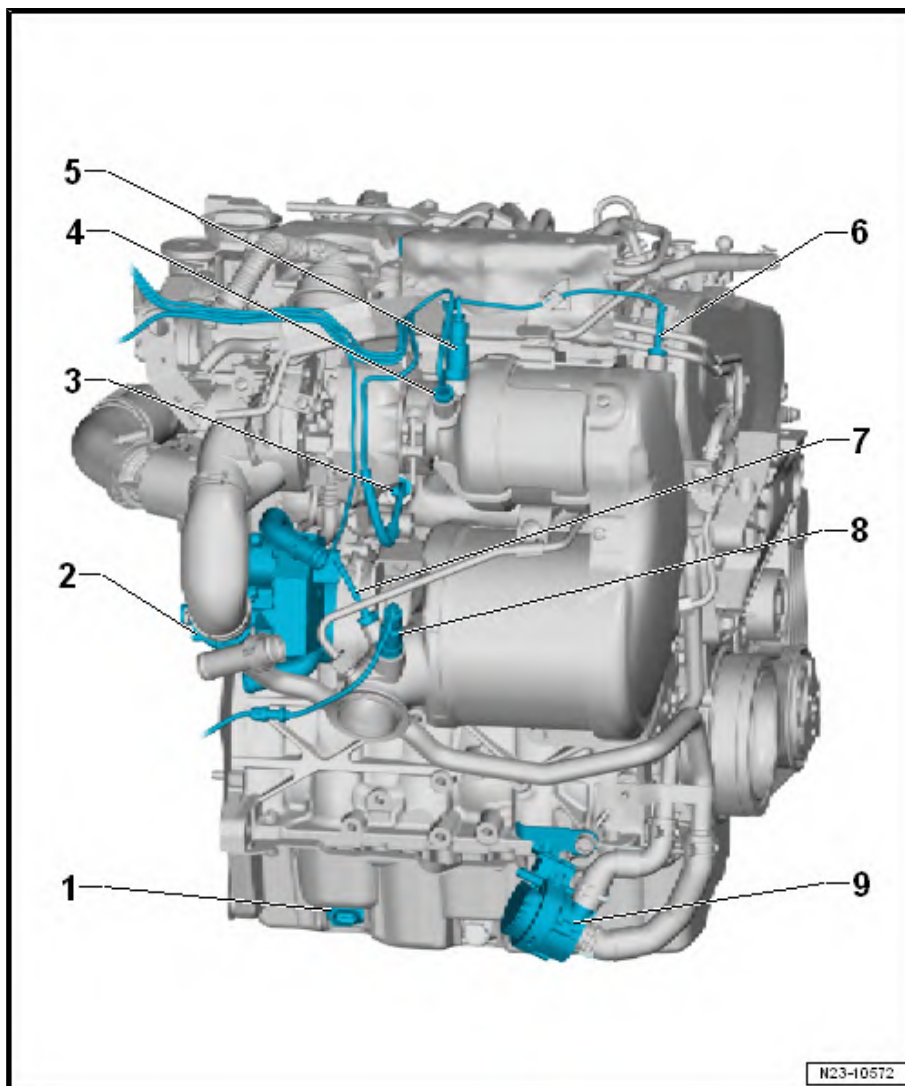

## 1.2.4 Overview of fitting locations - electrical connectors

⇒ Fig. ““Leon, Leon ST Variant 1””, page 293

⇒ Fig. ““Leon, Leon ST Variant 2””, page 293

⇒ Fig. ““Fitting location of connector for Lambda probe 1 after catalytic converter -GX7-””, page 293

### Leon, Leon ST Variant 1

- 1 - Solenoid valve for charge pressure limiting - N75-
- 2 - Exhaust gas temperature sender 4 - G648-
- 3 - Exhaust gas temperature sender 3 - G495-
- 4 - Lambda sensor 1 before catalytic converter - GX10-
- 5 - Air mass gauge - G70-

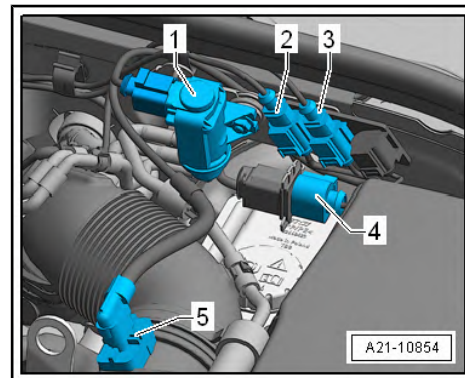

### Leon, Leon ST Variant 2

– Disconnect electrical connections, take cable out of the brackets and place over the engine.

- 1 - For exhaust gas temperature sender 4 - G648-
- 2 - For exhaust gas temperature sender 3 - G495-
- 3 - For exhaust gas temperature sender 2 - G448-
- 4 - For Lambda probe 1 before catalytic converter - GX10- .

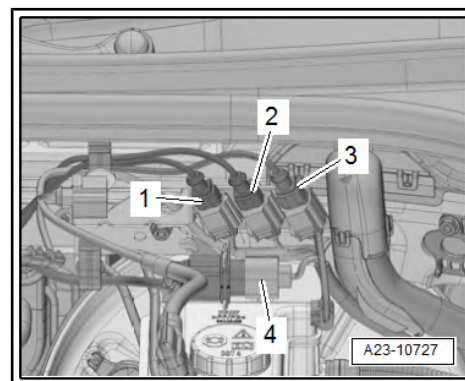

### Fitting location of connector for Lambda probe 1 after catalytic converter - GX7-

- Beneath the left-hand central element of the powertrain guard -arrow-

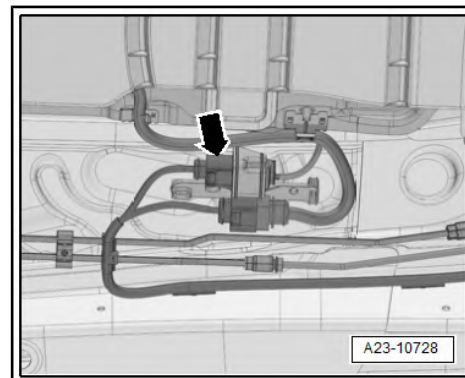

## 1.3 Filling and bleeding fuel system



### Caution

*The high-pressure pump has very close tolerances and must not be allowed to run without fuel. To prevent this and to enable the engine to start quickly after parts have been renewed, it is important to observe the following:*

- ◆ *If components of the fuel system between the fuel tank and the high-pressure pump have been removed or renewed, the fuel system must be filled and bled before the engine is started for the first time.*

Special tools and workshop equipment required

◆ Vehicle diagnosis tester

**Proceed as follows to fill high-pressure pump with fuel:**

- There must be sufficient fuel in the tank.
- Connect vehicle diagnostic tester .
- Switch on ignition and select the following menu item in the vehicle diagnostic and service information system :
- ◆ Fuel system: bleeding of air
- The fuel pump starts running.
- The fuel pump must run for approx. 3 minutes to ensure that the high-pressure pump is filled with sufficient fuel.
- Start the engine after filling the fuel system.
- Let the engine run for a few minutes at average speed and then turn it off again.
- Check that the fuel system is completely sealed.
- Delete event memory entry with the vehicle diagnostics tester .
- Then test drive the vehicle, accelerating to full throttle at least once.
- Then inspect high-pressure section of fuel system again for leaks.



**Note**

*If there is any air left in the fuel system, the engine may switch to the backup mode ('emergency running' mode) during the road test. Switch off the engine and erase the event memory. Then continue road test.*

- Delete event memory entry with the vehicle diagnostics tester .

## 1.4 Checking fuel system for leaks

- Start engine and run at idling speed for a few minutes. Do not press the accelerator at this time and then shut off the engine again (fuel system bleeds itself).
- Check fuel system for leaks .
- If leaks are found although the connections have been tightened to the correct torque, the relevant component must be renewed.
- Then test drive the vehicle, accelerating to full throttle at least once.
- Then inspect high-pressure section of fuel system again for leaks.

## 2 Vacuum system

⇒ [“2.1 Connection diagram - vacuum system”, page 295](#)

⇒ [“2.2 Vacuum system: checking”, page 295](#)

### 2.1 Connection diagram - vacuum system

- 1 - Vacuum line
  - To the oil pump  
⇒ [page 159](#)
- 2 - Non-return valve
  - Observe installation position
- 3 - Rocker finger cover
  - With vacuum reservoir
- 4 - Vacuum unit
  - For charge pressure regulation
  - On turbocharger.
- 5 - Control pipe for vacuum
  - From charge pressure control solenoid valve - N75- to vacuum unit on turbocharger
- 6 - Solenoid valve for charge pressure limiting - N75-
- 7 - To brake servo
- 8 - Non-return valve
  - Observe installation position
- 9 - Bleeder hose
- 10 - To air filter housing
- 11 - To vacuum pump
  - To the oil pump  
⇒ [page 159](#)

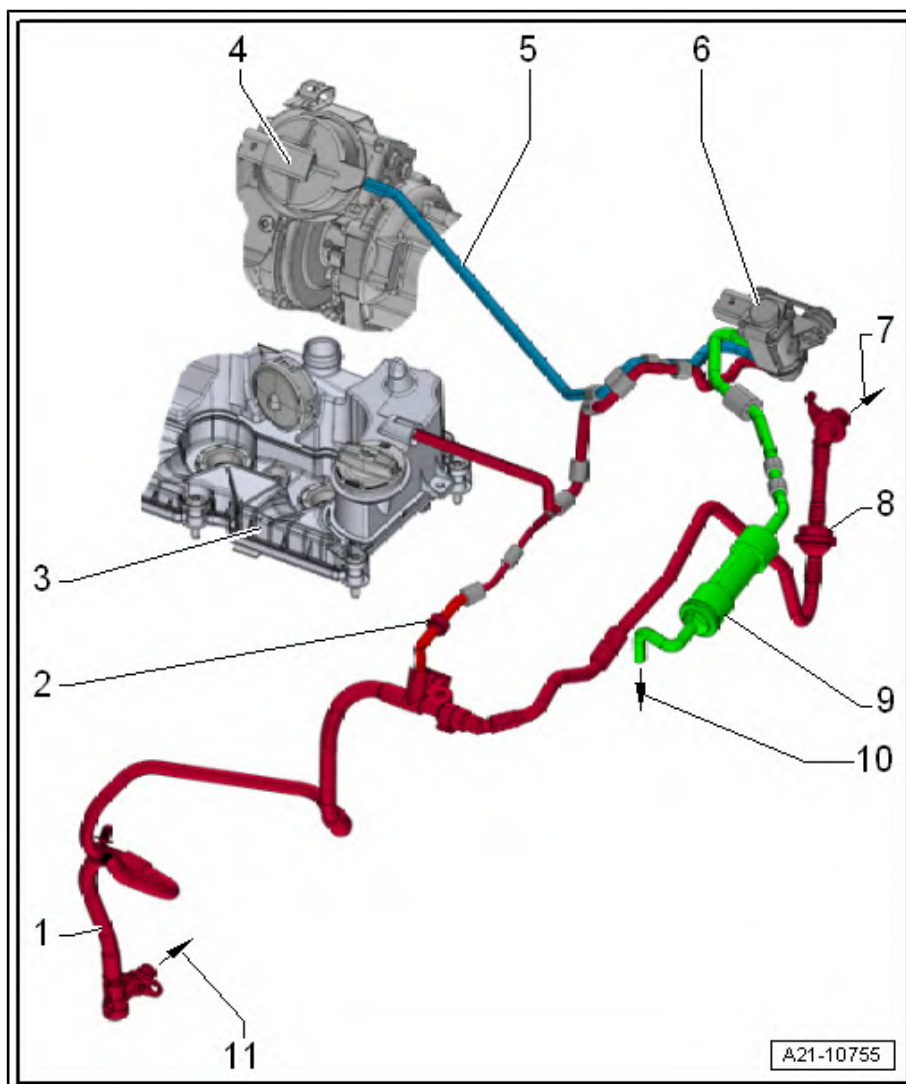

### 2.2 Vacuum system: checking

Special tools and workshop equipment required

◆ Hand vacuum pump - VAS 6213-

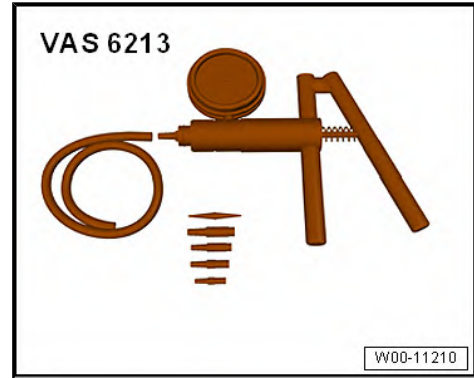

**Operation process**

- Check all vacuum lines in the complete vacuum system for:
  - ◆ Cracks
  - ◆ Traces of animal bites
  - ◆ Kinked or crushed lines
  - ◆ Lines porous or leaking
- Check vacuum line to solenoid valve and from solenoid valve to corresponding component.
- If an entry is stored in the event memory, check all vacuum lines leading to the corresponding component and also check the remaining vacuum lines leading to other components.
- If it is not possible to build up a vacuum with the hand vacuum pump - VAS 6213- or if the vacuum pressure drops again immediately, check the hand vacuum pump and connecting hoses for leaks.

### 3 Injectors/high-pressure accumulator (rail)

⇒ [“3.1 Assembly overview - injectors”, page 297](#)

⇒ [“3.2 Exploded view - high-pressure reservoir \(rail\)”, page 299](#)

⇒ [“3.3 Performing adaption of correction values for injectors”, page 300](#)

⇒ [“3.4 Checking injectors”, page 300](#)

⇒ [“3.5 Checking return flow rate of injectors with engine running”, page 301](#)

⇒ [“3.6 Checking return flow rate of injectors at starter cranking speed”, page 304](#)

⇒ [“3.7 Check the open nozzle units”, page 306](#)

⇒ [“3.8 Removing and installing injectors”, page 308](#)

⇒ [“3.9 Removing and installing high-pressure pipes”, page 313](#)

⇒ [“3.10 Removing and installing high-pressure reservoir \(rail\)”, page 315](#)

#### 3.1 Assembly overview - injectors

##### 1 - Oil seal

- In cylinder head cover
- Must be renewed if removed ⇒ [page 92](#) ,

##### 2 - Copper seal

- Renew following removal

##### 3 - O-ring

- Renew following removal

##### 4 - Injector

- If they are to be reinstalled, the injectors and high-pressure lines must always be reinstalled on the same cylinder.
- Removing and fitting ⇒ [page 308](#)

##### 5 - O-ring

- Renew following removal

##### 6 - Fuel return

- To fuel tank
- Must not be kinked, damaged or clogged
- Do not dismantle
- Fill and bleed fuel system after renewing ⇒ [page 293](#)

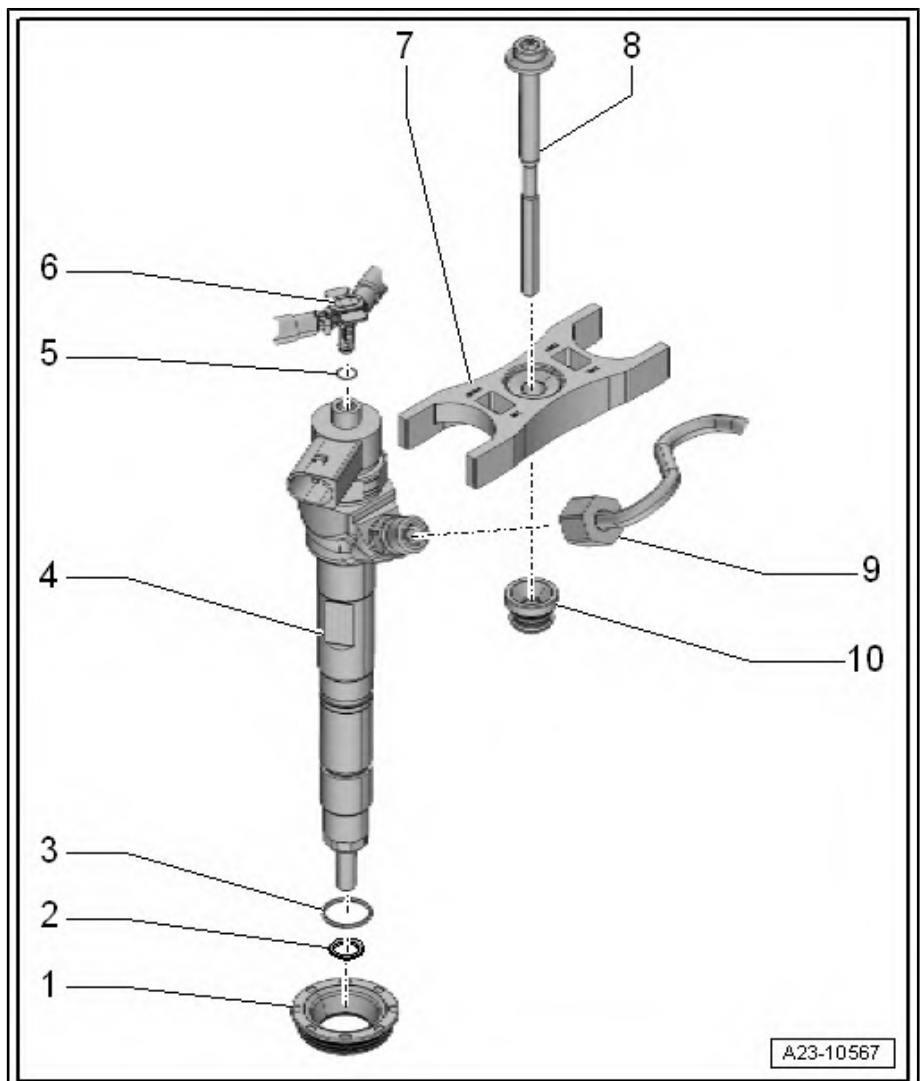

## 7 - Clamping piece

 **Caution**

*Risk of damage to engine.*

*When installing a new base engine, it is essential that the clamping pieces for the injectors are tightened to the specified torque*

*⇒ **Item 8 (page 298)** after installing the high-pressure pipes. The clamping pieces are only secured »hand-tight« at the factory so the injectors can be aligned during installation.*

- Installation position ⇒ [Fig. ""Installation position clamping piece, variant 1"" , page 298](#)
- Installation position, engine codes  
⇒ [Fig. ""Installation position of the clamping piece, variant 2, for the engines CXXA and CXXB"" , page 299](#)

## 8 - Bolt.

- Renew following removal
- 8 Nm + 270°

## 9 - High-pressure pipe

- Between high-pressure reservoir and injectors
- Observe all instructions for installing high-pressure pipes ⇒ [page 313](#)
- Install so that component is not stressed.
- 28 Nm

## 10 - Nipple/nozzle/grommet

- In cylinder head cover
- Renew if damaged.

### Installation position clamping piece, variant 1

- Each clamping piece secures two injectors.
- The bulge -arrow- of the clamping piece should point downwards.

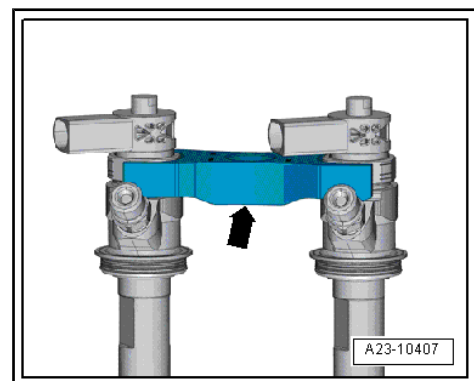

**Installation position of the clamping piece, variant 2, for the engines CXXA and CXXB**

- Each clamping piece secures two injectors.
- The thick part -arrow- of the clamping piece -1- points upwards.

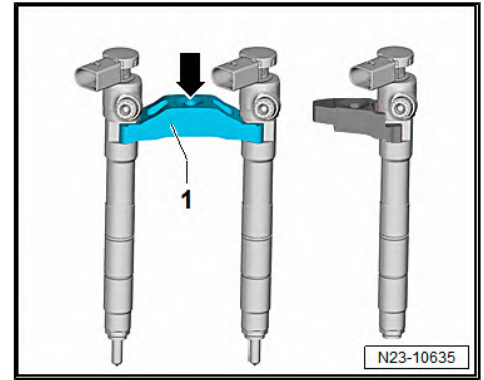

**3.2 Exploded view - high-pressure reservoir (rail)**

**1 - Fuel pressure sensor - G247-**

- Removing and fitting ⇒ [page 338](#)
- Can be re-used ⇒ [page 339](#)
- 100 Nm

**2 - High-pressure pipe**

- Between high-pressure reservoir and injectors
- Observe all instructions for installing high-pressure pipes ⇒ [page 313](#)
- 28 Nm

**3 - High-pressure accumulator (Common Rail)**

- Removing and fitting ⇒ [page 315](#)

**4 - Bolt.**

- 20 Nm

**5 - O-ring**

- Renew following removal

**6 - Fuel pressure regulator valve - N276-**

- Removing and fitting ⇒ [page 331](#)
- Always renew if removed
- 80 Nm
- after renewing, re-adapt the learnt values in "Guided Functions" Vehicle diagnostic and service information system

**7 - Fuel return hose**

**8 - Fuel return line**

**9 - Bolt.**

- 8 Nm

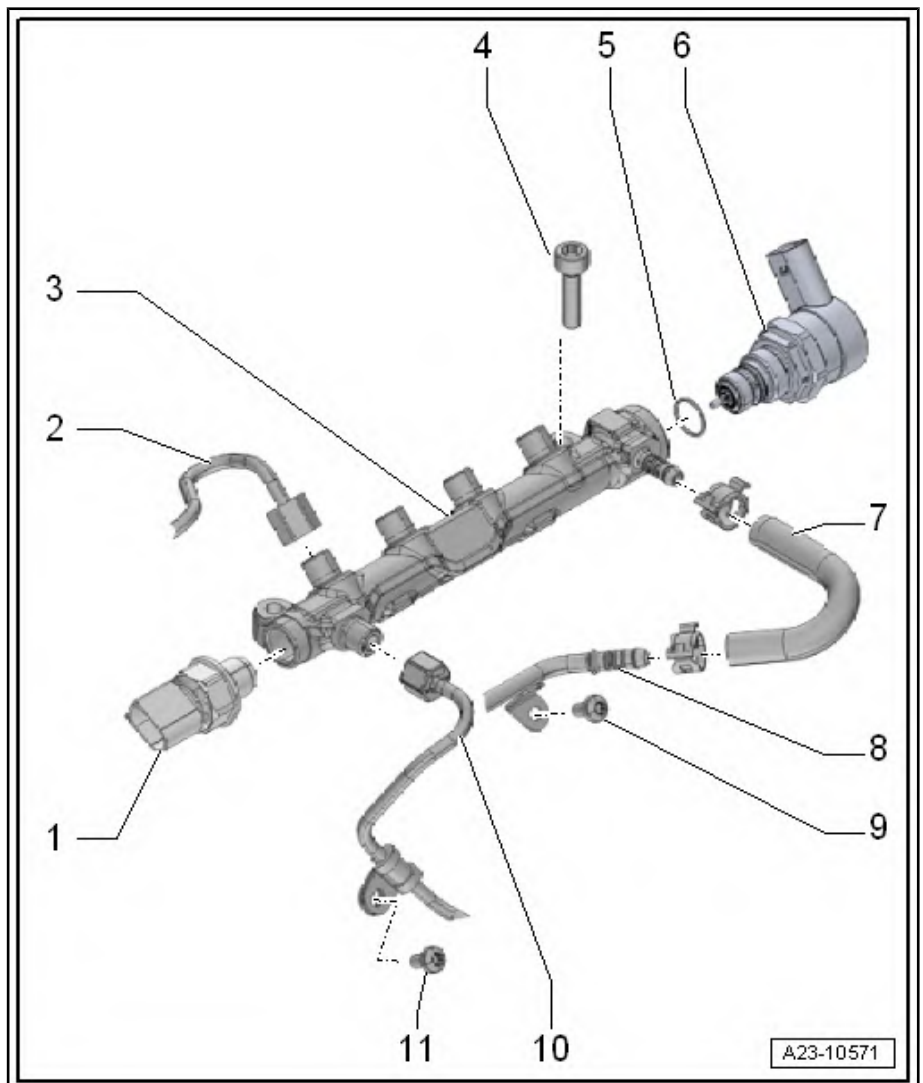

### 10 - High-pressure pipe

- Between high-pressure pump and high-pressure accumulator
- Observe all instructions for installing high-pressure pipes ⇒ [page 313](#)
- 28 Nm

### 11 - Bolt.

- 8 Nm

## 3.3 Performing adaption of correction values for injectors

- ◆ The “Injector delivery calibration values” function serves to correct the injection rates for each cylinder of a common rail system individually across the entire operating range.
- ◆ The 7-digit adaption values are marked on each injector. The values may consist of letters and/or numbers.



#### Injector (view from above)

- 1 - Adaption value (checksum; details in illustration are only an example)
  - 2 - DATA Matrix Code
  - 3 - Part number
- ◆ After renewing an injector, the adaptation value must be written into the engine control unit.
  - ◆ When a new engine control unit is installed, the “Adaption values for injectors” must be written into the new control unit.
  - ◆ Additionally check that the “injector delivery calibration values” are correctly entered for all the other injectors. Do NOT attempt to re-enter these values if the correct values are already stored in the engine control unit.
  - ◆ The adaption procedure is described in the “Guided Fault Finding”. (The procedure is also described under “Guided Functions”.) For this purpose, use Vehicle diagnostic and service information system .

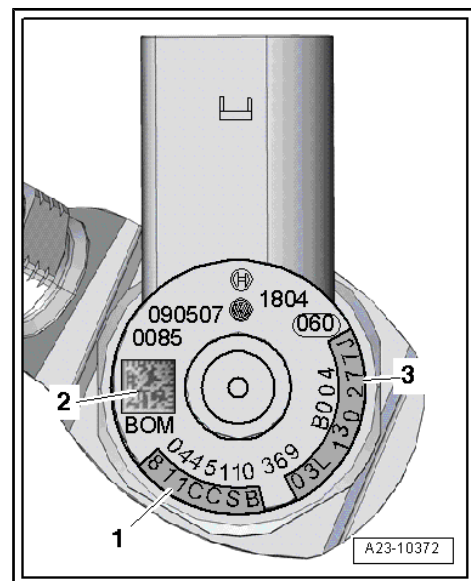

## 3.4 Checking injectors

There are 3 different methods for testing the injectors.

- ◆ ⇒ [“3.3 Performing adaption of correction values for injectors”, page 300](#)
- ◆ ⇒ [“3.5 Checking return flow rate of injectors with engine running”, page 301](#)
- ◆ ⇒ [“3.6 Checking return flow rate of injectors at starter cranking speed”, page 304](#)

### 3.5 Checking return flow rate of injectors with engine running

#### A - Checking return flow rate of all injectors

##### Special tools and workshop equipment required

- ◆ Measuring container, fuel-resistant

##### Operation process

- Remove engine cover. ⇒ [page 56](#)
- Disconnect hose connection -2- at fuel return line.



#### Caution

*Risk of malfunctions caused by dirt.*

- ◆ *Take into account: ⇒ "3.1 Cleaning rules", page 13 .*

- Seal the return line connection using a blind plug -1-.
- Hold end of fuel return hose -2- (lengthen if necessary) in a measuring container to measure the total return flow rate.
- Start engine and let it idle for 2 minutes.
  - Specification for 2 minutes: from 0 ml to 50 ml
- If the specified amount is achieved, increase the engine speed to between 2,000 and 2,500 rpm for approx. 2 minutes and then check the amount of fuel returned.
  - Specification for 2 minutes: less than 250 ml.

If specification is exceeded, this indicates that one or more injectors are defective. Check return flow rate from each injector individually.

#### B - Checking return flow rate of individual injectors

##### Special tools and workshop equipment required

- ◆ Hose clamps, up to 25 mm - 3094-

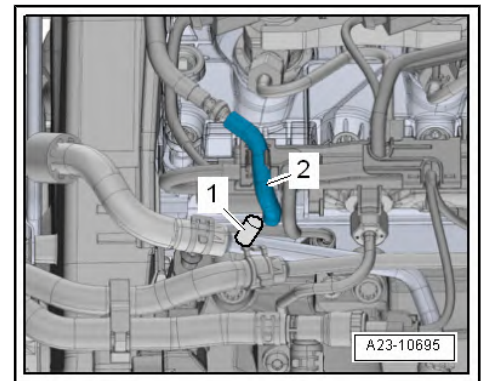

- ◆ Adapter C6 from return flow meter - VAS 6684-

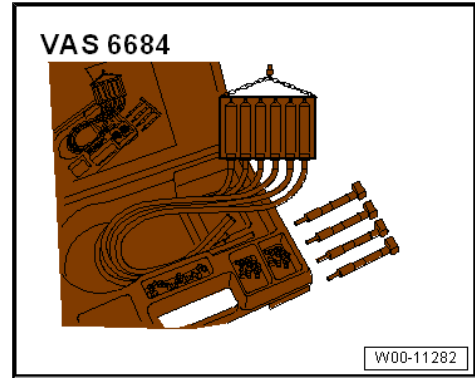

#### For engine codes CXXA, CXXB

- ◆ Adapter C7 for return flow meter - VAS 6684- for engine codes CXXA, CXXB

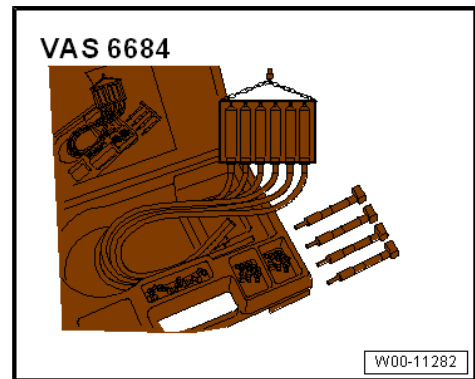

- ◆ Front-end hook - 3370-



#### Operation process



#### Note

*Each injector normally has a relatively low return flow rate. If the return flow rate at one injector is relatively high compared to the other injectors, that injector is probably defective.*



#### Caution

**Risk of malfunctions caused by dirt.**

- ◆ **Take into account:** ⇒ ***“3.1 Cleaning rules”, page 13***

- Clean all return line connections (e.g. with commercial cleaning solution etc.) before removing.

- Dry all components after cleaning.
- Clamp off the fuel return hose -arrow- using hose clamp up to 25 mm - 3094- .
- Remove the sound insulation.

 **Note**

*No dirt must be allowed to get into the disconnected return lines or the open connections on the injectors.*

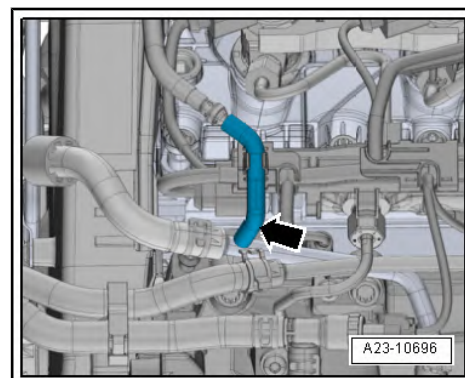

**Vehicles with engine codes CXXA, CXXB**

- Suspend the hook for front end - 3370- into the lower recess -arrow-.
- Unlock the middle section of the connections of the return line in -direction of arrow-.

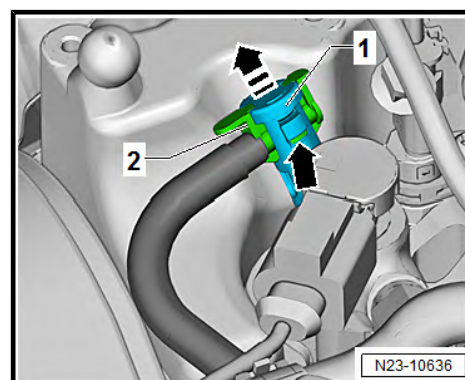

**Vehicles with other engine codes**

- Pull release tabs upwards -arrows- and pull return line connections off injectors.

**Continued for all vehicles:**

- Connect adapter for return flow meter - VAS 6684- securely to the connections of the return lines of the 4 injection units.

Adapter C7 - For engine code CXXA and CXXB

Adapter C6 - For all other engine codes

- Connect hoses of return flow meter -VAS 6684- to adapters.
- Start engine and allow to idle for several minutes.

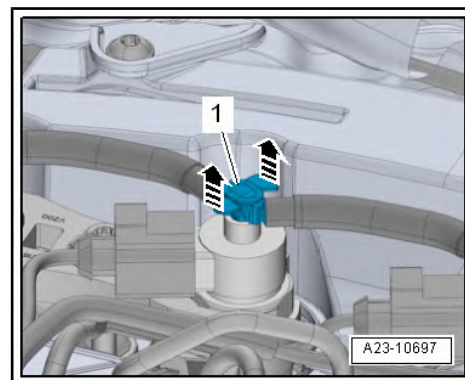

**Caution**

***Risk of damage to injectors after return lines have been pulled off!***

- ◆ ***Do NOT press the accelerator during this test; the engine must only run at idling speed.***

- When the engine is warm and running at idling speed, the return flow rates at each of the 4 return lines must not differ by more than a small amount (example -1-).

- If one injector has a significantly higher return flow rate than the others (example -2-), it must be renewed ⇒ [page 308](#) .

#### Installing fuel return lines

- Push return line connections carefully onto injectors. The catch should engage audibly. Then press release pin down carefully.
- Install engine cover panel ⇒ [page 56](#) .
- Check fuel system for leaks ⇒ [page 294](#) .

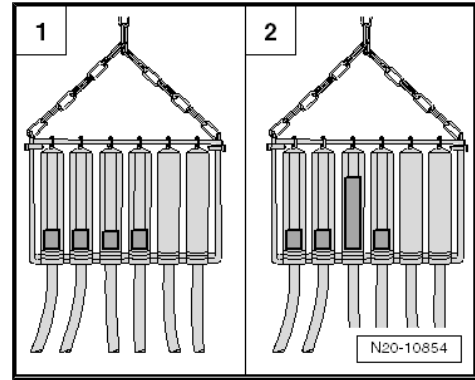

### 3.6 Checking return flow rate of injectors at starter cranking speed



#### Note

*If it is not possible to start engine, the return flow rate of injectors can be checked with the starter motor speed.*

#### Special tools and workshop equipment required

- ◆ Adapter C6 from return flow meter - VAS 6684-

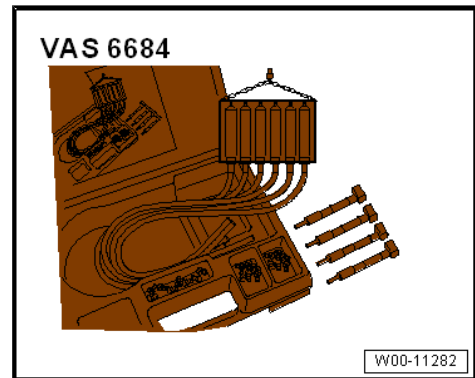

- ◆ Adapter C7 for return flow meter - VAS 6684- for engine codes CXXA, CXXB
- ◆ Front-end hook - 3370- for engine codes CXXA, CXXB



## Operation process

### Note

*Each injector normally has a relatively low return flow rate. If the return flow rate at one injector is relatively high (compared to the other injectors), that injector is probably defective.*

- Remove engine cover. ⇒ [page 56](#)



### Caution

*Risk of malfunctions caused by dirt.*

- ◆ **Observe** ⇒ ***“3.1 Cleaning rules”, page 13***.

- Clean all return line connections (with commercial cleaning solution etc.) before removing.
- Dry all components after cleaning.
- Remove the sound insulation.

### Note

*No dirt must be allowed to get into the disconnected return lines or the open connections on the injectors.*

### Vehicles with engine codes CXXA, CXXB

- Suspend the hook for front end - 3370- into the lower recess -arrow-.
- Unlock the middle section of the connections of the return line in -direction of arrow-.

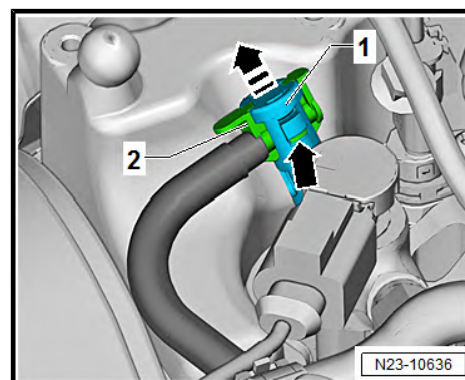

### Vehicles with other engine codes

- Pull release tabs upwards -arrows- and pull return line connections off injectors.

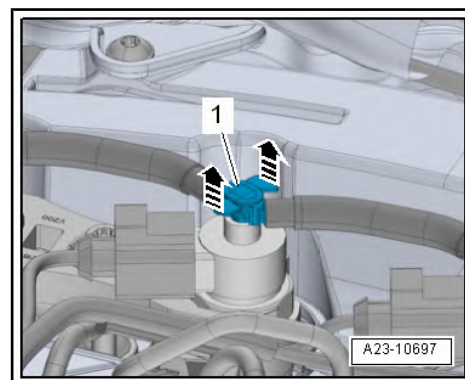

**All vehicles (continued):**

- Unplug electrical connector on -2- fuel pressure regulating valve - N276- -item 1-.



**Note**

*This prevents fuel from being injected when operating starter.*

- Clean the return flow meter - VAS 6684- and blow out with compressed air.
- Connect adapter securely to the connections of the return lines of the 4 injection units.

Adapter C7 - For engine code CXXA and CXXB

Adapter C6 - For all other engine codes

- Connect hoses of return flow meter -VAS 6684- to adapters.
- Operate starter three times. Allow 20 seconds to elapse after every start attempt, in order to avoid the starter from overheating.
- Specification of return flow rate: 0 ml
- If fuel comes out of an injector, that injector must be renewed.
- Attach electrical connector of fuel pressure regulating valve - N276- .

**Installing fuel return lines**

- Press return line connections onto injectors until they engage audibly.
- Then push down the bar on both sides.
- Check fuel system for leaks => [page 294](#) .
- Install engine cover panel => [page 56](#) .
- Delete event memory entry with the vehicle diagnostics tester .

**3.7 Check the open nozzle units**

**Special tools and workshop equipment required**

- ◆ Vehicle diagnosis tester
- ◆ Hand vacuum pump - VAS 6213-

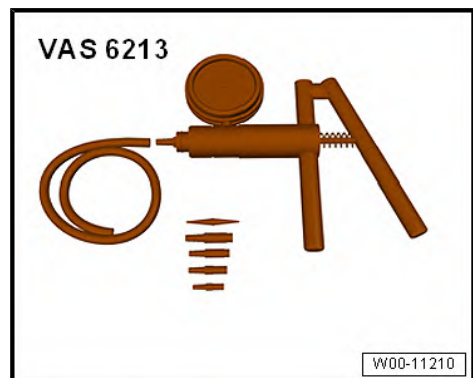
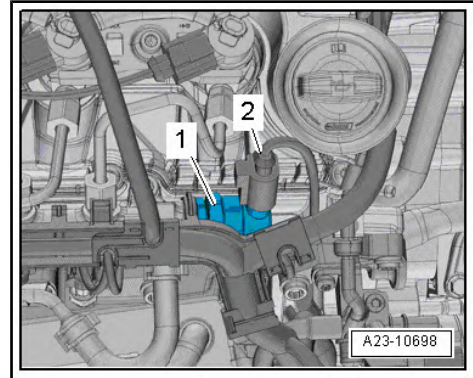

- ◆ Adapter C6 from return flow meter - VAS 6684-

**For engine codes CXXA, CXXB**

◆ Front-end hook - 3370-

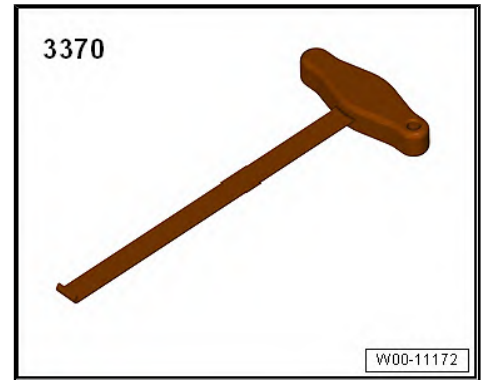

**Operation process**

- Delete entry in event memory using the Vehicle diagnostic and service information system .
- Remove engine cover. ⇒ [page 56](#)

 **Caution**

*Risk of malfunctions caused by dirt.*

◆ *Take into account: ⇒ ["3.1 Cleaning rules", page 13](#)*

- Clean all connections (with commercial cleaning solution or similar) before removing.

 **Note**

- ◆ *Make sure all parts are clean; no dirt must be allowed to enter the fuel system.*
- ◆ *Check all cylinders in turn.*

- Dry all components after cleaning.

Start with cylinder 1.

- Remove the sound insulation.

 **Note**

*No dirt must be allowed to get into the disconnected return lines or the open connections on the injectors.*

**Vehicles with engine codes CXXA, CXXB**

- Suspend the hook for front end - 3370- into the lower recess -arrow-.
- Unlock the middle section of the connections of the return line in -direction of arrow-.

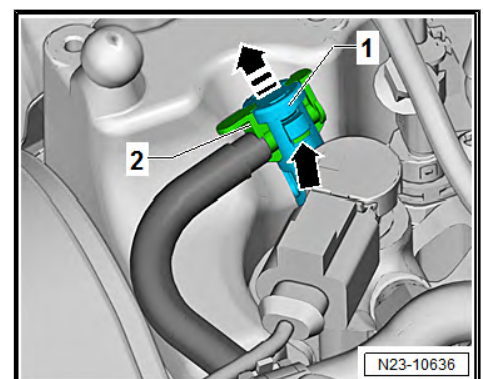

### Vehicles with other engine codes

- Pull release tabs upwards -arrows- and pull return line connections off injectors.

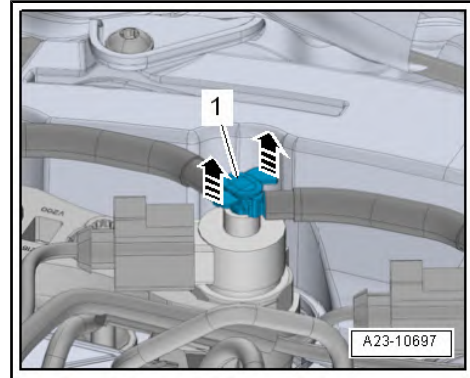

### Continued for all vehicles:

- Clean the return flow meter - VAS 6684- and blow out with compressed air.
- Connect adapter to return line connection of injector to be tested after adapter has been cleaned.

Adapter C7 - For engine code CXXA and CXXB

Adapter C6 - For all other engine codes

- Generate a vacuum of -500 mbar using the hand vacuum pump - VAS 6213- .

If the vacuum reading remains the same for 30 seconds, the injector is OK.

If injectors are defective, the pressure drops within 2 ... 3 seconds.

Repeat check is necessary, observe pressure loss at hand-operated vacuum pump - VAS 6213- .

- Renew faulty injectors ⇒ [page 308](#) .
- Install engine cover panel ⇒ [page 56](#) .

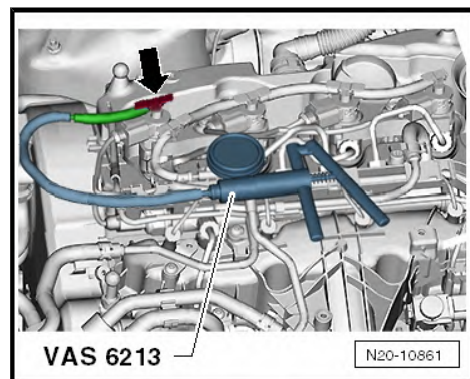

## 3.8 Removing and installing injectors

### Special tools and workshop equipment required

- ◆ Puller - T10055-

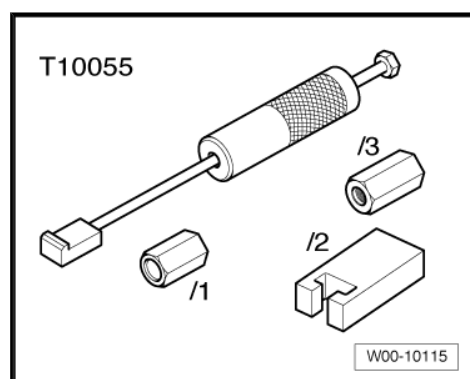

- ◆ Assembly sleeve - T10377-

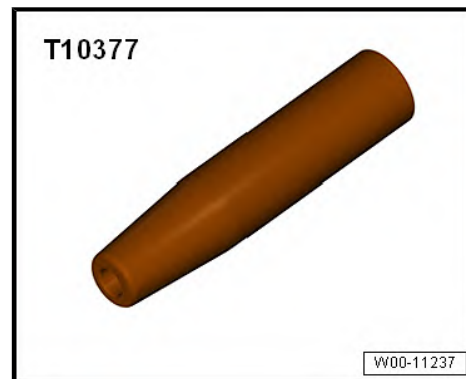

- ◆ Puller - T10537- for engine codes CXXA, CXXB

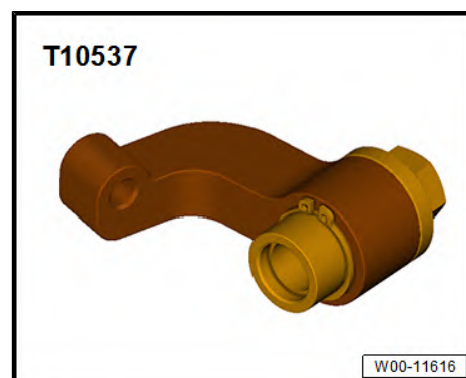

- ◆ Puller - T10415- for other engine codes

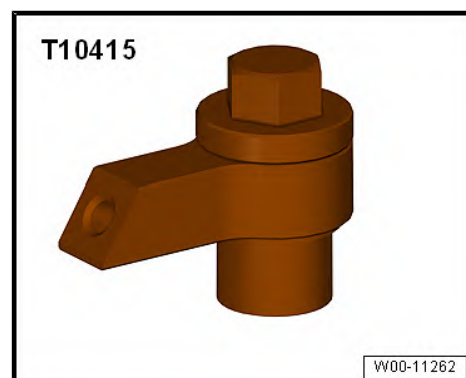

- ◆ Front-end hook - 3370- for engine codes CXXA, CXXB



### Removing

- Remove engine cover. ⇒ [page 56](#)
- Remove the sound insulation.



**Caution**

*Risk of malfunctions caused by dirt.*

◆ *Take into account: ➔ "3.1 Cleaning rules", page 13*

**Vehicles with engine codes CXXA, CXXB**

- Suspend the hook for front end - 3370- into the lower recess -arrow-.
- Unlock the middle section of the connections of the return line in -direction of arrow-.

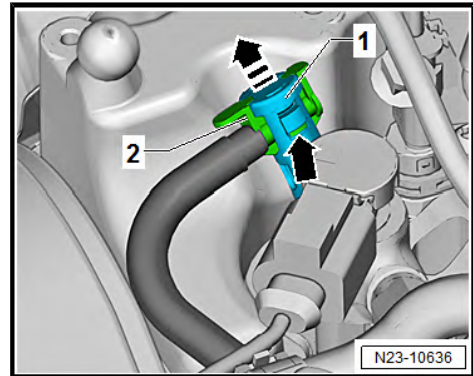

**Vehicles with other engine codes**

- Pull release tabs upwards -arrows- and pull return line connections off injectors.

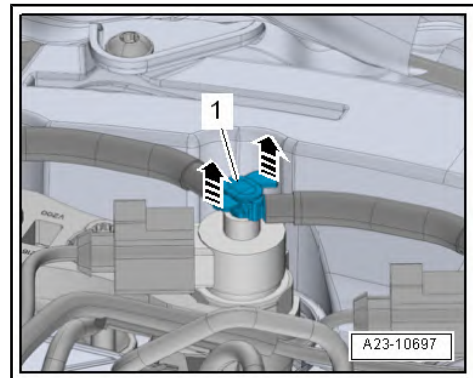

**All vehicles (continued):**

- Unplug electrical connectors -arrows- at injectors.



**Note**

*One clamping piece always secures two injectors and can only be removed if both injectors are »pulled«.*

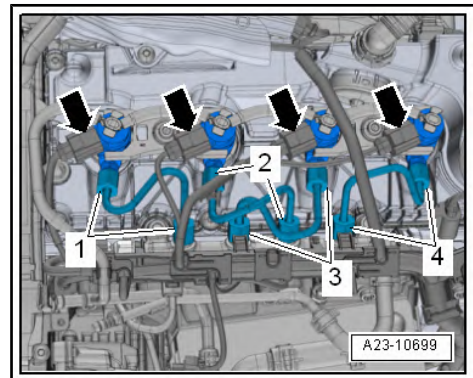

**Caution**

*When releasing high-pressure line, counterhold high-pressure connection using an open-ended spanner. Leaks occur if high-pressure connection is released.*

- Unscrew union nuts on corresponding high-pressure lines (-1 ... 4-) and remove corresponding high-pressure lines.
- Seal off open lines and connections with clean plugs.
- Correct sequence when removing injectors: First the injector on cylinder "2", then on cylinder "1" or cylinder "4" and then on cylinder "3".

**Vehicles with engine codes CXXA, CXXB**

- Apply puller - T10055- with puller - T10537- as shown in illustration, and pull out injectors upwards.

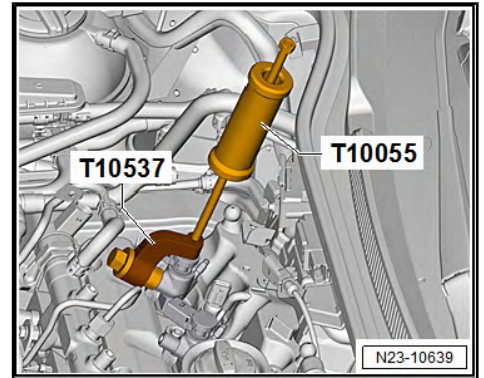

### Vehicles with all other engine codes

- Unscrew the bolt -1-.
- Apply puller - T10055- with puller - T10415- as shown in illustration, and pull out injectors upwards.

### All vehicles (continued):

- Remove clamping piece before removing injectors.



### Note

*To avoid damaging the sealing lip, rotate the injector while pulling it out.*

- Place removed injectors on a clean cloth.

### Installation



### Caution

***Risk of damage to injector sealing surface.***

- ◆ ***To remove carbon deposits from the injector sealing surface, clean the injector shaft in the cylinder head with cleaning set - VAS 6811- . Refer to ⇒ operating manual for information on how to use it.***

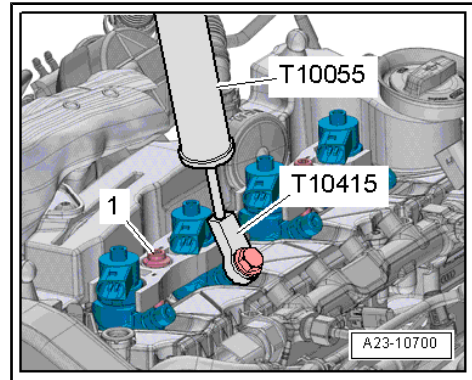

### Installing new injectors

When installing new injectors, the following components must be renewed:

- ◆ Copper seal
- ◆ Renew O-ring for injector bore.
- ◆ O-ring for fuel return line connection
- Observe all instructions for installing high-pressure pipes  
⇒ [page 313](#) .

### Installing used injectors

When re-installing used injectors, the following components must be renewed:

- ◆ Copper seal
- ◆ Renew O-ring for injector bore.
- ◆ O-ring for fuel return line connection
- Spray tip of injector with a rust removal spray. Wait approx. 5 minutes and wipe off soot particles and oil with a cloth.
- To remove the old copper seal from the injector, carefully clamp the seal in a vice until rotation of the copper seal is just prevented by the pressure between the jaws. Then carefully pull and twist the injector out of the copper seal by hand.
- Remove deposits under copper seal.

- Renew seal for injector using assembly sleeve - T10377 - .

**Continued (same procedure for used and new injectors):**

- Coat injector O-rings with assembly oil, engine oil or diesel fuel.
- Install injectors.
- Tighten union nuts on high-pressure pipes hand-tight initially. Make sure that connections are not under tension.
- When one or more injectors have been renewed, the adaption of the correction values for the new injectors must be written into the engine control unit ⇒ [page 300](#) .
- Fill/bleed fuel system ⇒ [page 293](#) .
- Install engine cover panel ⇒ [page 56](#) .

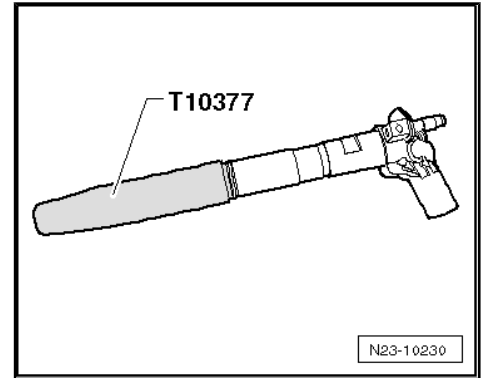

**Specified torques**

- ◆ ⇒ [“3.1 Assembly overview - injectors”, page 297](#)

### 3.9 Removing and installing high-pressure pipes

⇒ [“3.9.1 Removing high-pressure pipe between high-pressure reservoir \(rail\) and high-pressure pump”, page 313](#)

⇒ [“3.9.2 Installing high-pressure pipe”, page 313](#)

#### 3.9.1 Removing high-pressure pipe between high-pressure reservoir (rail) and high-pressure pump

**Removal**

- Remove engine cover. ⇒ [page 56](#)
- Clean fuel line and head of line using cold cleaning solvent and dry using compressed air.
- Unscrew the bolt -1-.
- Unscrew union nuts -arrows- and detach high-pressure pipe.

 **Caution**

*Risk of malfunctions caused by dirt.*

◆ **Take into account:** ⇒ [“3.1 Cleaning rules”, page 13](#)

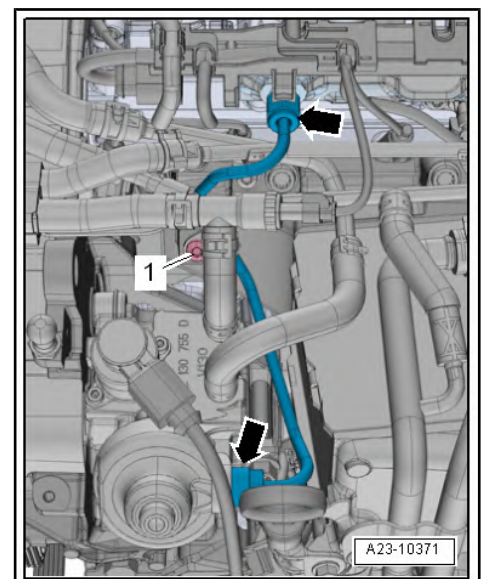

#### 3.9.2 Installing high-pressure pipe

Special tools and workshop equipment required

- ◆ Torque wrench - V.A.G 1331-

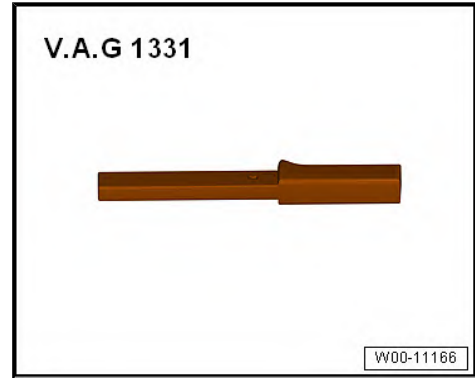

- ◆ 17 mm tool insert - V.A.G 1331/6-



- ◆ Socket - T40055-

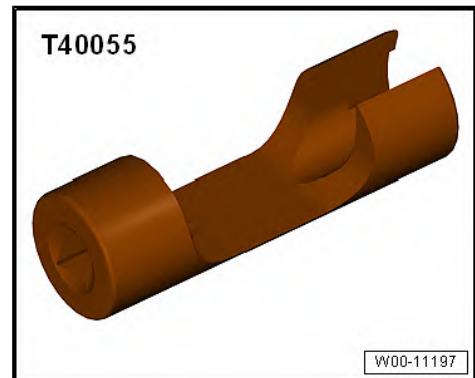

## Operation process



### Note

- ◆ *Clean fuel line and head of line using cold cleaning solvent and dry it using compressed air prior to removing.*
- ◆ *Observe cylinder specific markings when reusing high-pressure lines.*
- ◆ *The high-pressure pipes can be re-used after performing the following checks:*
- ◆ *Check taper seat of respective high-pressure line for deformation and cracks.*
- ◆ *The line hole must not be deformed, constricted or damaged.*
- ◆ *Corroded pipes must not be used again.*



**Caution**

*Risk of malfunctions caused by dirt.*

- ◆ **Take into account:** ⇒ [“3.1 Cleaning rules”, page 13](#)

*Risk of high-pressure pipe breaking if it is under tension.*

- ◆ **To ensure the injector lines are fitted free of stress, loosen high-pressure accumulator and, if necessary, move it slightly. Never bend the pipes or subject them to tension.**

- Use a vacuum-type cleaner to remove dirt from taper seat on high-pressure accumulator.
- Hand-tighten union nuts on high-pressure pipes (ensure that pipes are not under tension).
- To tighten high pressure lines on the high-pressure reservoir and on injectors, use torque wrench - V.A.G 1331- with socket wrench attachment, 17 mm - V.A.G 1331/6- or socket wrench attachment - T40055- .
- Attach vibration damper to the high-pressure line as shown ⇒ [page 315](#)

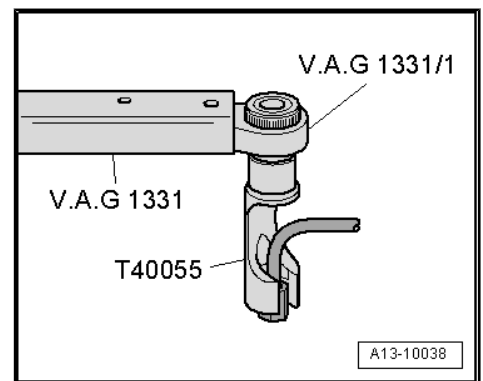

**Positioning of the vibration dampers**

- Check fuel system for leaks ⇒ [page 294](#) .
- Install engine cover panel ⇒ [page 56](#) .

**Specified torques**

- ◆ ⇒ [“3.1 Assembly overview - injectors”, page 297](#)
- ◆ ⇒ [“3.2 Exploded view - high-pressure reservoir \(rail\)”, page 299](#)

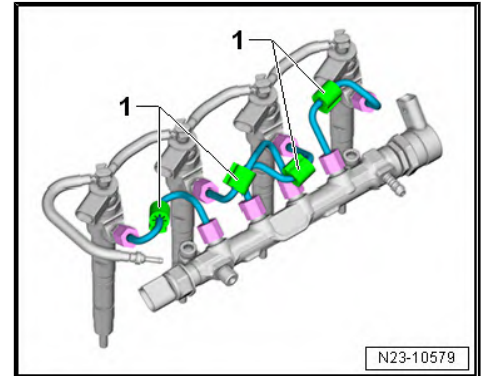

### 3.10 Removing and installing high-pressure reservoir (rail)

**Removal**



**Caution**

*Risk of malfunctions caused by dirt.*

- ◆ **Take into account:** ⇒ [“3.1 Cleaning rules”, page 13](#) .

- Remove high-pressure pipe between high-pressure reservoir (rail) and high-pressure pump ⇒ [page 313](#) .

- Release and pull off connector -1- on fuel temperature sender - G81- .

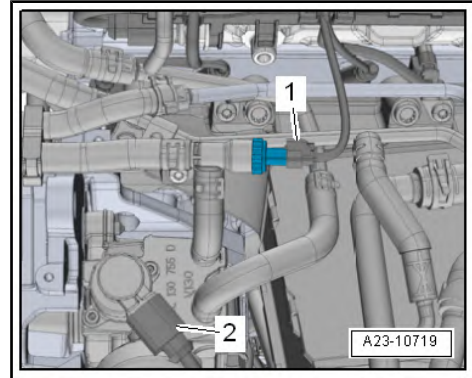

- Release and pull off connector -2- on fuel pressure regulating valve - N276- .

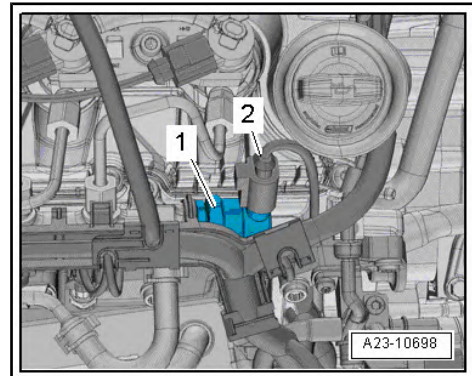

- Release and pull off connector -arrow- on fuel pressure sender - G247- .

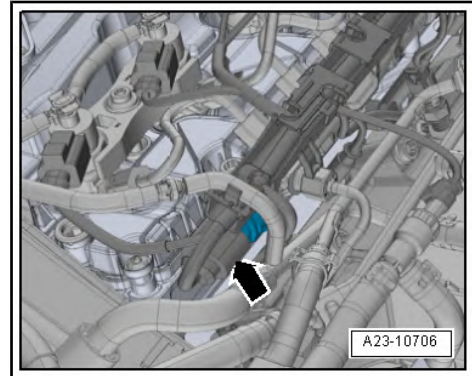

- Release and pull off connector -1- on charge air temperature sender after charge air cooler - G811- .

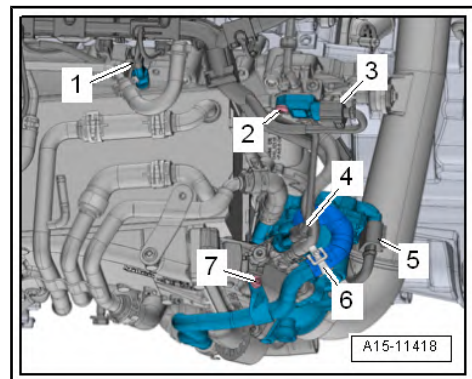

- Release and pull off connector -3- for coolant pump.

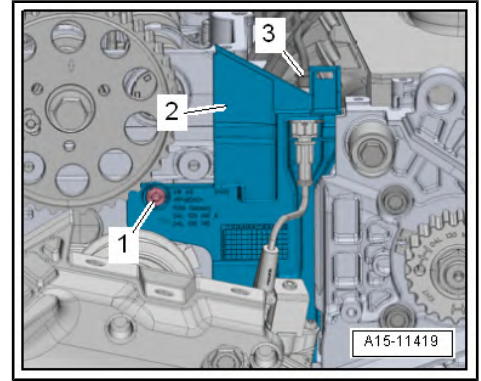

- Open heat insulation sleeve -1-.
- Release and pull off the electrical connectors -3, 5 and 6-.

**i** Note

*-Ignore positions 2 and 4-.*

- Move clear electrical wiring harness.

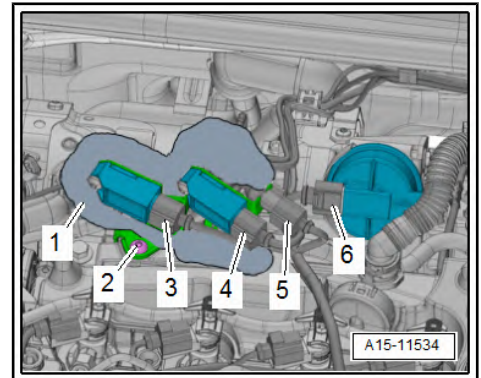

- Unscrew bolts -arrows-, and pull back lines.
- Release and pull off connector -2- on Hall sender - G40- .

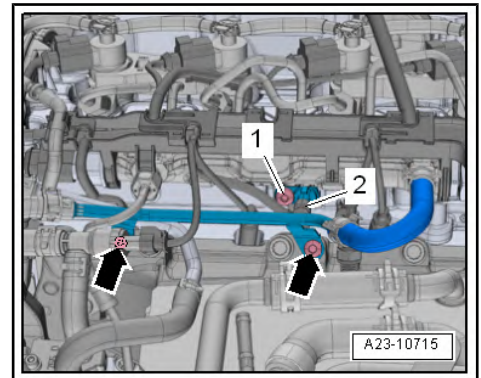

- Release and pull off connectors -arrows- on injectors.

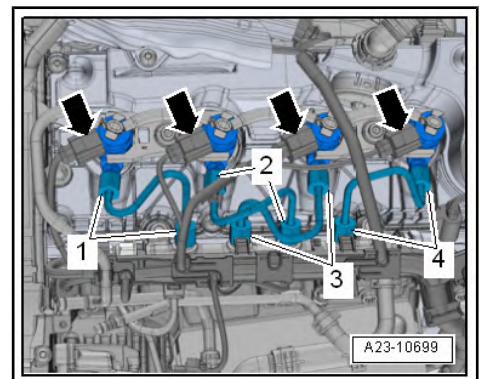

- Disconnect connectors on glow plugs.

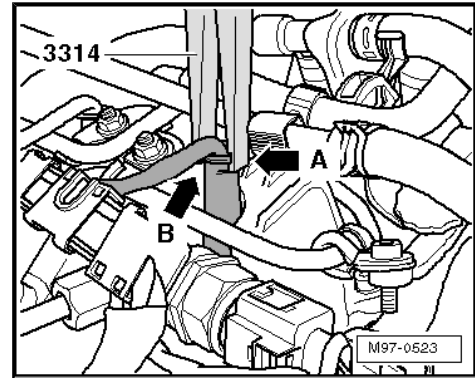

- Move clear fuel return hose -1-.
- Open retaining clips -arrows-, and unclip and detach wiring duct -2-.

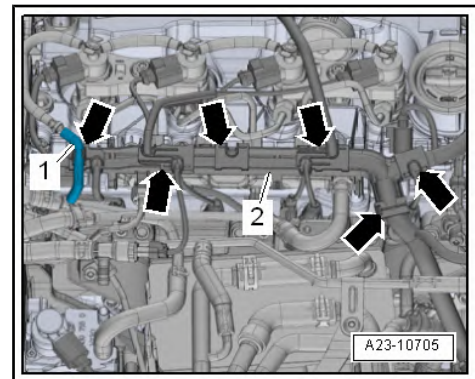

- Unplug electrical connectors:
  - 1 - For fuel pressure sender - G247-
  - 3 - For fuel pressure regulating valve - N276-
- Loosen the hose clip -4-, remove the fuel return hose.
- Remove union nuts -2- for high-pressure pipes.
- Detach high-pressure pipe and set it down on a clean cloth.
- Remove bolts -arrows- and detach high-pressure reservoir.

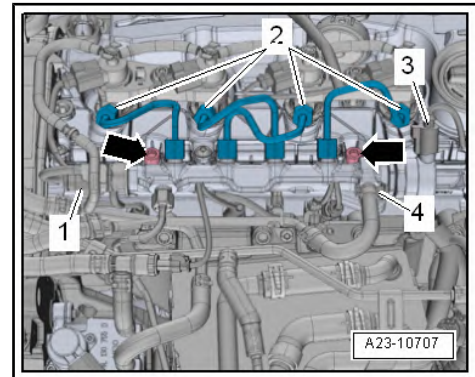

### Installation

Installation is carried out in the reverse order; note the following:

- Observe all instructions for installing high-pressure pipes  
⇒ [page 313](#) .

### Specified torques

- ◆ ⇒ [“3.1 Assembly overview - injectors”, page 297](#)
- ◆ ⇒ [“3.2 Exploded view - high-pressure reservoir \(rail\)”, page 299](#)

## 4 Air cleaner

⇒ [“4.1 Exploded view - air cleaner housing”, page 319](#)

⇒ [“4.2 Air filter housing: removing and fitting”, page 320](#)

### 4.1 Exploded view - air cleaner housing

#### 1 - Air deflector

- On air cleaner (bottom section)

#### 2 - Bolt.

- 2 Nm

#### 3 - Lower part of air duct

- On lock carrier

#### 4 - Upper part for air duct

- On lock carrier

#### 5 - Cover

- for air duct

#### 6 - Bolt.

- 2 Nm

#### 7 - Bolt.

- 1.5 Nm

#### 8 - Air filter top section

- Clean out dirt, leaves and salt deposits

#### 9 - Breather hose

- From charge pressure control solenoid valve - N75-

#### 10 - Spring type clip

#### 11 - Air intake hose

#### 12 - Screw-type clip

- Installation ⇒ [page 320](#)

#### 13 - Bolt.

- 1.5 Nm

#### 14 - Air mass gauge - G70-

- Removing and fitting ⇒ [page 339](#)

#### 15 - O-ring

- Renew if damaged.

#### 16 - Air filter element

- Use genuine air filter element ⇒ Electronic parts catalogue
- Change interval ⇒ Maintenance tables
- Removing and installing ⇒ Maintenance ; Booklet 501 .

#### 17 - Battery cell

- For lower part of air filter

#### 18 - Air cleaner (bottom section)

- Clean out dirt, leaves and salt deposits

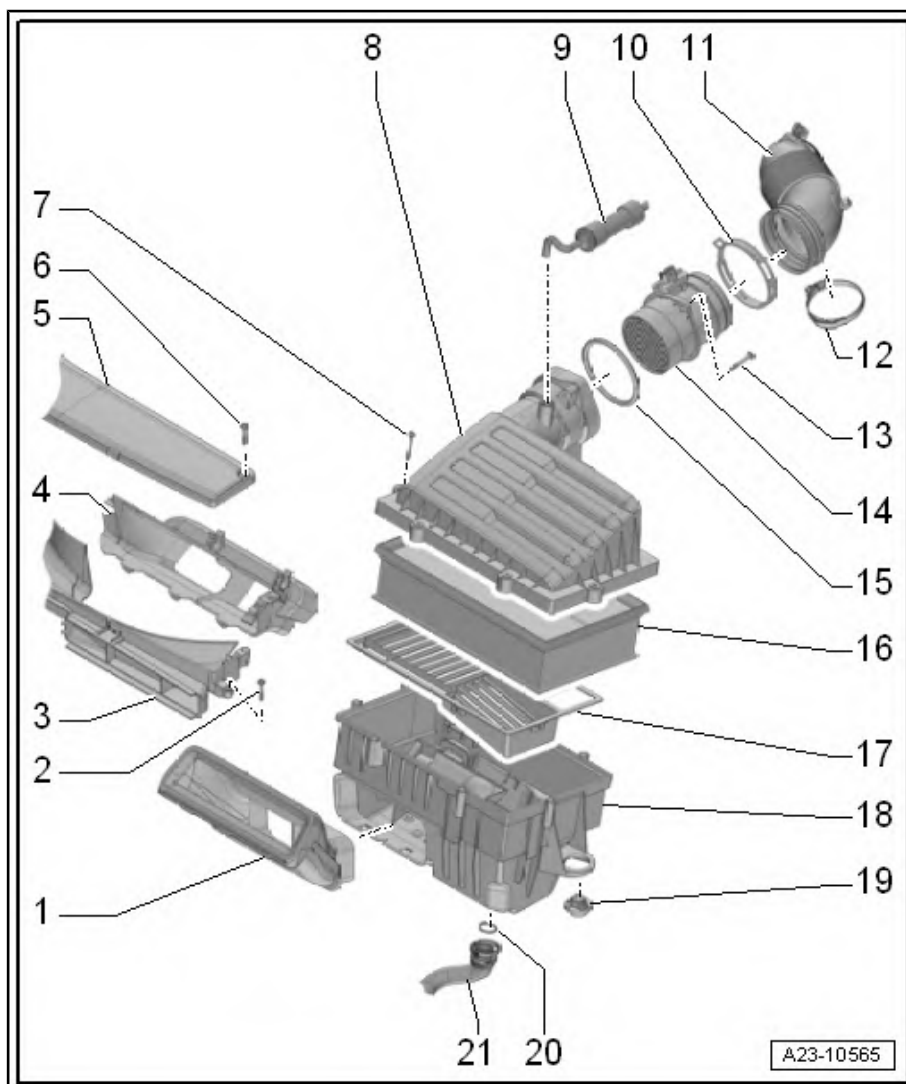

### 19 - Rubber buffer

### 20 - O-ring

- Renew if damaged.

### 21 - Water drain hose

- With valve
- clean

### Install air ducts with screw-type clips



#### Note

- ◆ *Hose unions and air intake pipes/hoses must be free of oil and grease when installing.*
- ◆ *Secure all hose connections with the correct type of hose clips (same as original equipment) ⇒ Electronic parts catalogue .*
- ◆ *To ensure that the air hoses can be properly secured at their connections, spray rust remover onto the worm thread of used hose clips before installing.*

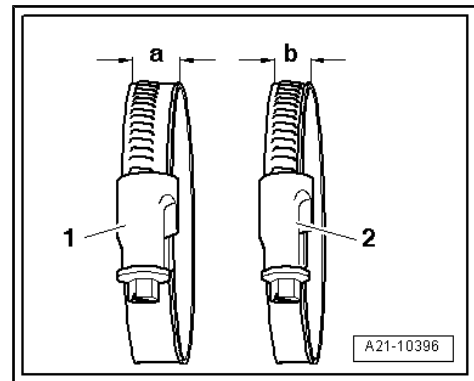

#### Tightening torque for

- 1 - Hose clip -a- = 13 mm wide: 5.5 Nm
- 2 - Hose clip -b- = 9 mm wide: 3 Nm

## 4.2 Air filter housing: removing and fitting

### Special tools and workshop equipment required

- ◆ Hose clip pliers - VAS 6362-



### Removal

Remove air cleaner housing ⇒ [page 321](#) .

For reasons of space, remove the air filter housing together with the intake hose ⇒ [page 321](#) .

### Remove air filter housing.

- Unplug electrical connector -2- for air mass meter - G70- .
- Disconnect vacuum hose -4-.
- Loosen the hose clip -3-, remove the air intake hose.
- Pull up the air filter cleaning -1- and remove from both of the retaining pins -5- of the battery tray.

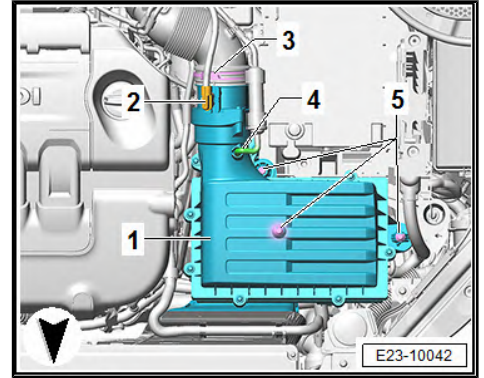

- Remove air filter housing -3- in -direction of arrow-. To do this, separate air pipe -2- from upper part of the air duct -1-.

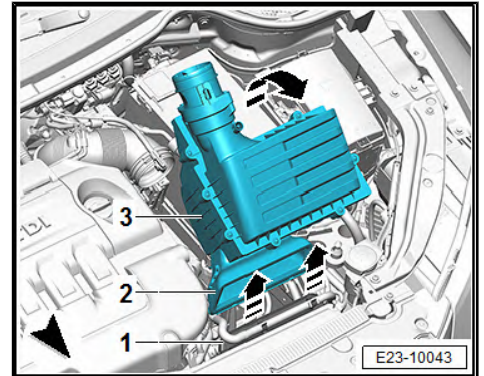

### For reasons of space, remove air filter housing together with air intake hose.

- Unplug electrical connector -2- for air mass meter - G70- .
- Free vacuum hose -arrows- at air intake hose.
- Disconnect vacuum hose -4-.
- Loosen hose clip -3- and detach air intake hose from connection.
- Pull up the air filter cleaning -1- and remove from both of the retaining pins -5- of the battery tray.

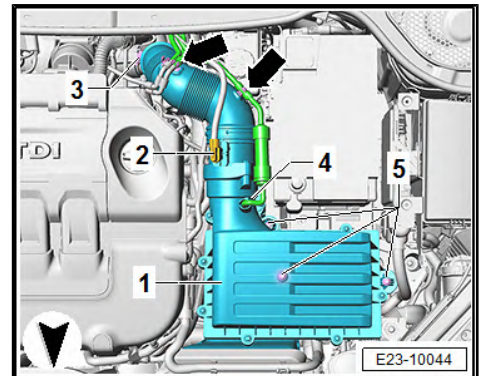

- Remove air filter housing -3- in -direction of arrow-. To do this, separate air pipe -2- from upper part of the air duct -1-.

### Installation

Installation is carried out in the reverse order; note the following:

- Tightening torque  
⇒ ["4.1 Exploded view - air cleaner housing", page 319](#)



#### Note

- ◆ *Hose unions and air intake pipes/hoses must be free of oil and grease when installing.*
- ◆ *Use a silicone-free lubricant when installing the air hose.*
- ◆ *Secure all hose connections with the correct type of hose clips (same as original equipment) ⇒ Electronic parts catalogue .*

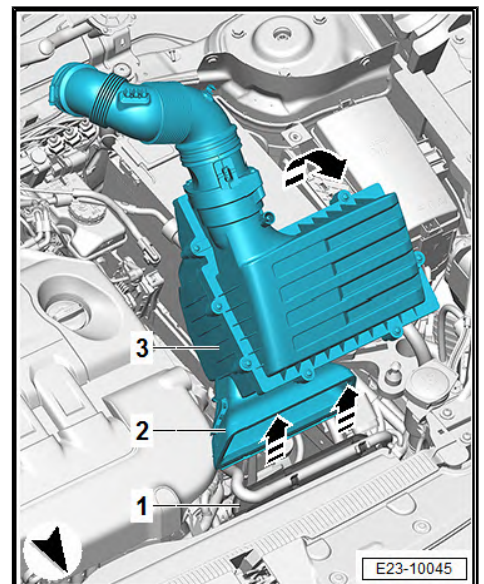

- Disconnect water drain hose -arrow-.
- Clean dirt and leaves out of connection on air cleaner (bottom section) and hose.

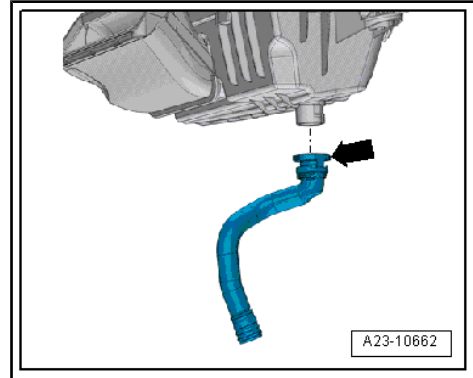

- When fitting intake connecting pipe on air cleaner housing, pay attention to installation markings -arrows-.
- Fit air cleaner housing on battery tray and press on so that it engages audibly.
- Press air cleaner housing on again and then pull to check that housing is correctly engaged.

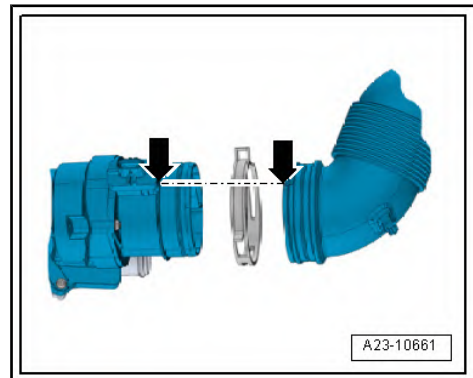

## 5 Suction pipe

⇒ ["5.1 Exploded view - intake manifold", page 323](#)

⇒ ["5.2 Removing and installing intake manifold", page 325](#)

⇒ ["5.3 Throttle valve control unit J338 : removing and fitting", page 328](#)

### 5.1 Exploded view - intake manifold

#### 1 - Oil seal

- Renew following removal

#### 2 - Dowel pin

#### 3 - Bolt.

- 8 Nm

#### 4 - Seal

- Renew following removal

#### 5 - Bolt.

- Tightening torque and sequence ⇒ [page 325](#) .

#### 6 - Bracket/bearing/support

- For intake manifold.

#### 7 - Bolt.

- Tightening torque and sequence ⇒ [page 325](#) .

#### 8 - Bolt.

- Renew following removal
- Tightening torque and sequence ⇒ [page 324](#) .

#### 9 - Dowel pin

#### 10 - Bolt.

- 8 Nm

#### 11 - Intake manifold with charge air cooler

- Intake manifold and charge air cooler are combined as one unit

- Removing and fitting ⇒ [page 325](#)

#### 12 - Bolt.

- Renew following removal
- Tightening torque and sequence ⇒ [page 324](#) .

#### 13 - Charge air temperature sender after charge air cooler - G811-

- Removing and fitting ⇒ [page 347](#)
- 22 Nm

#### 14 - Seal

- Renew following removal

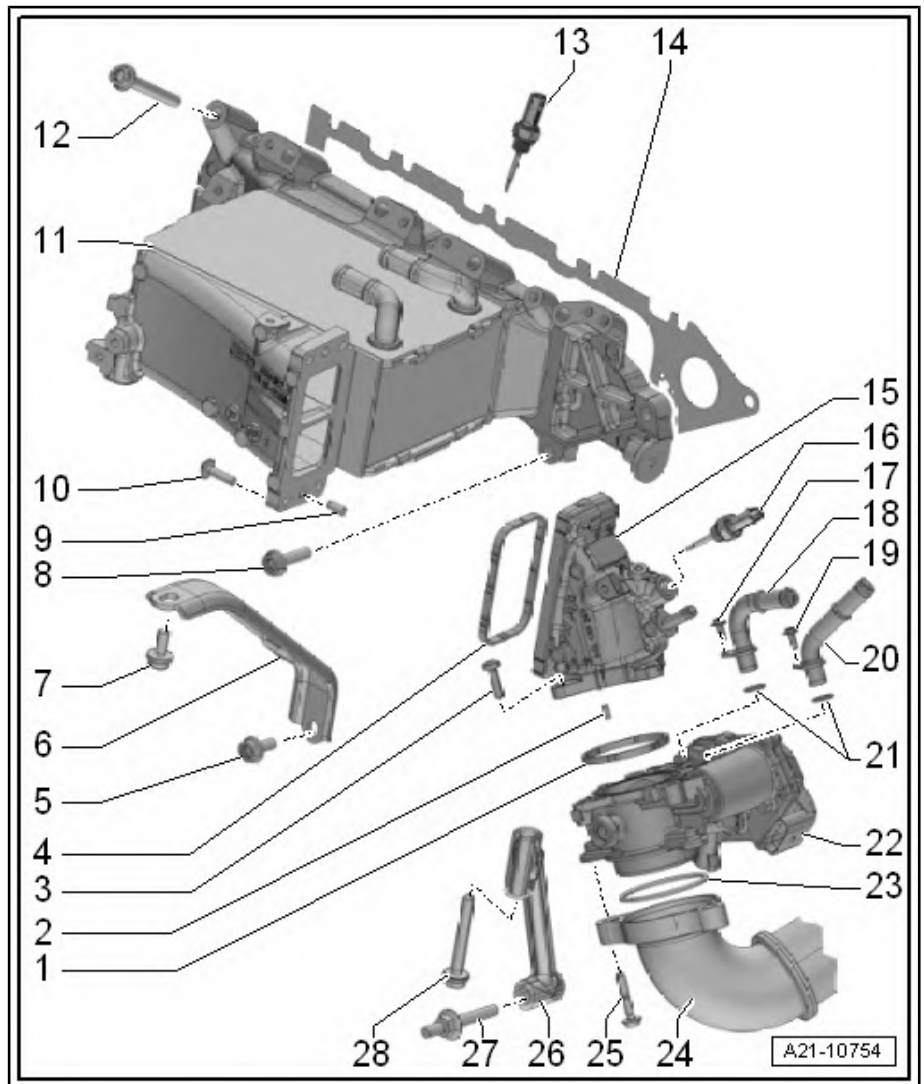

### 15 - Connection

- for throttle valve control unit - J338-

### 16 - Charge air temperature sender before charge air cooler - G810-

- Removing and fitting ⇒ [page 347](#)
- 22 Nm

### 17 - Bolt.

- 10 Nm

### 18 - Coolant pipe

### 19 - Bolt.

- 10 Nm

### 20 - Coolant pipe

### 21 - O-rings

- Renew following removal

### 22 - Throttle valve control mechanism - J338-

- With throttle valve potentiometer - G69-
- Removing and fitting ⇒ [page 328](#)

### 23 - O-ring

- Renew following removal

### 24 - Air intake pipe

### 25 - Bolt.

Tightening torque ⇒ [page 252](#)

### 26 - Bracket/bearing/support

- for throttle valve control unit - J338-

### 27 - Bolt.

- Air pipe ⇒ [page 325](#)

### 28 - Bolt.

- Air pipe ⇒ [page 325](#)

### Intake manifold with charge air cooler - tightening torque and sequence

– Tighten bolts in stages:

stage	Bolts	Tightening torque
1st	-1 ... 10-	Screw in by hand until they make contact
2nd	-1 ... 10-	Tighten to 20 Nm
3.	-1 ... 10-	turn 90° further

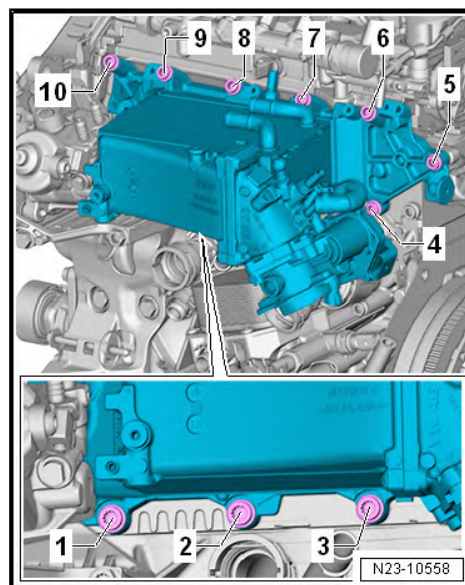

**Bracket for intake manifold and bracket for throttle valve module  
- tightening torque and sequence**

- Tighten bolts in stages:



**Caution**

*When installing the brackets for intake manifold and throttle valve module always ensure they are free of stress and not installed at an angle.*

stage	Bolt/nut	Tightening torque
1st	-2, 3, 4, 7-	Screw in as far as stop and tighten by hand.
2nd	-2, 3, 4, 7-	Tighten to 20 Nm
3.	-5-	Tighten to 10 Nm
4.	-1-	Tighten to 10 Nm

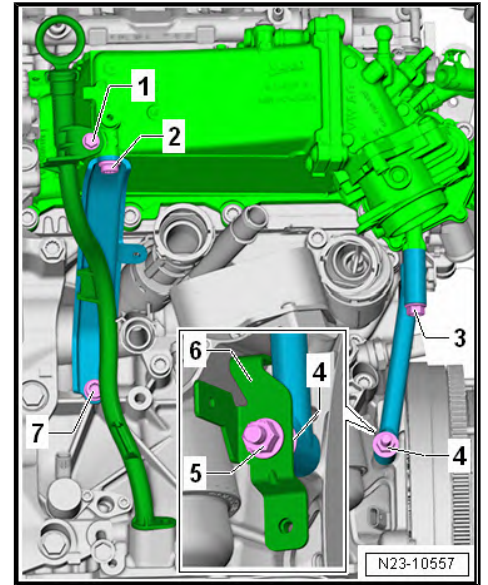

**5.2 Removing and installing intake manifold**



**Note**

*Intake manifold and charge air cooler are combined as one unit.*

**Special tools and workshop equipment required**

- ◆ Hose clip pliers - VAS 6362-

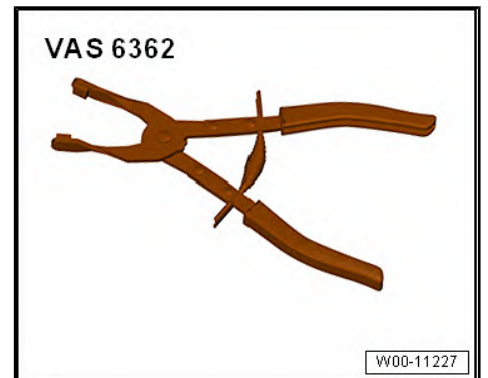

- ◆ Socket insert XZN 10 - T10501-



- ◆ Protective mat - VAS 531003-

**Removal**

- Remove coolant pipes (top front) ⇒ [page 209](#) .

- Remove high-pressure pipe ➔ [page 313](#) .
- Unscrew screws -arrows- using wrench XZN 10 - T10501- .
- Release screw-type clip -2- and detach air pipe -1-.

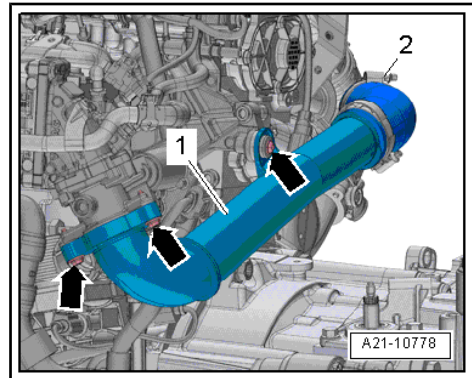

- Unplug the electrical connector -4-.



**Caution**

*Risk of malfunctions caused by dirt.*

◆ *Take into account: ➔ "3.1 Cleaning rules", page 13*

- Loosen the hose clips -1, 2-, remove the fuel hoses.
- Remove bolts -3- and move fuel lines to rear.
- Release the fastener -arrow-, remove the vacuum hose -1-.
- Remove bolt -3-; disconnect the vacuum hose -2-

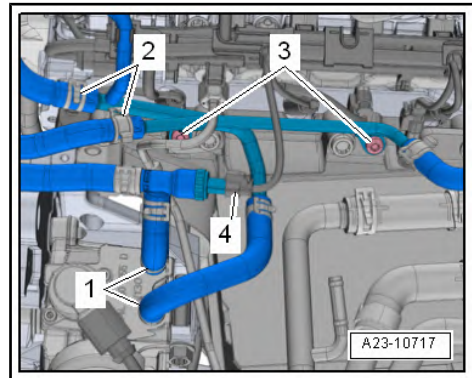

**Note**

*The installation position of the components depends upon the version.*

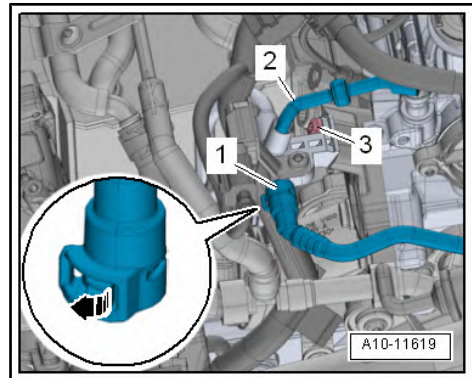

**Vehicles with variable valve timing:**

- Unplug the electrical connector -1-.
- Loosen the clamp -2-.

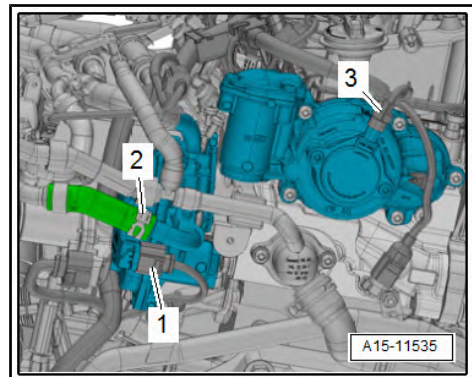

**All vehicles (continued):**

- Unplug electrical connectors and move clear:
- 1 - For charge air temperature sender after charge air cooler - G811-
- 3 - For charge pressure sender - G31-
- 4 - For intake air temperature sender - G42-
- 5 - for throttle valve control unit - J338-
- Unscrew and remove the bolts -2, 7-, remove the coolant hose -6-.
- Remove radiator cowl ⇒ [page 244](#) .

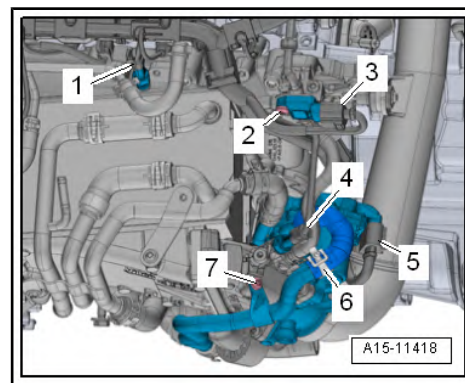

- Install protective mat - VAS 531003- to vehicle as shown in illustration.

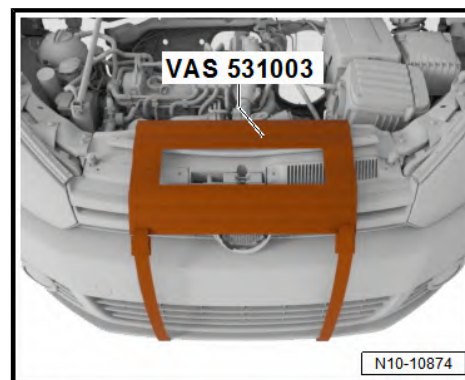

**Vehicles with exhaust gas recirculation control motor - V338- :**

- Remove throttle valve control unit - J338- ⇒ [page 328](#)

- Remove bolt -1- for dipstick guide tube.
- Remove nut -5- and detach bracket -6- from centre hex stud -4-.
- Loosen bolts -4 and 7-.
- Remove bolts -2, 3- for bracket for intake manifold.

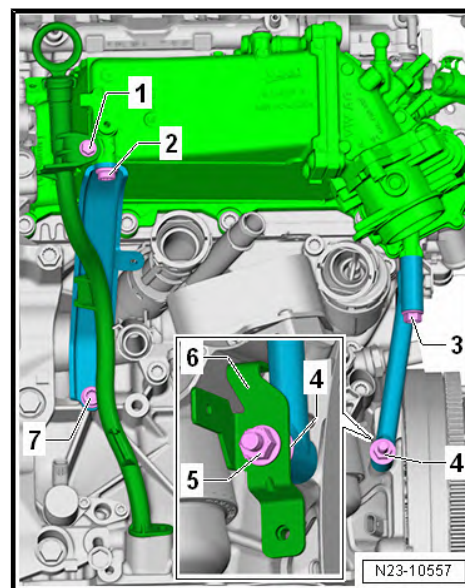

- Unscrew the screws -10 ... 1- with the socket insert XZN 10 - T10501- and remove the suction pipe with charge-air cooler.

### Installation

- Fit new gasket onto dowel pins on cylinder head.



### Caution

*Do not damage sealing surface of intake manifold by guiding it against dowel pins.*

- Fit intake manifold onto dowel pins on cylinder head.

- Tighten the screws 1 ... 10; tightening torque and sequence in accordance with specifications.

Remaining installation sequence carried out in reverse sequence; note the following:



### Note

*Seal must be renewed if removed*

- Install the air cleaner housing ⇒ [page 320](#) .
- Install high-pressure pipe ⇒ [page 313](#) .
- Install coolant pipes (top front) ⇒ [page 208](#) .

### Specified torques

- ◆ Intake manifold with charge air cooler - tightening torque and sequence ⇒ [page 324](#)
- ◆ Install air ducts with screw-type clips ⇒ [page 320](#)
- ◆ ⇒ ["5.1 Exploded view - intake manifold", page 323](#)
- ◆ ⇒ ["1.1 Exploded view - sump/oil pump", page 159](#)

## 5.3 Throttle valve control unit - J338- : removing and fitting

### Special tools and workshop equipment required

- ◆ Hose clamps, up to 25 mm - 3094-

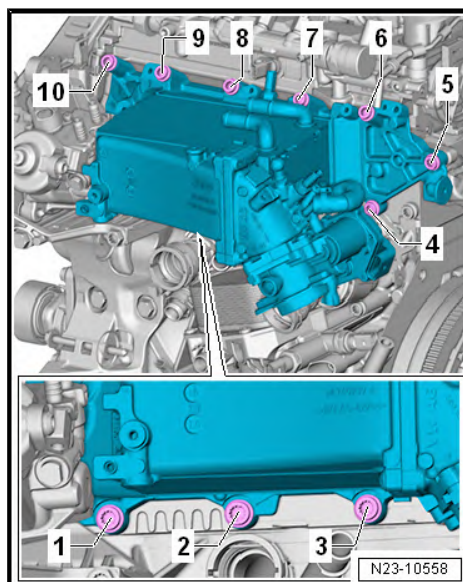
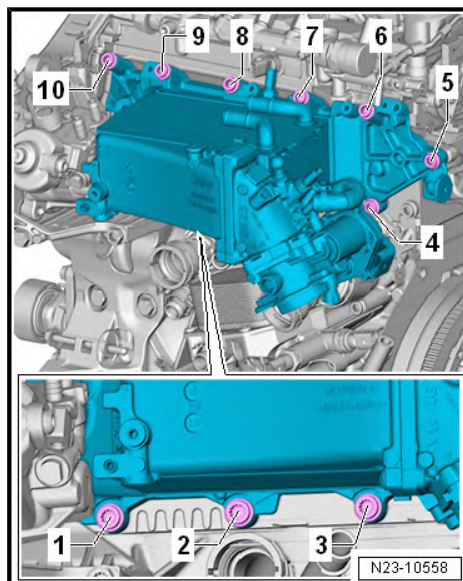

- ◆ Hose clip pliers - VAS 6362-



### Removal

- Remove engine cover. ⇒ [page 56](#)
- For reasons of space, remove the air filter housing together with the intake hose ⇒ [page 321](#) .
- Free coolant hose -3-.
- Remove screws -1-.
- Release locking lugs-arrow-, unclip air hose -2- from the front end and remove in -direction of the arrow-.

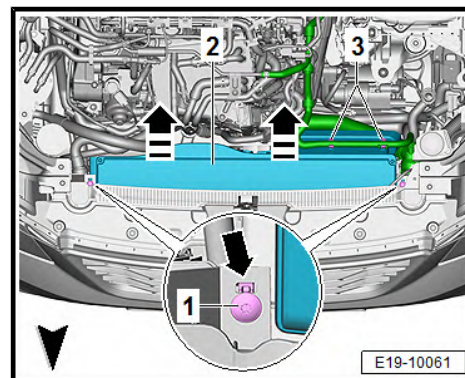

- Remove bolts -arrows-.
- Release screw-type clip -2- and detach air pipe -1-.

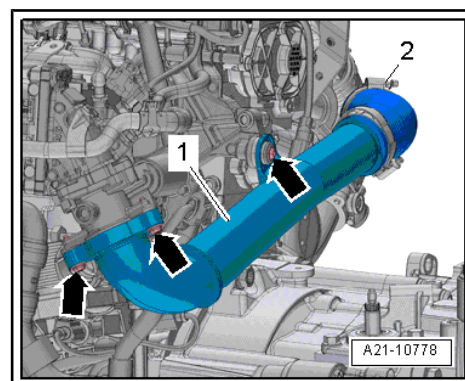

- Remove bolts -arrows-.
- Clamp off coolant hoses -1- and -5- using hose clamps for hoses up to 25 mm - 3094- .

### Note

- ◆ Place a cloth underneath to catch escaping coolant.
- ◆ Depending on the version, the number of connected coolant hoses may be different.
- Loosen the hose clips -2, 3, 4- and remove the coolant hoses.

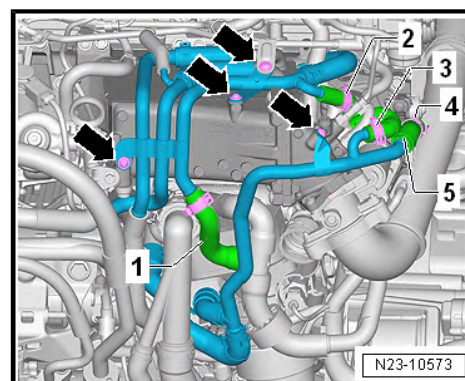

- Unscrew the bolt -3-.



**Note**

*Ignore -items 1 and 2-.*

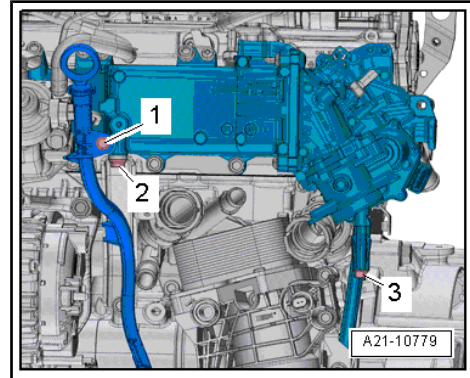

- Disconnect plug-in connectors:
  - 2 - For intake air temperature sender - G42-
  - 3 - for throttle valve control unit - J338-
- Loosen the hose clip -4-, remove the air intake hose.
- Remove bolts -1- and detach connection with throttle valve module - J338- .

**Installation**

Installation is carried out in the reverse order; note the following:

- Tightening torque  
⇒ ["5.1 Exploded view - intake manifold", page 323](#)

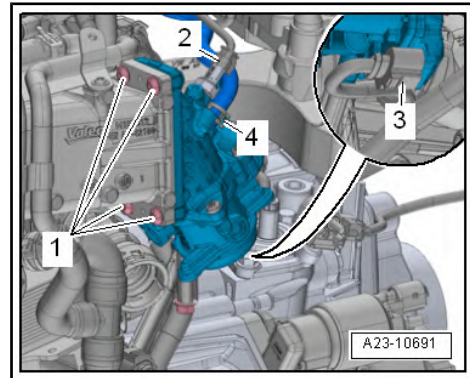

**Note**

*Renew seals and O-ring after each removal.*

- When fitting intake connecting pipe with throttle valve module - J338- , pay attention to dowel pins.
- Install coolant pipes (top front) ⇒ [page 208](#) .
- Install the air cleaner housing ⇒ [page 320](#) .
- Install engine cover panel ⇒ [page 56](#) .

**Specified torques**

- ◆ ⇒ ["4.1 Exploded view - air cleaner housing", page 319](#)

## 6 Sensors

⇒ [“6.1 Remove and install fuel pressure regulating valve N276 ”, page 331](#)

⇒ [“6.2 Checking fuel pressure regulating valve N276 ”, page 337](#)

⇒ [“6.3 Removing and installing fuel pressure sensor G247 ”, page 338](#)

⇒ [“6.4 Air mass meter G70 / intake air temperature sender G42 : Removal and installation”, page 339](#)

⇒ [“6.5 Removing and installing differential pressure sensor G505 ”, page 341](#)

⇒ [“6.6 Removing and installing exhaust gas pressure sensor 1 G450 ”, page 345](#)

⇒ [“6.7 Removing and installing charge air temperature sender ahead of charge air cooler G810 ”, page 347](#)

⇒ [“6.8 Removing and installing charge air temperature sender after charge air cooler G811 ”, page 347](#)

⇒ [“6.9 Removing and installing fuel temperature sender G81 ”, page 347](#)

### 6.1 Remove and install fuel pressure regulating valve - N276-

⇒ [“6.1.1 Versions of fuel pressure regulating valve N276 ”, page 331](#)

⇒ [“6.1.2 Removing and installing fuel pressure regulating valve N276 , version 1”, page 332](#)

⇒ [“6.1.3 Removing and installing fuel pressure regulating valve N276 , version 2”, page 335](#)

#### 6.1.1 Versions of fuel pressure regulating valve - N276-

Different versions of the fuel pressure regulating valve are installed:

- Check which version is installed before removing and installing.

##### Version 1

- Removing and installing, version 1 ⇒ [page 332](#) .

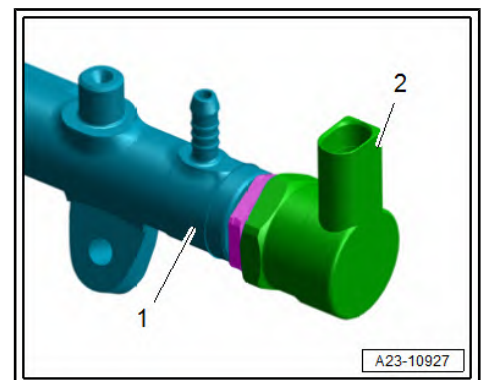

## Version 2

- Removing and installing, version 2 ⇒ [page 335](#) .

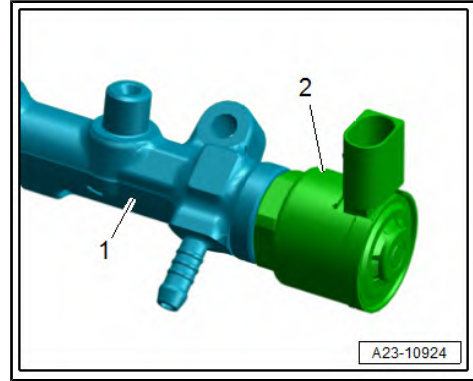

## 6.1.2 Removing and installing fuel pressure regulating valve - N276- , version 1

### Removal

- Remove engine cover. ⇒ [page 56](#)
- Release and pull off connector -1- on fuel temperature sender - G81- .
- Release and pull off connector -2- on fuel pressure regulating valve - N276- .
- Release and pull off connector -arrow- on fuel pressure sender - G247- .

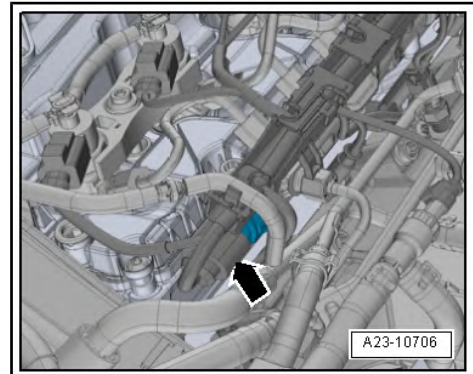
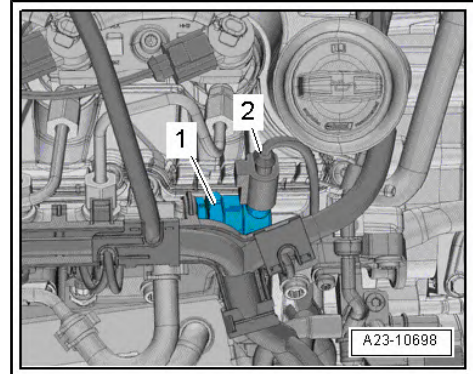
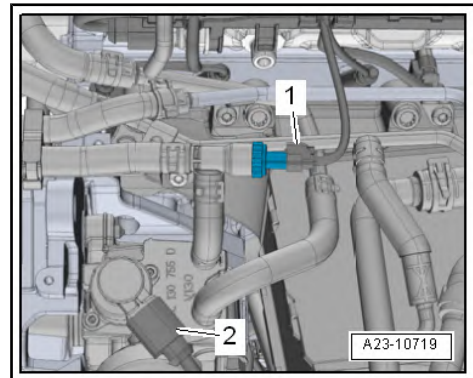

- Release and pull off connector -1- on charge air temperature sender after charge air cooler - G811- .

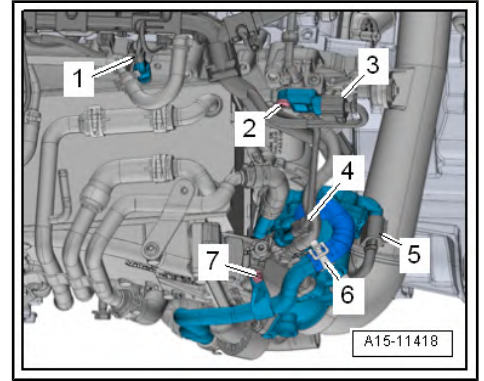

- Release and pull off connector -3- for coolant pump.

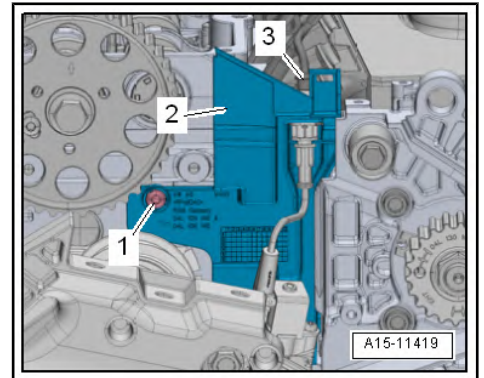

- Open heat insulation sleeve -1-.
- Release and disconnect the electrical connectors -3- and -6-.
- If fitted, release and pull off connectors -4- and -5-.
- Move clear electrical wiring harness.

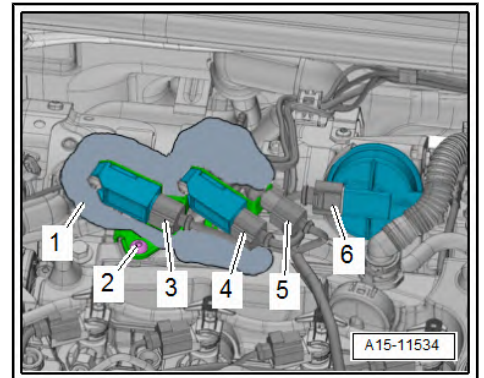

- Unscrew bolts -arrows-, and pull back lines.
- Release and pull off connector -2- on Hall sender - G40- .

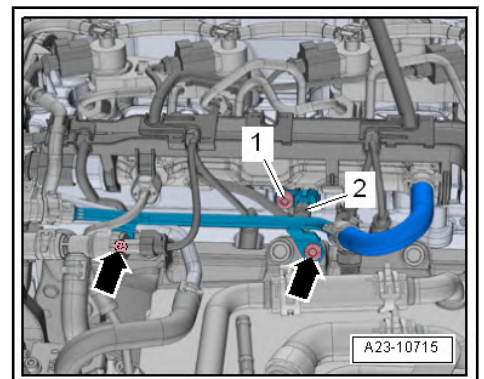

- Remove caps on injectors.
- Release and pull off connectors -arrows- on injectors.

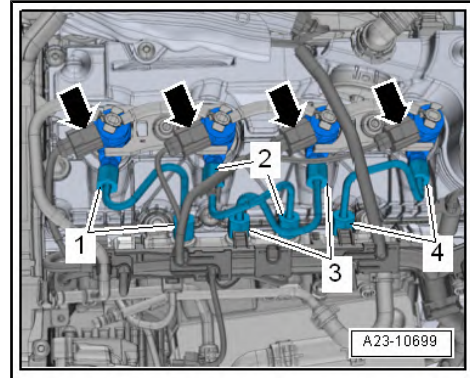

- Disconnect connectors on glow plugs.

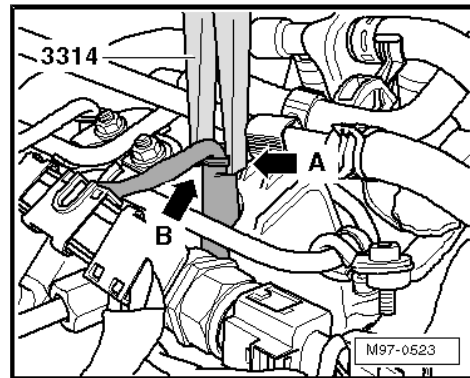

- Move clear fuel return hose -1-, and disconnect it.
- Open retaining clips -arrows-, and unclip and detach wiring duct -2-.
- Before removal, clean area around thread for fuel pressure regulating valve - N276- using e.g. commercial cleaning solution.
- Make sure no dirt gets into opening in high-pressure reservoir.
- Proceed carefully. The cleaning agent should not enter in the connection.
- Dry fuel pressure regulating valve - N276- .

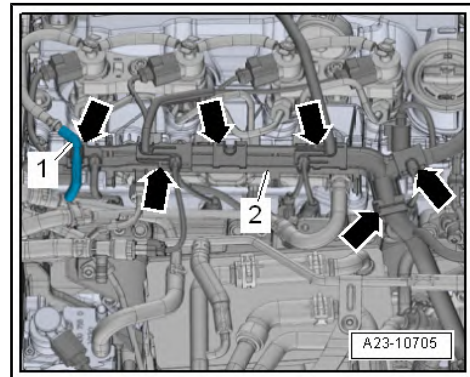

- Unplug the electrical connector -2-.
- Loosen union nut -1- (counterhold at hexagon flats on high-pressure reservoir). Then unscrew and remove by hand.
- Use suction device to extract dirt from high-pressure accumulator bore (threads and sealing surface). Do not use tools or other instruments for this purpose.
- Seal off open connection in high-pressure reservoir with clean plug.

#### Installation

- Tightening torque  
 ⇒ ["3.2 Exploded view - high-pressure reservoir \(rail\)", page 299](#)

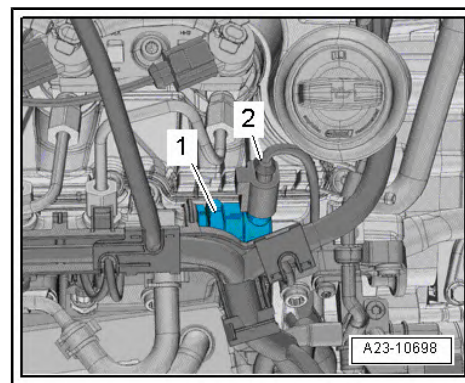

#### Note

- ◆ *Fuel pressure regulating valve - N276- must always be renewed after it has been removed.*
- ◆ *The beginning of the thread and the deformable sealing lip of the fuel pressure regulating valve - N276- must be coated with diesel fuel.*
- Tighten union nut by hand.
- Align the new regulating valve so that connecting line is free of tension after connector is attached.
- Hold regulating valve housing in this position with an open-end spanner on hexagon or use pliers (e.g. water pump pliers).
- Use a suitable torque wrench with an open-ended wrench insert (AF 30) to tighten the union nut.
- Filling, bleeding fuel system ⇒ [page 293](#)
- Install engine cover panel ⇒ [page 56](#) .
- After replacement, the learnt values must be reset ⇒ Vehicle diagnostic tester.
- ◆ Self-diagnosis-capable systems
- ◆ 0001 - Engine electronics
- ◆ 0001 - Engine electronics, functions
- ◆ 0001 - Reset adaptation values of engine ctrl. module
- ◆ Reset learnt values of the metering unit and the pressure control valve

### 6.1.3 Removing and installing fuel pressure regulating valve - N276- , version 2

Special tools and workshop equipment required

- ◆ Open end spanner insert SW 30 - T10553-



- ◆ Torque wrench - V.A.G 1332-



### Removal

- Remove engine cover. ⇒ [page 56](#)
- Release and unplug electrical connector -2-.
- Removing high-pressure accumulator (rail) ⇒ [page 315](#) .
- Do not loosen fuel pressure regulating valve - N276- -1- on fuel rail in installed condition.

### Note

*Clamp fuel rail in a vice to remove pressure regulating valve. Use protective jaw covers for the vice. Position the fuel rail in such a way that no force is exerted on the threaded connections for the high-pressure lines or the retaining tabs for securing the fuel rail to the cylinder head.*

- Clamp high-pressure accumulator in a vice with protective jaws.
- Loosen fuel pressure regulating valve - N276- -1- fuel rail.
- Before removal, clean area around thread for fuel pressure regulating valve - N276- using e.g. commercial cleaning solution.
- Make sure no dirt gets into opening in high-pressure reservoir.
- Proceed carefully. The cleaning agent should not enter in the connection.

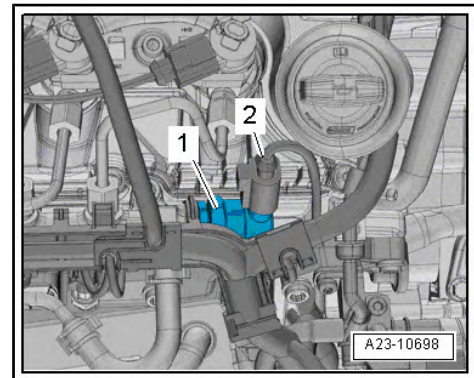

- Unbolt fuel pressure regulating valve - N276- -2- from fuel rail -1-.
- Dry fuel pressure regulating valve - N276- .
- Use suction device to extract dirt from high-pressure accumulator bore (threads and sealing surface). Do not use tools or other instruments for this purpose.
- Seal off open connection in high-pressure reservoir with clean plug.

### Installation



#### Note

- ◆ *Fuel pressure regulating valve - N276- must always be renewed after it has been removed.*
- ◆ *The beginning of the thread and the deformable sealing lip of the fuel pressure regulating valve - N276- must be coated with diesel fuel.*
- Screw in fuel pressure regulating valve - N276- , and tighten it by hand.
- Install high-pressure accumulator (rail) ⇒ [page 315](#) .
- Align fuel pressure regulating valve - N276- -1- using suitable workshop equipment.
- Turn valve in such a way that the connector can be connected to connection -2- free of tension.
- The installation position of connection -2- may differ.
- Filling, bleeding fuel system ⇒ [page 293](#)
- Install engine cover panel ⇒ [page 56](#) .

### Specified torques

- ◆ ⇒ [“3.2 Exploded view - high-pressure reservoir \(rail\)”, page 299](#)

## 6.2 Checking fuel pressure regulating valve - N276-

### Special tools and workshop equipment required

- ◆ Measuring container, fuel-resistant

### Operation process

- Remove engine cover. ⇒ [page 56](#)
- Loosen the hose clip -arrow-, remove the fuel return hose from the high-pressure reservoir.
- Seal off open return line connection with a plug.



#### Caution

*Risk of malfunctions caused by dirt.*

- ◆ *Take into account: ⇒ [“3.1 Cleaning rules”, page 13](#)*

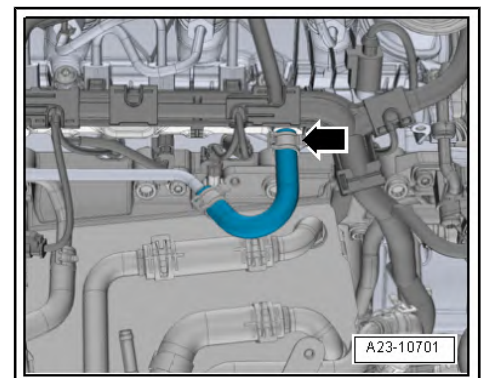
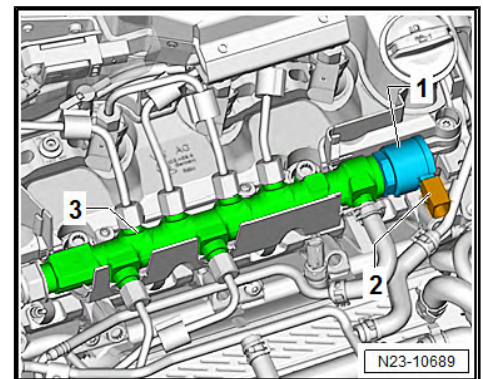
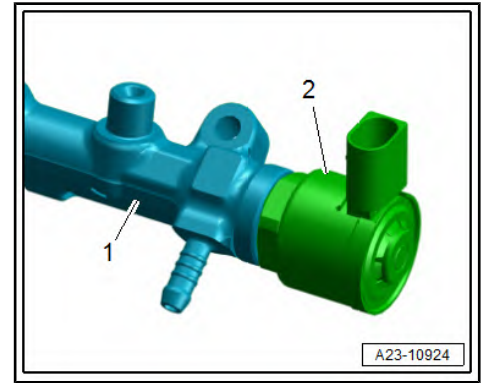

- Connect test hose -2- to return line connection of high-pressure reservoir -3-.

### 1) Checking while engine is running

- Start engine and run at idling speed.
- Engine codes CXXA and CXXB return flow rate 0 ml in 30 seconds. Drip leaks are permissible
- All other engine codes, specified value in 30 seconds over 75 ml.

If the specification is not attained, the fuel pressure regulating valve - N276- is defective.

### 2) Checking while engine is running

If condition in 1) is met, increase engine speed  $\geq 2000$  rpm.

- Return flow rate specification: 0 ml
- Drip leaks are permissible
- If the specification is not attained, the fuel pressure regulating valve - N 276- is defective.

### 3) If it is no longer possible to start engine

Carry out check with starting speed.

- Return flow rate specification: 0 ml
- Drip leaks are permissible
- If the specification is not attained, the fuel pressure regulating valve - N 276- is defective.
- Install engine cover panel [⇒ page 56](#) .

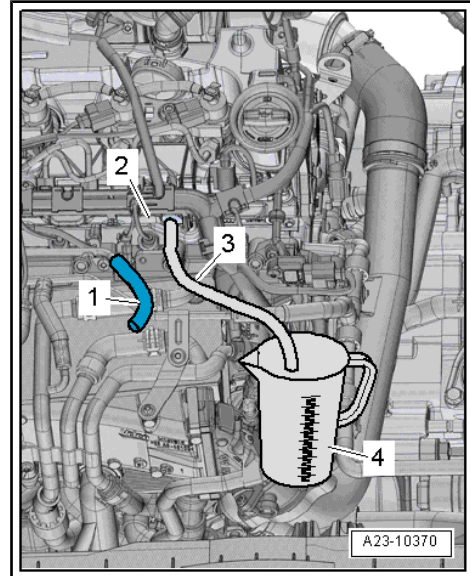

## 6.3 Removing and installing fuel pressure sensor - G247-

### Special tools and workshop equipment required

- ◆ Socket bit 27 mm - T40218-

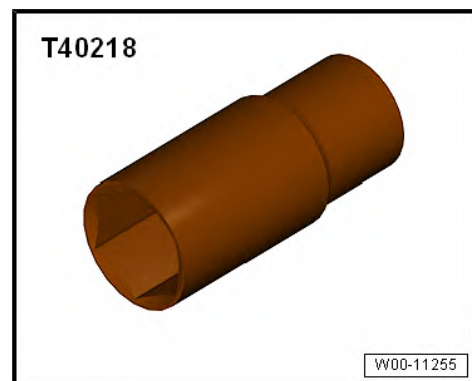

### Removal

- Remove engine cover. [⇒ page 56](#)
- Before removal, clean area around thread for fuel pressure sender - G247- using e.g. commercial cleaning solution.
- Make sure no dirt gets into opening in high-pressure reservoir.
- No cleaning agent is to get into the connector, clean carefully.
- Dry fuel pressure sender - G247- .

- Disconnect electrical connector -arrow-.
- Unscrew fuel pressure sender - G247- using socket, 27 mm - T40218- .
- Vacuum the dirt away from the bore of the high-pressure reservoir (thread and the sealing surface). Do not use tools or other instruments for this purpose.
- Seal off opening in high-pressure reservoir with a plug.

#### Installation



#### Note

- ◆ *Check that sealing surfaces (deformable sealing lip) and threads on fuel pressure sender - G247- are not damaged. If inspection of fuel pressure sender - G247- shows that it is OK, it can be used again.*
  - ◆ *Also check sealing surface on the borehole of the high-pressure reservoir.*
  - ◆ *The beginning of the thread and the deformable sealing lip of the fuel pressure sender - G247- must be coated with diesel fuel.*
- Tighten fuel pressure sender - G247- by hand.
  - Then tighten fuel pressure sender - G247- to specified torque.
  - Fill/bleed fuel system ⇒ [page 293](#) .
  - Install engine cover panel ⇒ [page 56](#) .

#### Specified torques

- ◆ ⇒ ["3.2 Exploded view - high-pressure reservoir \(rail\)"](#), [page 299](#)

## 6.4 Air mass meter - G70- / intake air temperature sender - G42- : Removal and installation



#### Note

*The air mass meter - G70- and the intake air temperature sender - G42- are integrated in one housing.*

#### Special tools and workshop equipment required

- ◆ Hose clip pliers - VAS 6362-

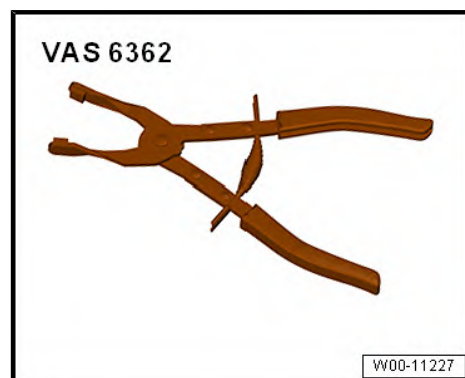
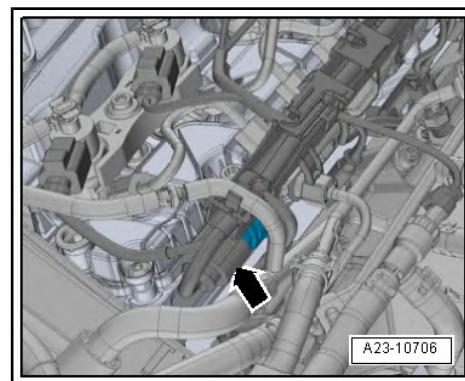

## Removal

- Remove engine cover. ⇒ [page 56](#)
- Free vacuum hoses -arrows-.
- Loosen hose clips -1, 2- and remove air pipe.
- Release and pull off connector.

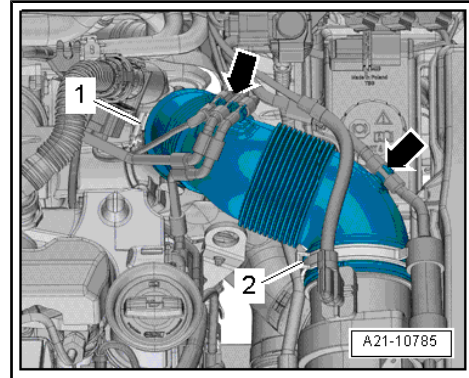

- Unscrew the bolt -1-.
- Turn the air mass measurer - G70- -item 2- in the direction of the arrow B- and take it off.

## Installation

To ensure the proper function of the air mass meter - G70- it is important to observe the following instructions.



### Note

- ◆ *If the air filter element is very dirty or wet, particles of dirt or water may reach the air mass meter and falsify the measured air mass value. This would lead to loss of power, since a smaller injection quantity is calculated.*
- ◆ *Always use genuine part for air filter element.*
- ◆ *Always renew seal if damaged (air leaks in intake system).*
- ◆ *Use a silicone-free lubricant to install the air hose and seal.*
- ◆ *Hose unions and air intake pipes/hoses must be free of oil and grease when installing.*
- ◆ *Secure all hose connections with the hose clips corresponding to original equipment ⇒ [Electronic parts catalogue](#) .*
- Check for salt residue, dirt and leaves in air mass meter and air intake hose (engine intake side).
- Check intake channel for contamination as far as air filter element. If contamination is found, remove salt residue, dirt or leaves from air filter housing.
- Bring the air mass measurer - G70- for assembly in -item 2- and turn it in -the direction of the arrow A-.
- Install engine cover panel ⇒ [page 56](#) .

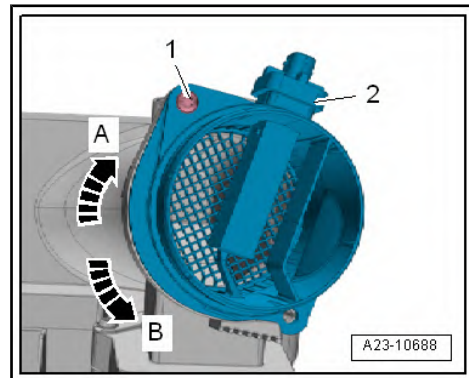

## Specified torques

- ◆ ⇒ [“4.1 Exploded view - air cleaner housing”, page 319](#)
- ◆ ⇒ [“1.1 Exploded view - turbocharger”, page 252](#)

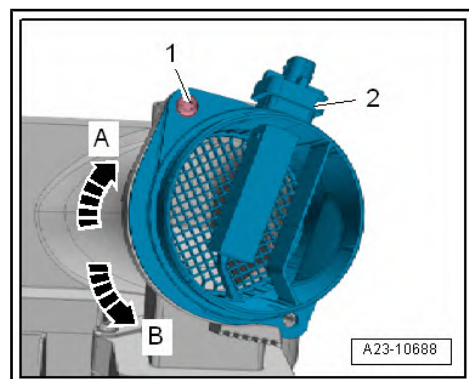

## 6.5 Removing and installing differential pressure sensor - G505-

⇒ [“6.5.1 Removing and installing pressure differential sender G505 , version 1”, page 341](#)

⇒ [“6.5.2 Removing and installing pressure differential sender G505 , version 2”, page 343](#)

⇒ [“6.5.3 Removing and installing pressure differential sender G505 , version 3”, page 344](#)

### 6.5.1 Removing and installing pressure differential sender - G505- , version 1

If the pressure differential sensor - G505- is to be removed  
⇒ [page 341](#) :

If the pressure differential sender - G505- and the pressure sensor 1 for exhaust - G450- are to be removed from the cylinder head cover ⇒ [page 342](#) :



#### Note

*Differential pressure sensor - G505- determines charge status of particulate filter.*

#### Removal of the differential pressure sensor - G505- :

- Remove engine cover. ⇒ [page 56](#)
- Open heat insulation sleeve -1-.
- Release and unplug electrical connector -8-.
- Unscrew bolt -2-, and remove pressure differential sender - G505- -3- from bracket.
- Before disconnecting hose from pressure differential sender - G505- , spray hose with suitable release agent.
- Release the hose clamp -9-.

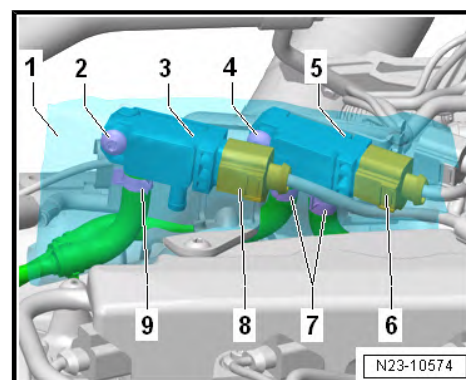

#### Caution

*Avoid irreparable damage to differential pressure sensor caused by the connection breaking off.*

- ◆ *Carefully disconnect hose from connection, taking care to keep hose straight.*

If the pressure differential sender - G505- and the pressure sensor 1 for exhaust - G450- are to be removed from the cylinder head cover:

- Remove engine cover. ⇒ [page 56](#)
- Open heat insulation sleeve -1-.
- Release and disconnect the electrical connectors -3- and -4-.
- Unlock electrical connector -5- and unhook from bracket.
- Open the heat insulation of the connector -6-.
- Release and unplug electrical connector -6-.
- Move clear electrical wiring harness.
- Unscrew bolt -2-.
- Lay the pressure differential sender - G505- with bracket to one side.

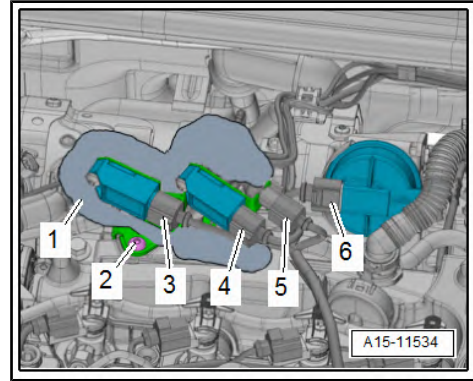

### Installation

Carry out installation in the reverse sequence, noting the following:



#### Note

- ◆ *Before installing, blow out control lines of pressure differential sender - G505- to particulate filter with compressed air towards particulate filter (blocked or iced up due to condensation).*
- ◆ *Make sure that hose is securely fitted and that there are no leaks.*
- ◆ *Secure all hose connections with the correct type of hose clips (same as original equipment) ⇒ Electronic parts catalogue .*
- Install engine cover panel ⇒ [page 56](#) .
- Adaptation must be performed after renewing differential pressure sensor - G505- and/or particulate filter.
- Use ⇒ Vehicle diagnostic tester.
- ◆ `Self-diagnosis-capable systems`
- ◆ `0001 - Engine electronics`
- ◆ `0001 - Engine electronics, functions`
- ◆ `0001 - Reset adaptation values of engine ctrl. module`

### Specified torques

Component	Tightening torque
Bolt for securing bracket to cylinder head	8 Nm

- ◆ ⇒ [“9.1 Exploded view - Lambda probe”, page 361](#)
- ◆ ⇒ [“2.1 Assembly overview - emission control”, page 385](#)

## 6.5.2 Removing and installing pressure differential sender - G505- , version 2

If the pressure differential sensor - G505- is to be removed  
 ⇒ [page 343](#) :

If the pressure differential sensor - G505- is to be removed from  
 the cylinder head cover ⇒ [page 344](#) :

### Note

*Differential pressure sensor - G505- determines charge status of particulate filter.*

- Remove engine cover. ⇒ [page 56](#)

#### Removal of the differential pressure sensor - G505- :

- Open heat insulation sleeve -4-.
- Release and unplug electrical connector -3-.
- Unscrew bolt -1-, and remove pressure differential sender - G505- -2- from bracket.
- Unlock the bracket -8- on the rear side from the bracket -7- and remove.
- Before disconnecting hose from pressure differential sender - G505- , spray hose with suitable release agent.
- Release the hose clamp -10-.
- Pull off the coolant hoses -9- from the tube connections.

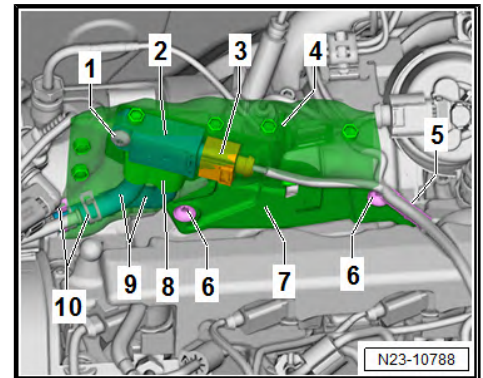

### Caution

*Avoid irreparable damage to differential pressure sensor caused by the connection breaking off.*

- ◆ *Carefully disconnect hose from connection, taking care to keep hose straight.*

If the pressure differential sensor - G505- is to be removed from the cylinder head cover:

- Open heat insulation sleeve -1-.
- Release and unplug electrical connector -3-.
- Unclip and free wiring harness -5-.
- Remove bolts -6-.
- Lay the pressure differential sender - G505- with bracket -7- to one side.

### Installation

Carry out installation in the reverse sequence, noting the following:

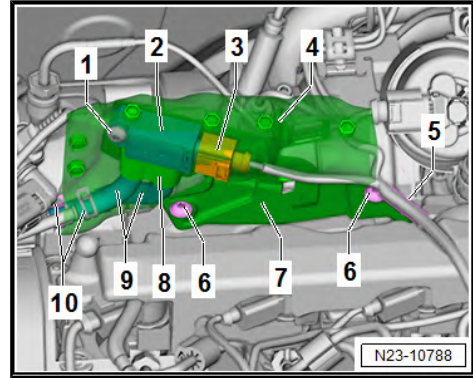

### Note

- ◆ Before installing, blow out control lines of pressure differential sender - G505- to particulate filter with compressed air towards particulate filter (blocked or iced up due to condensation).
- ◆ Make sure that hose is securely fitted and that there are no leaks.
- ◆ Secure all hose connections with the correct type of hose clips (same as original equipment) ⇒ *Electronic parts catalogue* .

- Install engine cover panel ⇒ [page 56](#) .
- Adaptation must be performed after renewing differential pressure sensor - G505- and/or particulate filter.
- Use ⇒ Vehicle diagnostic tester.

- ◆ `Self-diagnosis-capable systems`
- ◆ `0001 - Engine electronics`
- ◆ `0001 - Engine electronics, functions`
- ◆ `0001 - Reset adaptation values of engine ctrl. module`

### Specified torques

Component	Tightening torque
Bolt for securing bracket to cylinder head	8 Nm

- ◆ ⇒ [“9.1 Exploded view - Lambda probe”, page 361](#)
- ◆ ⇒ [“2.1 Assembly overview - emission control”, page 385](#)

## 6.5.3 Removing and installing pressure differential sender - G505- , version 3

### Note

Differential pressure sensor - G505- determines charge status of particulate filter.

## Removal

- Remove engine cover. ⇒ [page 56](#)
- Open heat insulation sleeve -1-.
- Unplug the electrical connector -4-.
- Remove bolt -3- and detach pressure differential sender - G505- from bracket.
- Before disconnecting hose from pressure differential sender - G505- , spray hose with suitable release agent.
- Loosen the clamp -2-.

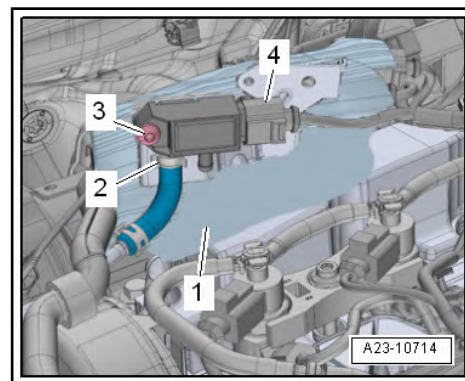

### Caution

*Irreparable damage to pressure differential sender can be caused if the connection breaks off.*

- ◆ *Carefully disconnect hose from connection, taking care to keep hose straight.*

## Installation

Installation is carried out in the reverse order; note the following:



### Note

- ◆ *Before installing, blow out control lines of pressure differential sender - G505- to particulate filter with compressed air towards particulate filter (blocked or iced up due to condensation).*
- ◆ *Make sure that hose is securely fitted and that there are no leaks.*
- ◆ *Secure all hose connections with the correct type of hose clips (same as original equipment) ⇒ Electronic parts catalogue .*
- Install engine cover panel ⇒ [page 56](#) .
- Adaptation must be performed after renewing differential pressure sensor - G505- and/or particulate filter.
- This will cause the learnt values to be reset.
- Perform adaption. For this purpose, use Vehicle diagnostic and service information system .

## Specified torques

- ◆ ⇒ ["9.1 Exploded view - Lambda probe", page 361](#)
- ◆ ⇒ ["2.1 Assembly overview - emission control", page 385](#)

## 6.6 Removing and installing exhaust gas pressure sensor 1 - G450-

### Removal

- Remove engine cover. ⇒ [page 56](#)

- Open heat insulation sleeve -1-.
- Unplug the electrical connector -8-.
- Remove bolt -2-; Pressure differential sender - G505- -3- push a little to one side.
- Unplug the electrical connector -6-.
- Unscrew the bolt -4-.
- Before removal spray solvent onto the hose of the exhaust pressure sender 1 - G450- -5-.
- Release hose clips -7-.

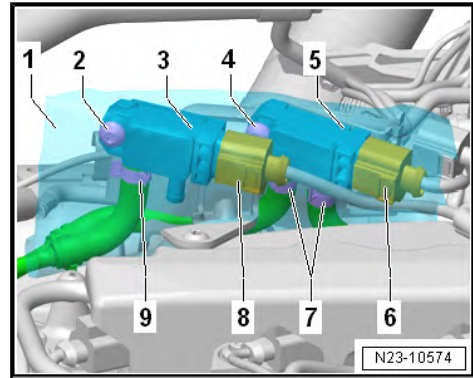

### Caution

**Irreparable damage to pressure differential sender can be caused if the connection breaks off.**

- ◆ **Carefully disconnect hose from connection, taking care to keep hose straight.**

### Installation

Installation is carried out in the reverse order; note the following:



### Note

- ◆ *Before installing, blow out control lines for exhaust gas pressure sensor 1 - G450- towards particulate filter with compressed air (hoses can become obstructed or may ice up due to condensation).*
- ◆ *Make sure that hose is securely fitted and that there are no leaks.*
- ◆ *Secure all hose connections with the correct type of hose clips (same as original equipment) ⇒ Electronic parts catalogue .*
- Install engine cover panel ⇒ [page 56](#) .
- After renewing pressure differential sender -G450- reset learnt values ⇒ Vehicle diagnostic tester.
- Perform adaption. For this purpose, use Vehicle diagnostic and service information system .

- ◆ `Self-diagnosis-capable systems`
- ◆ `0001 - Engine electronics`
- ◆ `0001 - Engine electronics, functions`
- ◆ `0001 - Reset adaptation values of engine ctrl. module`

### Specified torques

- ◆ Lambda probe - exploded view  
⇒ ["9.1 Exploded view - Lambda probe", page 361](#)
- ◆ Exploded view - emission control system  
⇒ ["2.1 Assembly overview - emission control", page 385](#)

## 6.7 Removing and installing charge air temperature sender ahead of charge air cooler - G810-

### Removal

- Remove engine cover. ⇒ [page 56](#)
- Release and pull off respective connector -2-.
- 1 - Charge air temperature sender after charge air cooler - G811-
- 2 - Charge air temperature sender before charge air cooler - G810-
- Unscrew relevant charge air temperature sender.

### Installation

Installation is carried out in the reverse order; note the following:

- Install engine cover panel ⇒ [page 56](#) .

### Specified torques

- ◆ ⇒ [“5.1 Exploded view - intake manifold”, page 323](#)

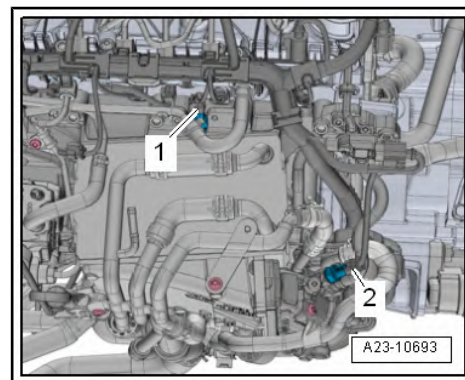

## 6.8 Removing and installing charge air temperature sender after charge air cooler - G811-

### Removal

- Remove engine cover. ⇒ [page 56](#)
- Disconnect associated electrical connector -1-:
- 1 - Charge air temperature sender after charge air cooler - G811-
- 2 - Charge air temperature sender before charge air cooler - G810-
- Unscrew relevant charge air temperature sender.

### Installation

Installation is carried out in the reverse order; note the following:

- Install engine cover panel ⇒ [page 56](#) .

### Specified torques

- ◆ ⇒ [“5.1 Exploded view - intake manifold”, page 323](#)

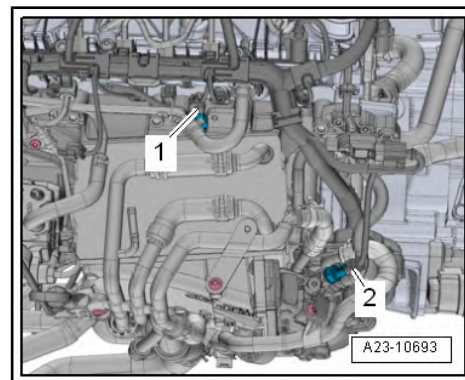

## 6.9 Removing and installing fuel temperature sender - G81-

### Removal

Special tools and workshop equipment required

- ◆ Torque wrench - VAS 6854-

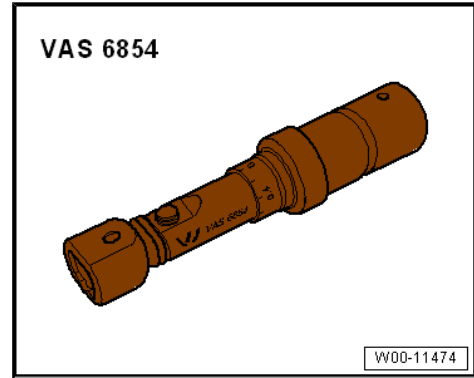

- ◆ Tool set - T10395/3-

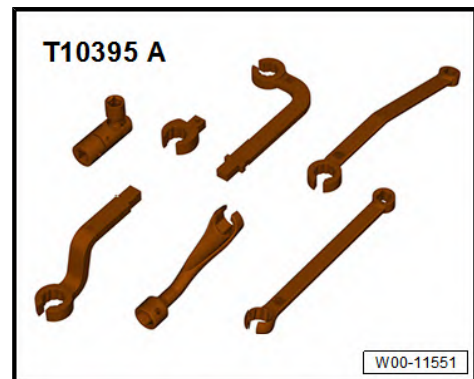

### Removing

- Remove engine cover. ⇒ [page 56](#)
- Unplug the electrical connector -1-.



### WARNING

*The fuel line is under pressure!*

*Risk of injury to eyes and skin from fuel.*

*Wear eye protection and protective clothing to avoid eye injuries and skin contact. Before loosening hose connections, wrap a cloth around the connection. Then release pressure by carefully opening the connection point.*

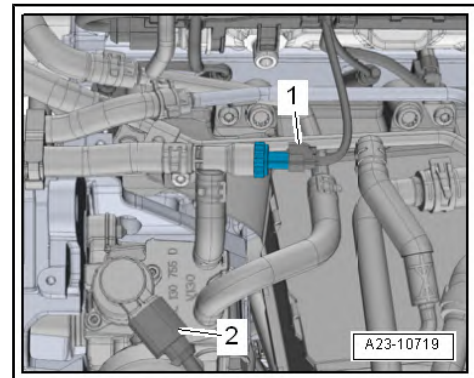

- Unscrew the fuel temperature sender - G81- .
- Collect escaping fuel with a cleaning cloth.



### Note

*Item -2- can be disregarded.*

### Installation

Installation is carried out in the reverse order; note the following:

- Replace the seal -3-.
- Make sure that seal -2- is firmly seated.
- Screw fuel temperature sender - G81- -1- into adapter -4-.
- Check fuel system for leaks ⇒ [page 294](#) .
- Install engine cover panel ⇒ [page 56](#) .

**Tightening torque**

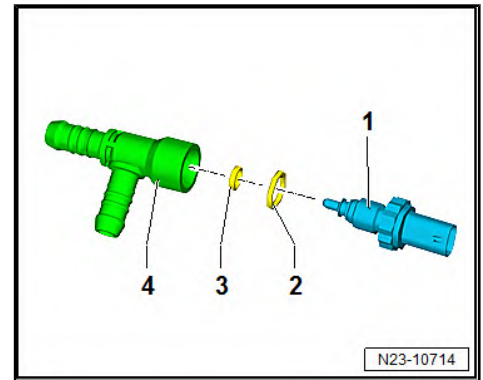

Component	Tightening torque
Fuel temperature sender - G81-	2 Nm

## 7 Engine control unit

⇒ [“7.1 Removing and installing engine control unit J623”, page 350](#)

⇒ [“7.2 Removing and installing engine control unit J623 \(with protective housing\)”, page 351](#)

### 7.1 Removing and installing engine control unit - J623-

#### Special tools and workshop equipment required

- ◆ Vehicle diagnosis and service information system

#### Removing

- If the engine control unit is to be renewed, switch on ignition and select the following menu items in the Vehicle diagnostic and service information system :
  - ◆ 0001 - Engine electronics
  - ◆ 0001 - Engine electronics, functions
  - ◆ 0001 - Renew engine control unit
- Switch off ignition and remove key.



#### Note

*If the engine control unit comes into contact with the positive battery terminal, permanent damage to the engine control unit will be the consequence. For this reason, the battery always needs to be disconnected prior to removing the engine control unit from its bracket ⇒ Electrical system; Rep. gr. 27; Battery; Disconnecting and connecting battery .*

- Release retainer -arrow A- and take out engine control unit - J623- -arrow B-.
- Release and unplug connectors for engine control unit - J623- .

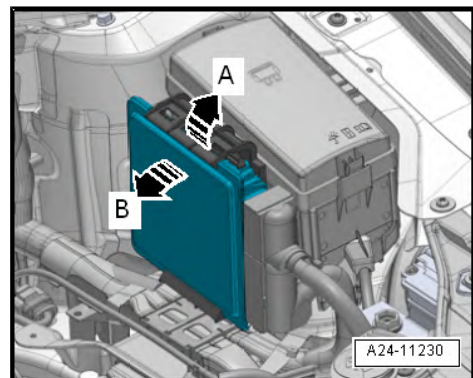

## Installation

Installation is carried out in the reverse order; note the following:

- Insert engine control unit - J623- bottom edge first into bracket -arrow A- and lock at top edge.
- Lugs on engine control unit must engage in notches at top and bottom of bracket -arrows B-.
- Connect vehicle battery => Electrical system; Rep. gr. 27 ; Battery; Disconnecting and connecting battery .

**After installing a new engine control unit, the following operation must be performed:**

- Switch on the ignition and, in the vehicle diagnostics tester , select the following menu items:
  - ◆ 0001 - Engine electronics
  - ◆ 0001 - Engine electronics, functions
  - ◆ 0001 - Renew engine control unit

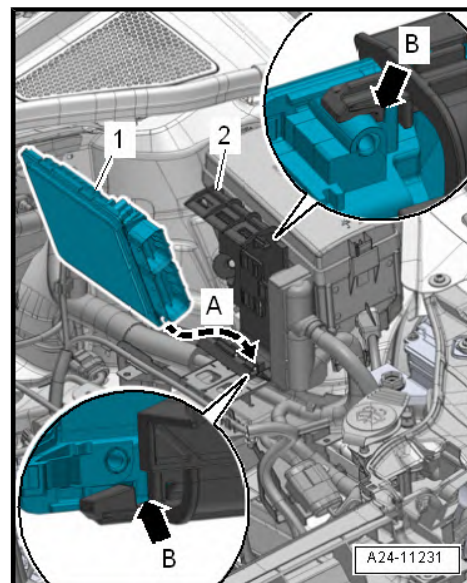

## 7.2 Removing and installing engine control unit - J623- (with protective housing)

=> ["7.2.1 Removing and installing engine control unit J623 \(with metal locking plate\)", page 351](#)

=> ["7.2.2 Removing and installing engine control unit J623 \(with protective housing\)", page 353](#)

### 7.2.1 Removing and installing engine control unit - J623- (with metal locking plate)

#### Special tools and workshop equipment required

- ◆ Hot air blower - VAS 1978/14A- -item 1- with nozzle attachment -2- from wiring harness repair set - VAS 1978 B-

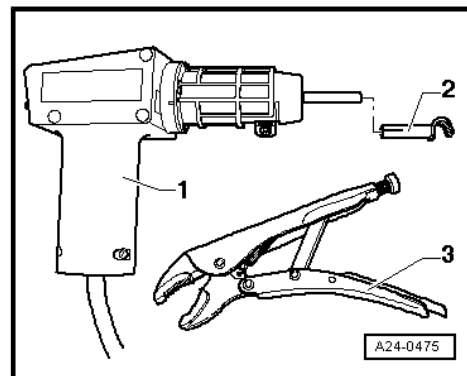

- ◆ Commercially available miniature grinding device
- ◆ Vehicle diagnosis tester

#### Removal

- If the engine control unit is to be renewed, switch on ignition and select the following menu items in the Vehicle diagnostic and service information system :
  - ◆ 0001 - Engine electronics
  - ◆ 0001 - Engine electronics, functions
  - ◆ 0001 - Renew engine control unit
- Switch off ignition and remove key.

**i** Note

*If the engine control unit comes into contact with the positive battery terminal, permanent damage to the engine control unit will be the consequence. For this reason, the battery always needs to be disconnected prior to removing the engine control unit from its bracket ⇒ Electrical system; Rep. gr. 27; Battery; Disconnecting and connecting battery .*

- Release retaining clip -arrow- and take out engine control unit - J623- .

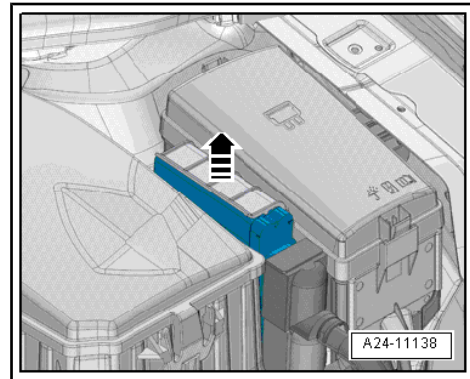

- Using a miniature grinding device -2- grind a groove in the head of the shear bolt -1- so that you can put a screwdriver in it.

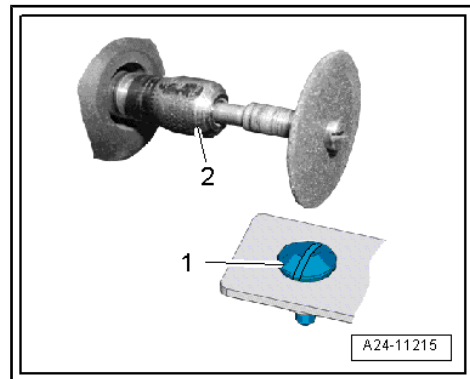

**i** Note

*The shear-head bolt threads are coated with locking compound. To unscrew these bolts, the threads must therefore be heated with the hot air blower.*

- Set hot air blower as shown in illustration. Set potentiometer for temperature setting -2- to maximum heating output and 2-stage switch for air volume -3- to position 3.

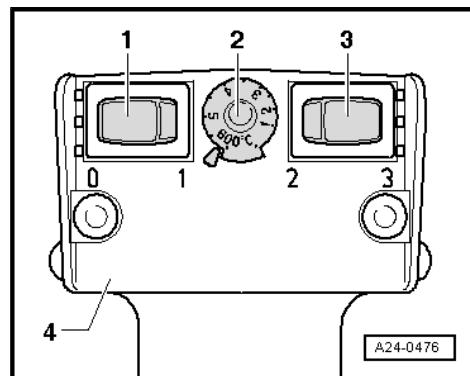

**WARNING**

*Risk of burns from hot air blower.*

- ◆ *Heating the thread of the locking plate also heats up the shear bolts and parts of the metal housing. Ensure to only heat up the thread and no surrounding components. These should be covered if necessary.*

- Hold hot air blower - VAS 1978/14A- with nozzle attachment -arrow- to thread. Heat shear bolts for approx. 20 to 30 seconds.

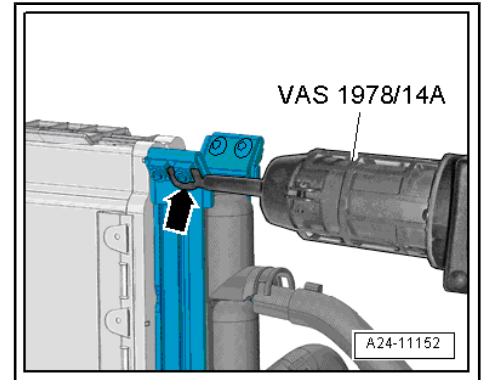

- Unscrew shear bolt -1- using screwdriver -2-.
- Detach metal locking plate from connectors for engine control unit - J623- .
- Release and detach connectors.

### Installation

Installation is carried out in the reverse order; note the following:

- The metal locking plate must always be re-fitted on the engine control unit - J623- .
- Clean threaded holes for shear bolts to remove any residue from locking fluid. This can be done using a thread tap.
- Always use new the shear bolts.

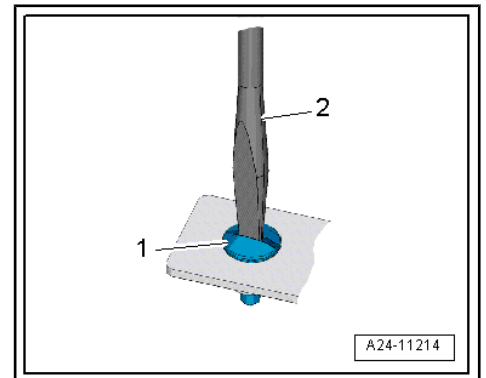

**After installing a new engine control unit, the following operation must be performed:**

- Switch on the ignition and, in the vehicle diagnostics tester , select the following menu items:
  - ◆ 0001 - Engine electronics
  - ◆ 0001 - Engine electronics, functions
  - ◆ 0001 - Renew engine control unit

## 7.2.2 Removing and installing engine control unit - J623- (with protective housing)

### Removal

To remove protective housing -1-, unscrew shear bolts -arrows- as follows:

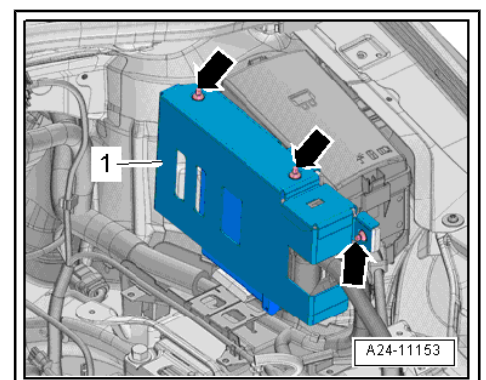

- Make groove (for a screwdriver) in head of shear bolt -1- using a small grinder -2-.

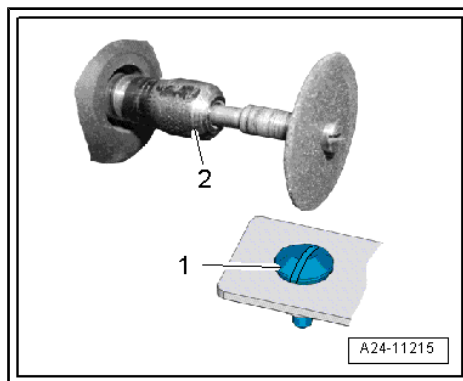

**i Note**

*The shear-head bolt threads are coated with locking compound. To unscrew these bolts, the threads must therefore be heated with the hot air blower.*

- Set hot air blower as shown in illustration. Set potentiometer for temperature setting -2- to maximum heating output and 2-stage switch for air volume -3- to position 3.

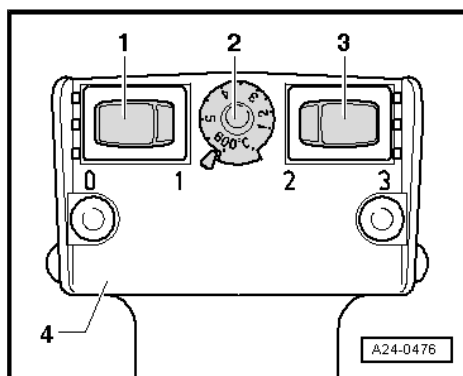

**WARNING**

*Risk of burns from hot air blower.*

- ◆ *Heating the thread of the locking plate also heats up the shear bolts and parts of the metal housing. Ensure to only heat up the thread and no surrounding components. These should be covered if necessary.*

- Heat head of shear bolt -1- for approx. 20 to 30 seconds.

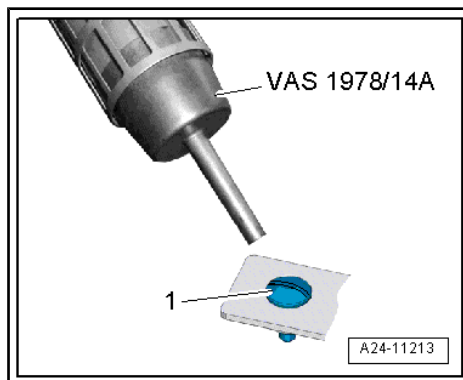

- Unscrew shear bolt -1- using screwdriver -2-.

**i Note**

*If the engine control unit comes into contact with the positive battery terminal, permanent damage to the engine control unit will be the consequence. For this reason, the battery always needs to be disconnected prior to removing the engine control unit from its bracket => Electrical system; Rep. gr. 27 ; Battery; Disconnecting and connecting battery .*

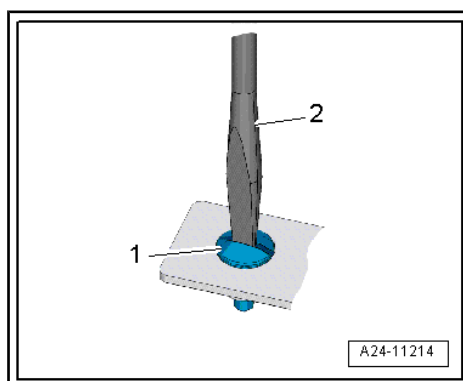

- Release fastener -arrow- and detach engine control unit -1-.
- Release and unplug connectors for engine control unit - J623-.

### Installation

Installation is carried out in the reverse order; note the following:

- Make sure you fit protective housing back on engine control unit - J623- .
- Clean threaded holes for shear bolts to remove any residue from locking fluid. This can be done using a thread tap.
- Always use new the shear bolts.

**After installing a new engine control unit, the following operation must be performed:**

- Switch on ignition and select the following menu items in the vehicle diagnostic and service information system :
  - ◆ `0001 - Engine electronics`
  - ◆ `0001 - Engine electronics, functions`
  - ◆ `0001 - Renew engine control unit`

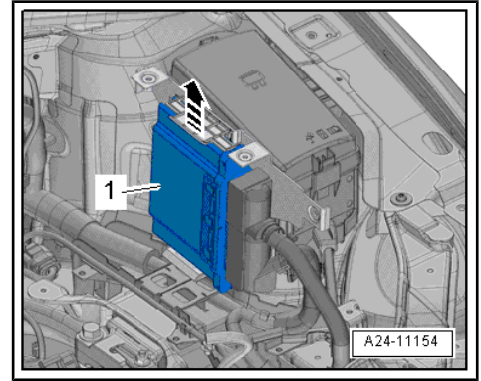

## 8 High-pressure pump

⇒ "8.1 Exploded view - high-pressure pump", page 356

⇒ "8.2 High-pressure pump: removing and fitting", page 357

### 8.1 Exploded view - high-pressure pump

#### 1 - Bracket for ancillary mechanical units

- Removing and fitting  
⇒ [page 61](#)

#### 2 - Bolt.

- 3 off
- Different lengths
- Renew following removal
- Tightening torque:
  - ◆ Short bolt, 20 Nm + 45°
  - ◆ Long bolt, 20 Nm + 180°

#### 3 - High-pressure pump sprocket

#### 4 - Nut

- Use counterholder - T10051- to loosen and tighten.
- 95 Nm

#### 5 - Hub

- To remove, use puller - T10489-

#### 6 - High-pressure pump

- With fuel metering valve - N290- (do not open)
- Removing and fitting  
⇒ [page 357](#)

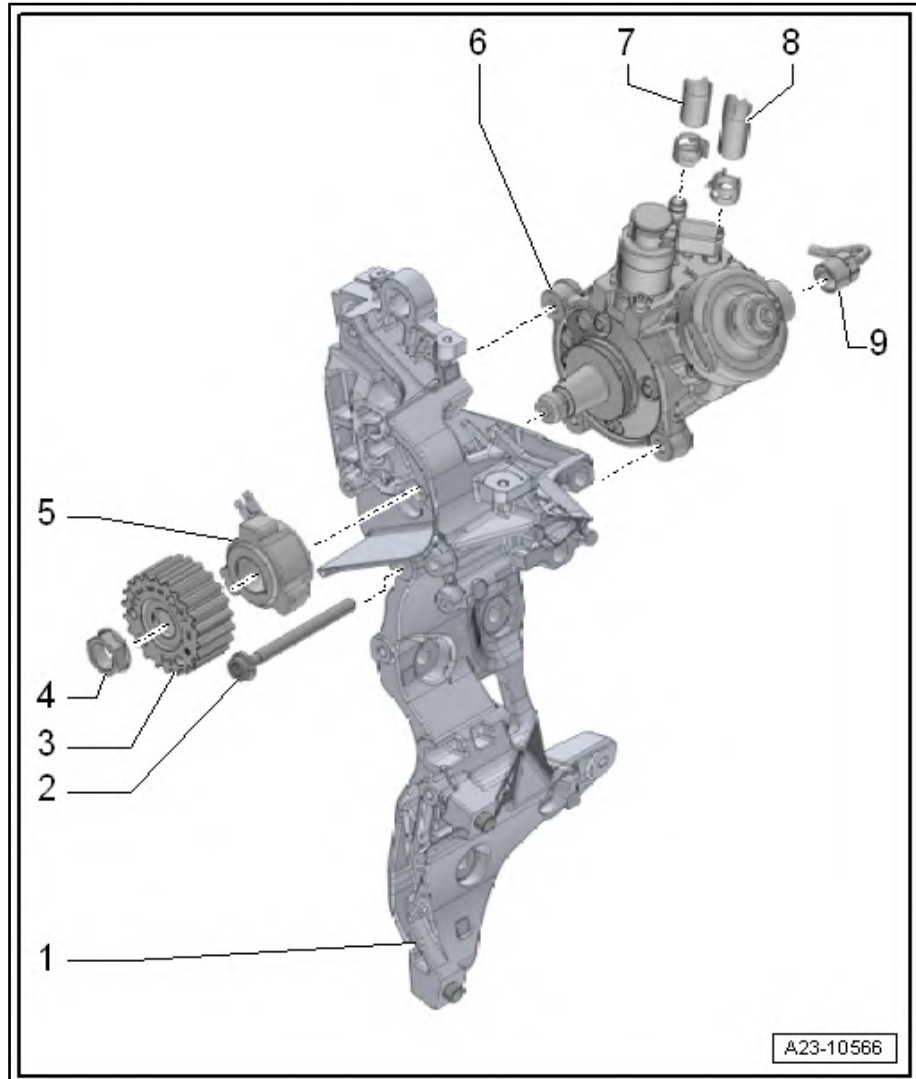

#### Caution

*Running when dry causes irreparable damage to high-pressure pump. When the high-pressure pump is removed or renewed, it is important to fill and bleed the fuel system before the engine is started for the first time*  
⇒ [page 293](#).

- after renewing, re-adapt the learnt values in "Guided Functions" Vehicle diagnostic and service information system

#### 7 - Fuel supply hose

- Engine codes CXXA, CXXB, DDYA, DDYB: as return line
- All other engine codes: As an inlet line

## 8 - Fuel return hose

- Engine codes CXXA, CXXB, DDYA, DDYB: as supply line
- All other engine codes: As a return line

## 9 - High-pressure pipe

- Between high-pressure reservoir (rail) and high-pressure pump
- Removal ⇒ [page 313](#)
- Observe all instructions for installing high-pressure pipes ⇒ [page 313](#)

## 8.2 High-pressure pump: removing and fitting

### Special tools and workshop equipment required

- ◆ retention tool - T10051-

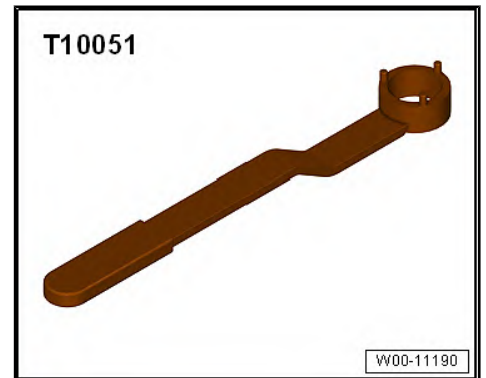

- ◆ Puller - T10489-

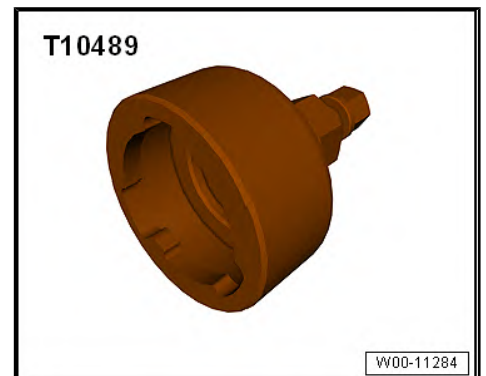

- ◆ Dowel pin -T10492-



## Removal



### Caution

*Risk of malfunctions caused by dirt.*

- ◆ *Observe ⇒ "3.1 Cleaning rules", page 13 .*

*Running when dry causes irreparable damage to high-pressure pump.*

- ◆ *If the high-pressure pump has been removed or renewed, it is important to fill and bleed the fuel system before the engine is started for the first time ⇒ page 293 .*

- Detach toothed belt from camshaft ⇒ [page 120](#) .
- Remove high-pressure pipe between high-pressure reservoir (rail) and high-pressure pump ⇒ [page 313](#) .
- Apply counterhold tool - T10051- to high-pressure pump sprocket.
- Apply counterhold tool - T10051- -A- to high-pressure pump sprocket.
- Hand-tighten nut -arrow-.
- Detach dowel pin -T10492- -B-, slowly turn high-pressure pump shaft to a position in which it is not under tension.
- Remove nut -arrow- and detach counterhold tool - T10051- -A-.
- Detach high-pressure pump sprocket.
  
- Engage puller -T10489- at hub of high-pressure pump by turning it clockwise.
- Detach hub of high-pressure pump.
  
- Remove fuel hoses -2-.
- Unplug the electrical connector -1-.
- Remove bolts -arrows-.
- Carefully take out high-pressure pump.

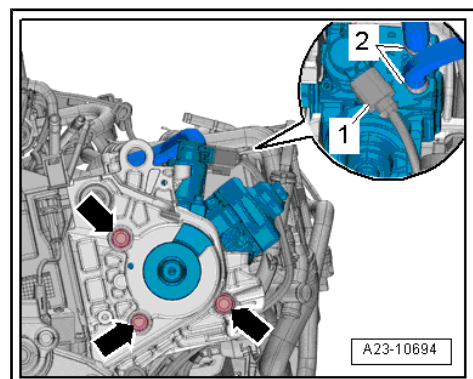
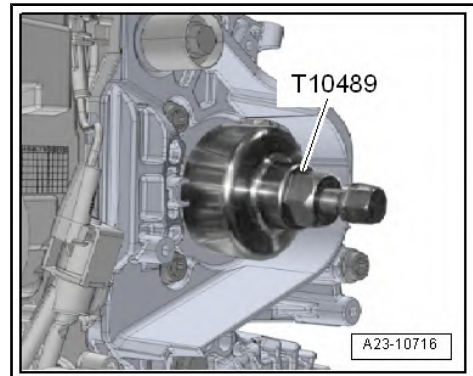
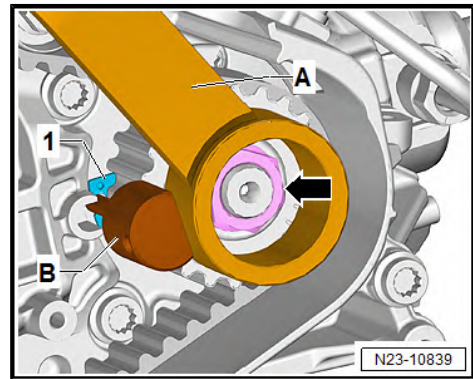

## Installation

Installation is carried out in the reverse order; note the following:

- Apply hub -arrow- to high-pressure pump shaft.
- The parallel key on the high-pressure pump shaft must engage in the groove in the hub.
  
- Place high-pressure pump sprocket on hub.
- Contact surface between counterhold tool and toothed belt sprocket must be free of oil.

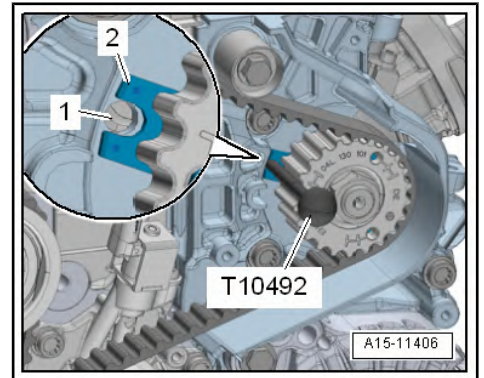
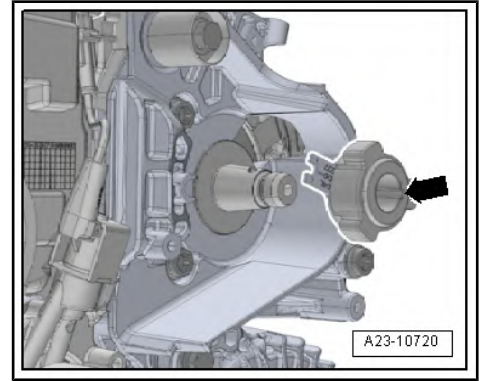

- Screw nut -arrow- onto thread of high-pressure pump shaft.
- Apply counterhold tool - T10051- -A- to toothed belt sprocket and hand-tighten nut -arrow-.
- Turn the high-pressure pump sprocket with counterhold tool - T10051- until it can be locked in position with locking pin - T10492- -B-.
- To do this, insert dowel pin -T10492- into fork -2- on hub and into hole -1- behind it in bracket for ancillaries.
- Loosen nut -arrow- again.
- The gear pinion of the high pressure pump must be turned and should not be pivoted any more.
- Install toothed belt ⇒ [page 120](#) .
- Install high-pressure pipe ⇒ [page 313](#) .

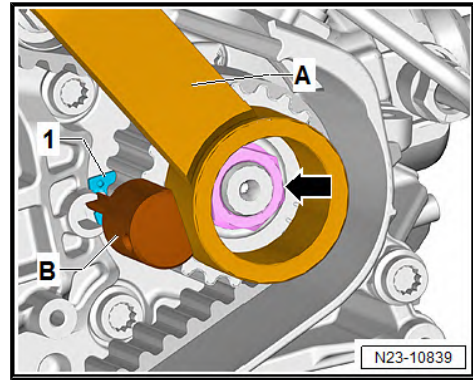

### Caution

***Risk of damage to high-pressure pump when running dry.***

- ◆ ***If the high-pressure pump has been removed or renewed, it is important to fill and bleed the fuel system before the engine is started for the first time ⇒ [page 293](#) .***

- After renewing high-pressure pump, readapt learnt values. For this purpose, use Vehicle diagnostic and service information system .
- ◆ `0001 - Engine electronics`
- ◆ `0001 - Engine electronics, functions`
- ◆ `0001 - Reset adaptation values of engine ctrl. module`

### Specified torques

- ◆ ⇒ ["8.1 Exploded view - high-pressure pump", page 356](#)

## 9 Lambda sensor

⇒ [“9.1 Exploded view - Lambda probe”, page 361](#)

⇒ [“9.2.1 Removing and installing Lambda probe 1 before catalytic converter GX10”, page 362](#)

### 9.1 Exploded view - Lambda probe

#### 1 - Lambda probe 1 after catalytic converter - GX7-

Consisting of: Lambda probe after catalytic converter - G130- and Heater for lambda probe 1, after catalytic converter - Z29-

- If fitted
- Removing and fitting ⇒ [page 363](#)
- Observe fitting instructions ⇒ [page 365](#)
- 52 Nm

#### 2 - Exhaust gas temperature sender 4 - G648-

- If fitted
- Removing and fitting ⇒ [page 416](#)

#### 3 - Exhaust gas temperature sender 1 - G235-

- Removing and fitting ⇒ [page 413](#)

#### 4 - Exhaust gas temperature sender 2 - G448-

- If fitted
- Removing and fitting ⇒ [page 420](#)

#### 5 - Bolt.

- 8 Nm

#### 6 - Pressure differential sender - G505-

- Removing and fitting ⇒ [page 341](#)

#### 7 - Bracket/bearing/support

- For pressure differential sender

#### 8 - Pressure sensor 1 of exhaust gases - G450-

- If fitted
- Removing and fitting ⇒ [page 345](#)

#### 9 - Bolt.

- 8 Nm

#### 10 - Exhaust gas temperature sender 3 - G495-

- Removing and fitting ⇒ [page 416](#)

#### 11 - Lambda sensor 1 before catalytic converter - GX10-

Comprising: lambda probe - G39- with lambda probe heating - Z19- .

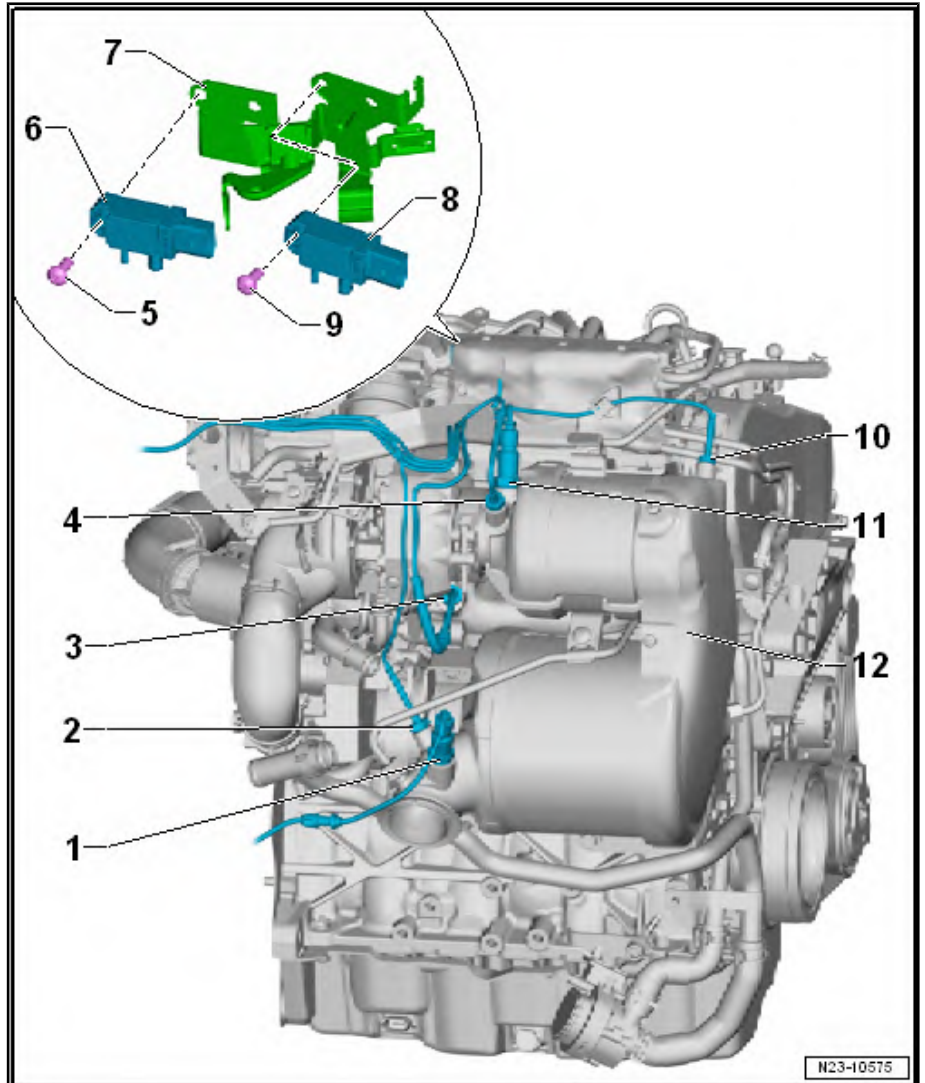

- Removing and fitting ⇒ [page 362](#)
- 55 Nm

## 12 - Emission control module

### 9.2 Removing and installing Lambda probe

⇒ [“9.2.1 Removing and installing Lambda probe 1 before catalytic converter GX10”](#), page 362

⇒ [“9.2.2 Removing and installing Lambda probe 1 after catalytic converter GX7”](#), page 363

#### 9.2.1 Removing and installing Lambda probe 1 before catalytic converter - GX10-

##### Special tools and workshop equipment required

- ◆ Socket, AF 22 - T10491-



##### Removal

- Remove engine cover. ⇒ [page 56](#)
- Remove connector for lambda sensor 1 before catalytic converter - GX10- from retainer, release it, and pull it off ⇒ [page 293](#) .

- Unscrew Lambda probe 1 before catalytic converter - GX10-arrow- using socket 22 mm - T10491- .

### Installation

Installation is carried out in the reverse order; note the following:

#### Note

- ◆ *New Lambda sensors are coated with an assembly paste. The paste must not get into the slots on the lambda sensor body.*
- ◆ *In the case of a used Lambda probe grease only the thread with high-temperature paste. This paste must not get into the slots on the probe body. For high-temperature paste refer to => *Electronic parts catalogue**
- ◆ *When re-installing the electric wire of the lambda sensor, it is important that these are connected to the same locations. The lambda sensor cable must be prevented from touching the exhaust pipe.*

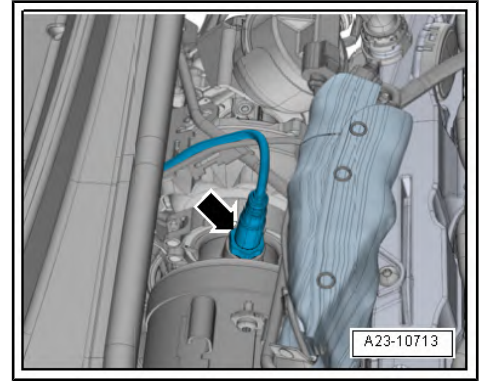

- Install engine cover panel => [page 56](#) .
- ◆ Adaptation must be carried out after renewing the lambda probe.
- ◆ This will cause the learnt values to be reset.
- ◆ Carry out adaptation using a vehicle diagnostic tester .
- ◆ Self-diagnosis-capable systems
- ◆ 0001 - Engine electronics
- ◆ 0001 - Engine electronics, functions
- ◆ 0001 - Reset adaptation values of engine ctrl. module
- Follow instructions on vehicle diagnosis and service information system .

### Specified torques

- ◆ => ["9.1 Exploded view - Lambda probe", page 361](#)

## 9.2.2 Removing and installing Lambda probe 1 after catalytic converter - GX7-

### Special tools and workshop equipment required

- ◆ Lambda probe open ring spanner set - 3337-

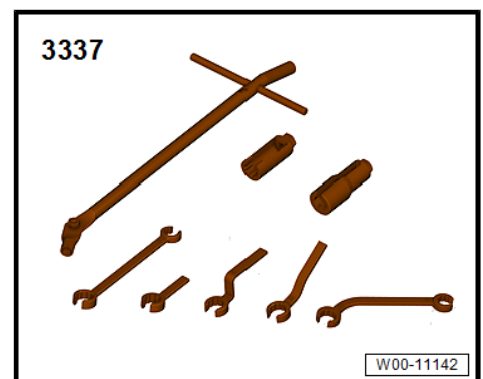

### Removal

- Unscrew both plastic nuts -arrows- from the left undercarriage panel -1- and move the panel slightly downward.

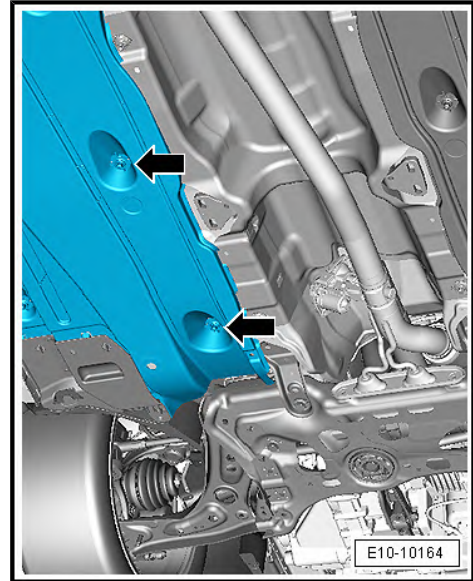

- Take the electrical plug connection -arrow- for lambda sensor 1 after catalytic converter - GX7- out of the bracket, release and pull off.

### Vehicles with four wheel drive:

- Remove front exhaust pipe ⇒ [page 378](#) .

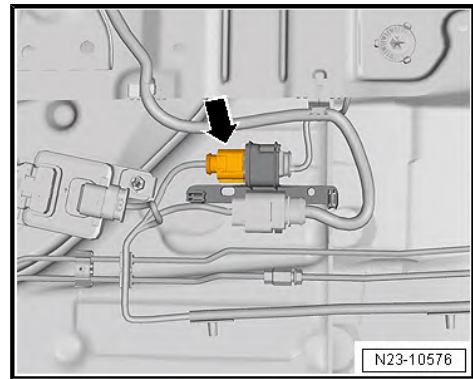

### All vehicles (continued):

- Unscrew lambda probe 1 after catalytic converter - GX7-  
-arrow- using a suitable tool from lambda probe open ring  
spanner set - 3337- .

### Installation

Installation is carried out in the reverse order; note the following:

#### Note

- ◆ *New Lambda sensors are coated with an assembly paste. The paste must not get into the slots on the lambda sensor body.*
- ◆ *In the case of a used Lambda probe grease only the thread with high-temperature paste. The paste must not get into the slots on the Lambda probe body. For high-temperature paste refer to ⇒ *Electronic parts catalogue**
- ◆ *When re-installing the electric wire of the lambda sensor, it is important that these are connected to the same locations. The lambda sensor cable must be prevented from touching the exhaust pipe.*

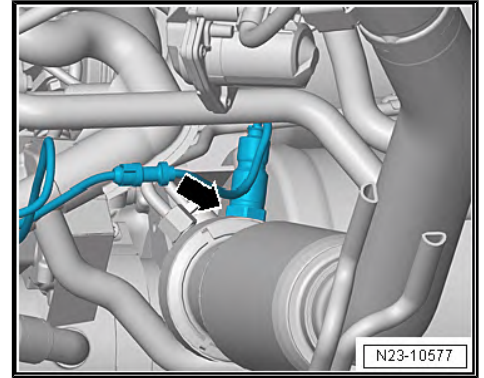

### Specified torques

- ◆ Exploded view - Lambda probe  
⇒ ["9.1 Exploded view - Lambda probe", page 361](#)
- ◆ Exploded view - Silencers  
⇒ ["1.1 Exploded view - silencers", page 366](#)
- ◆ Assembly overview: underbody trim ⇒ Rep. gr. 66 ; under-  
body trim; assembly overview - underbody trim

## 26 – Exhaust system

### 1 Exhaust pipes/silencers

- ⇒ [“1.1 Exploded view - silencers”, page 366](#)
- ⇒ [“1.2 Removing and installing front exhaust pipe with catalytic converter”, page 378](#)
- ⇒ [“1.3 Disconnecting exhaust pipes/silencers”, page 379](#)
- ⇒ [“1.4 Removing and installing rear silencer”, page 382](#)
- ⇒ [“1.5 Align exhaust system to be free of stress”, page 383](#)
- ⇒ [“1.6 Check exhaust system for leaks”, page 384](#)

#### 1.1 Exploded view - silencers

- ⇒ [“1.1.1 Installation overview - noise silencer, vehicle with front wheel drive and multi-link rear axle”, page 366](#)
- ⇒ [“1.1.2 Installation overview - noise silencer, vehicle with front wheel drive and compound crank rear axle”, page 368](#)
- ⇒ [“1.1.3 Installation overview - noise silencer, vehicle with front wheel drive and multi-link rear axle, Leon ST”, page 371](#)
- ⇒ [“1.1.4 Installation overview - noise silencer, vehicle with four wheel drive and multi-link rear axle, Leon ST”, page 374](#)
- ⇒ [“1.1.5 Installation overview - noise silencer, vehicles semi-rigid axle, Leon ST”, page 376](#)

##### 1.1.1 Installation overview - noise silencer, vehicle with front wheel drive and multi-link rear axle

Original equipment as single assembly together with rear silencer; to be renewed individually in event of repair

**1 - Rear silencer**

- Stress-free alignment of exhaust system  
 ⇒ [page 383](#)
- Removing and fitting  
 ⇒ [page 382](#)

**2 - Bolt.**

- 23 Nm

**3 - Suspension element**

- Renew if damaged.

**4 - Mounting**

- Renew if damaged.

**5 - Mounting**

- Renew if damaged.

**6 - Bolt.**

- 20 Nm

**7 - Suspension element**

- Renew if damaged.

**8 - Bolt.**

- 20 Nm

**9 - Bracket/bearing/support**

- Renew if damaged.

**10 - Screw-type clip**

- Renew following removal
- Installation position  
 ⇒ [page 368](#)
- 7 Nm

**11 - Seal**

- Renew following removal
- Note installation position ⇒ [page 368](#) .

**12 - Front exhaust pipe**

- Removing and fitting ⇒ [page 378](#)
- Stress-free alignment of exhaust system ⇒ [page 383](#)

**13 - Nut**

- 9 Nm

**14 - Exhaust flap control unit - J883-**

- Removing and fitting ⇒ [page 410](#)

**15 - Bolt.**

- 10 Nm

**16 - Tension sleeve**

- Align exhaust system so it is free of stress before tightening clamp ⇒ [page 383](#)
- Installation position ⇒ [page 368](#)
- Tighten bolted connections evenly

**17 - Nut**

- Tightening torque ⇒ [page 376](#)

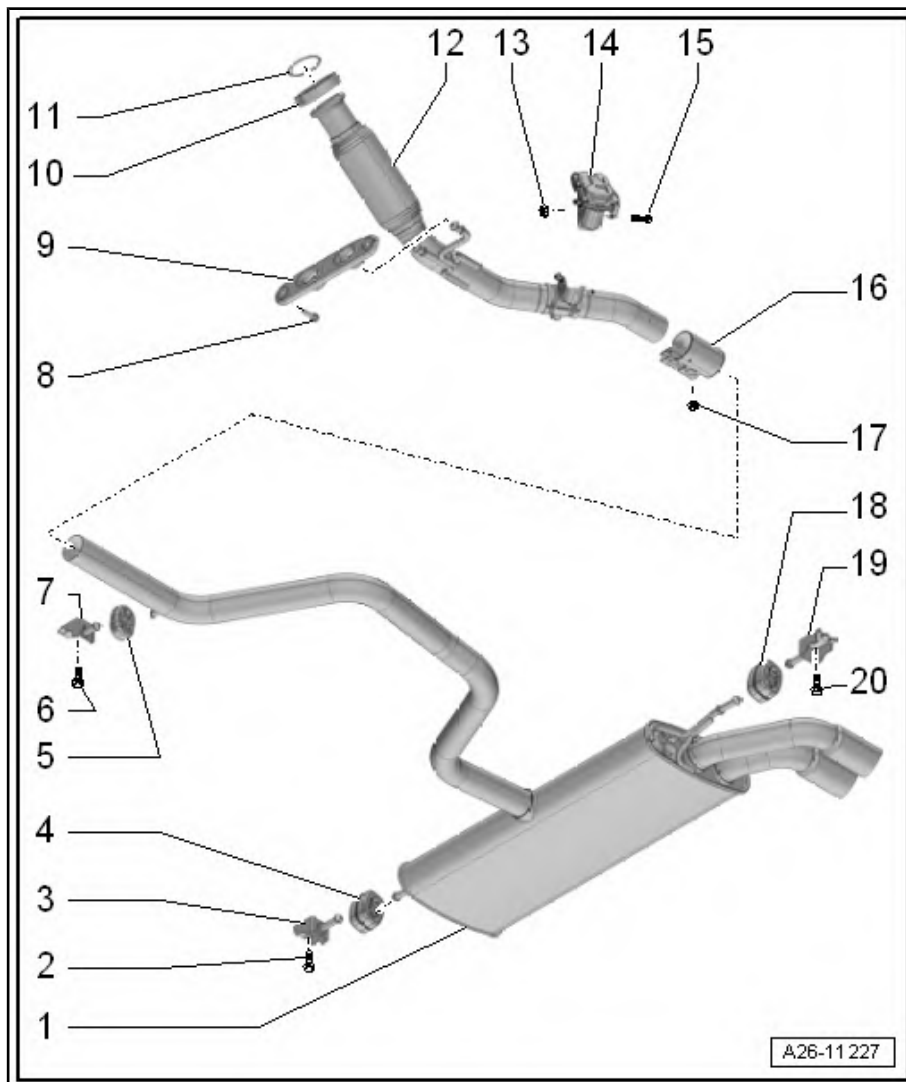

### 18 - Mounting

- Renew if damaged.

### 19 - Suspension element

- Renew if damaged.

### 20 - Bolt.

- 23 Nm

#### Installation position of seal between emission control module and exhaust pipe

- Square tab on seal -arrow- must fit into groove on diesel particulate filter.

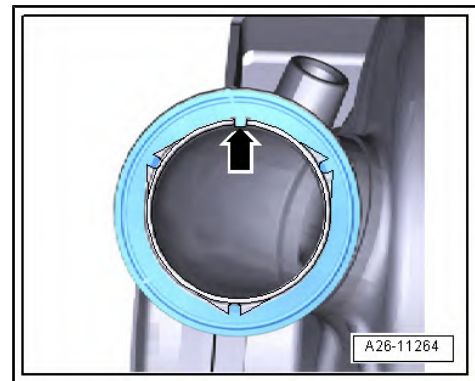

#### Installation position of screw-type clip for front exhaust pipe

- Angle  $-\alpha-$  =  $0 \pm 30^\circ$

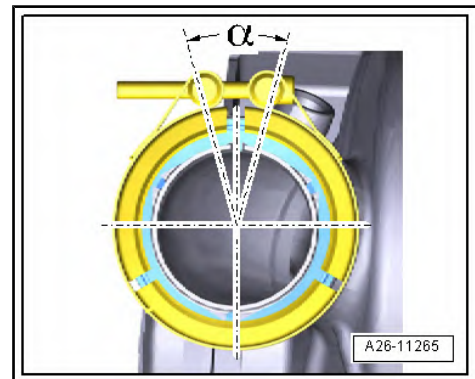

#### Installation position of the clamping sleeve

- Fit the clamp at the angle shown.
- Angle  $-\alpha-$  = approx.  $20^\circ$ .
- Bolt connection facing towards right
- Nuts facing upwards

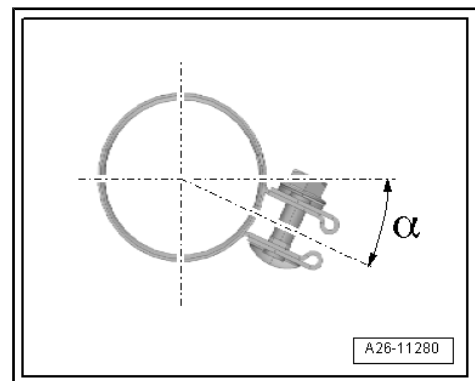

### 1.1.2 Installation overview - noise silencer, vehicle with front wheel drive and compound crank rear axle

Original equipment as single assembly together with rear silencer; to be renewed individually in event of repair

- 1 - Bolt.**
  - 23 Nm
- 2 - Suspension element**
  - Renew if damaged.
- 3 - Mounting**
  - Renew if damaged.
- 4 - Bolt.**
  - 23 Nm
- 5 - Suspension element**
  - Renew if damaged.
- 6 - Mounting**
  - Renew if damaged.
- 7 - Bolt.**
  - 23 Nm
- 8 - Bracket/bearing/support**
  - Renew if damaged.
- 9 - Screw-type clip**
  - Renew following removal
  - Installation position ⇒ [page 368](#)
  - 7 Nm
- 10 - Seal**
  - Renew following removal
  - Note installation position ⇒ [page 368](#).
- 11 - Front exhaust pipe**
  - Removing and fitting ⇒ [page 378](#)
  - Stress-free alignment of exhaust system ⇒ [page 383](#)
- 12 - Nut**
  - 9 Nm
- 13 - Exhaust flap control unit - J883-**
  - Removing and fitting ⇒ [page 410](#)
- 14 - Bolt.**
  - 10 Nm
- 15 - Tension sleeve**
  - Before tightening, align exhaust system so it is free of stress ⇒ [page 383](#)
  - Installation position ⇒ [page 371](#)
  - Tighten bolted connections evenly
- 16 - Nut**
  - Tightening torque ⇒ [page 376](#)
- 17 - Exhaust pipe**
  - Mounting unit with rear silencer
  - With removable connection for easier removal ⇒ [page 379](#)

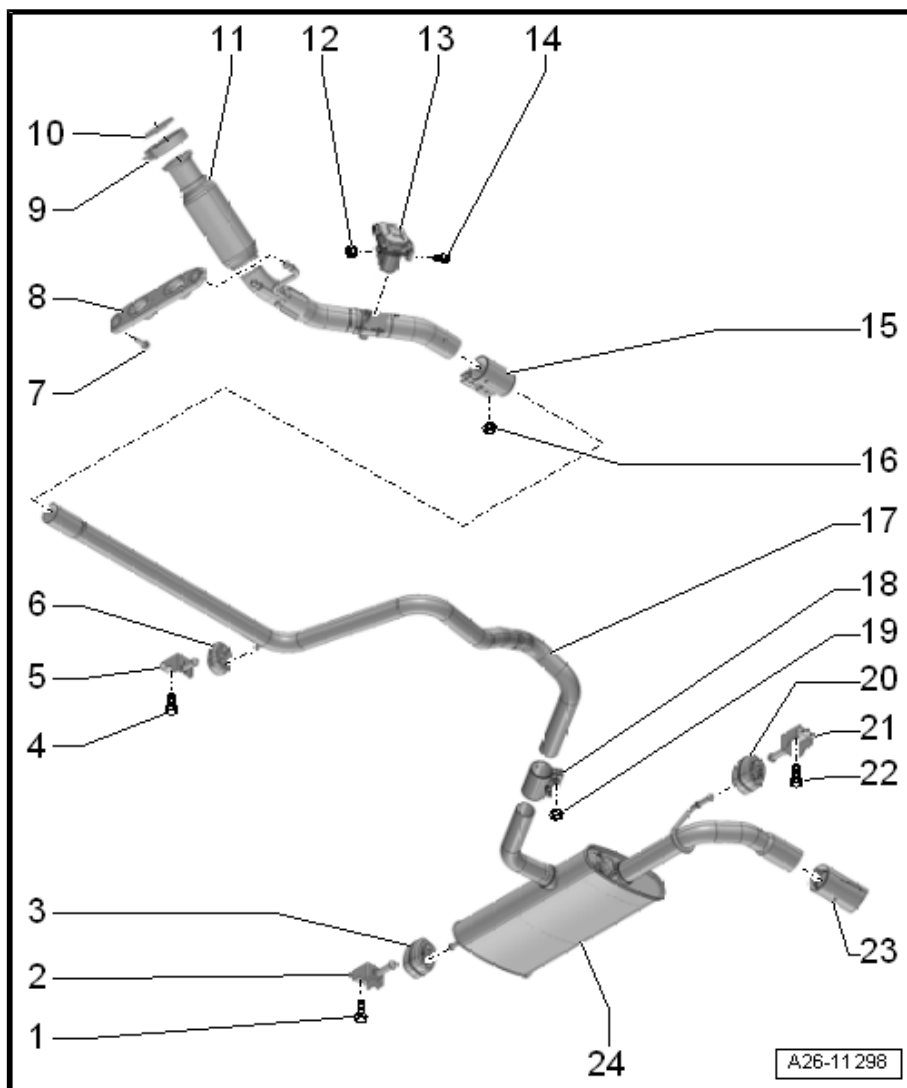

### 18 - Tension sleeve

- Before tightening, align exhaust system so it is free of stress
- Installation position ⇒ [page 371](#)
- Tighten bolted connections evenly

### 19 - Nut

- Tightening torque ⇒ [page 376](#)

### 20 - Mounting

- Renew if damaged.

### 21 - Suspension element

- Renew if damaged.

### 22 - Bolt.

- 23 Nm

### 23 - Tailpipe

- Depending on model

### 24 - Rear silencer

- Stress-free alignment of exhaust system ⇒ [page 383](#)
- Removing and fitting ⇒ [page 382](#)

### Installation position of seal between emission control module and exhaust pipe

- Square tab on seal -arrow- must fit into groove on diesel particulate filter.

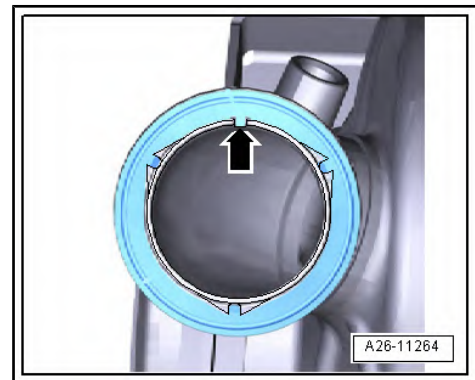

### Installation position of screw-type clip for front exhaust pipe

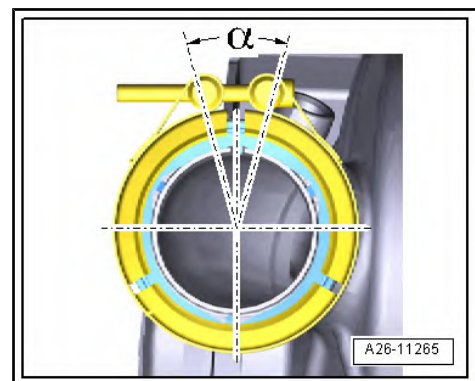

#### Installation position of front clamp

- Fit the clamp at the angle shown.
- Angle  $\alpha$  = approx.  $50^\circ$ .
- Bolt connection facing towards right
- Nuts facing upwards

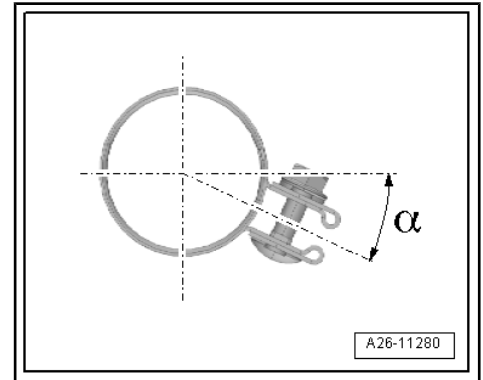

#### Installation position of the rear fastening sleeve.

- Install the fastening sleeve at the angle shown.
- Angle  $\alpha$  = approx.  $20^\circ$
- Bolt connection faces to rear
- Nuts facing upwards

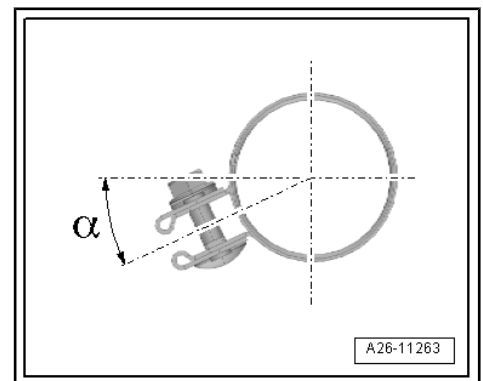

### 1.1.3 Installation overview - noise silencer, vehicle with front wheel drive and multi-link rear axle, Leon ST

Original equipment as single assembly together with rear silencer; to be renewed individually in event of repair

**1 - Bolt.**

**2 - Exhaust flap control unit - J883-**

- Removing and fitting ⇒ [page 410](#)

**3 - Nut**

- 9 Nm

**4 - Bolt.**

- 23 Nm

**5 - Bracket/bearing/support**

- Renew if damaged.

**6 - Front exhaust pipe**

- Removing and fitting ⇒ [page 378](#)
- Stress-free alignment of exhaust system ⇒ [page 383](#)

**7 - Screw-type clip**

- Renew following removal
- Installation position ⇒ [page 373](#)
- 7 Nm

**8 - Seal**

- Renew following removal
- Note installation position ⇒ [page 373](#).

**9 - Tension sleeve**

- Before tightening, align exhaust system so it is free of stress ⇒ [page 383](#)
- Installation position ⇒ [page 373](#)
- Tighten bolted connections evenly

**10 - Nut**

- Tightening torque ⇒ [page 376](#)

**11 - Suspension element**

- Renew if damaged.
- Aligning mounting ⇒ [page 374](#)

**12 - Bolt.**

- 23 Nm

**13 - Mounting**

- Renew if damaged.

**14 - Exhaust pipe**

- Mounting unit with rear silencer
- With removable connection for easier removal ⇒ [page 379](#)

**15 - Suspension element**

- Renew if damaged.

**16 - Mounting**

- Renew if damaged.

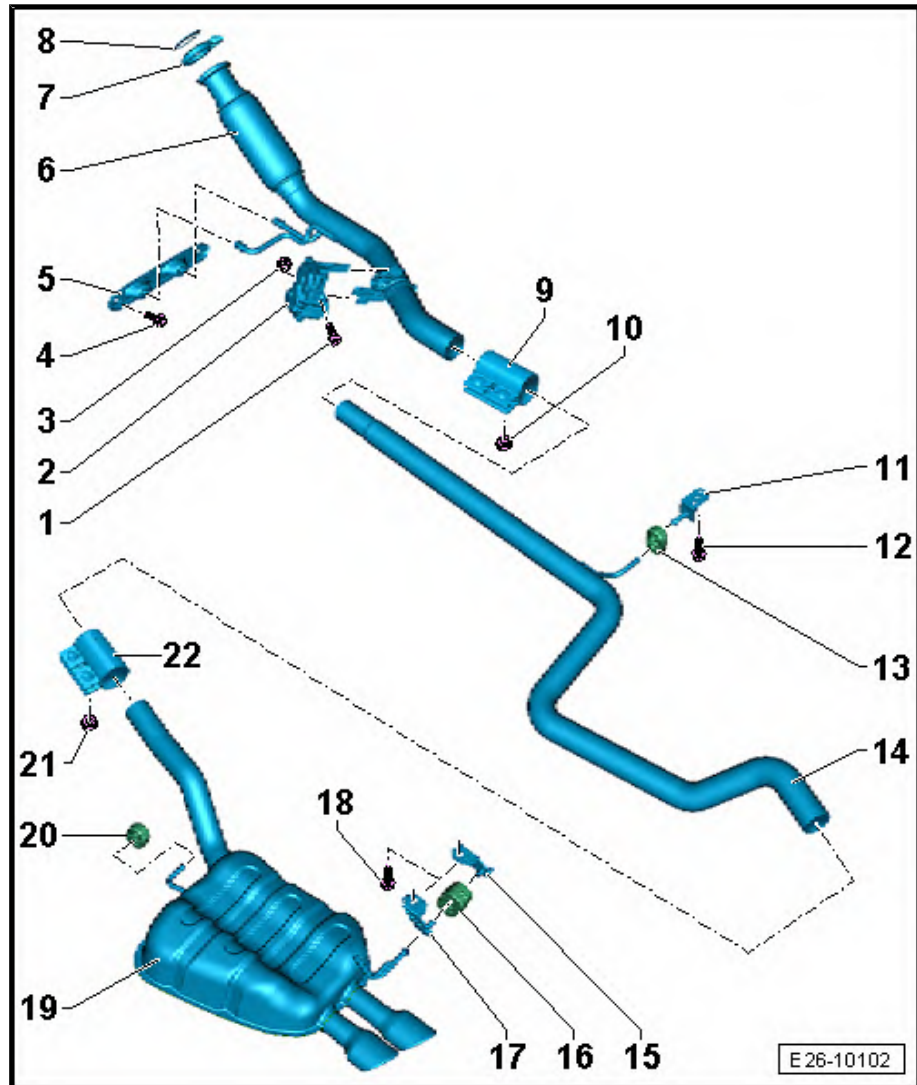

### 17 - Suspension element

- Renew if damaged.

### 18 - Bolt.

- 23 Nm

### 19 - Rear silencer

- Stress-free alignment of exhaust system ⇒ [page 383](#)
- Removing and fitting ⇒ [page 382](#)

### 20 - Mounting

- Renew if damaged.

### 21 - Nut

- Tightening torque ⇒ [page 376](#)

### 22 - Tension sleeve

- Before tightening, align exhaust system so it is free of stress ⇒ [page 383](#)
- Installation position ⇒ [page 373](#)
- Tighten bolted connections evenly

#### Installation position of screw-type clip for front exhaust pipe

- Square tab on seal -arrow- must fit into groove on diesel particulate filter.

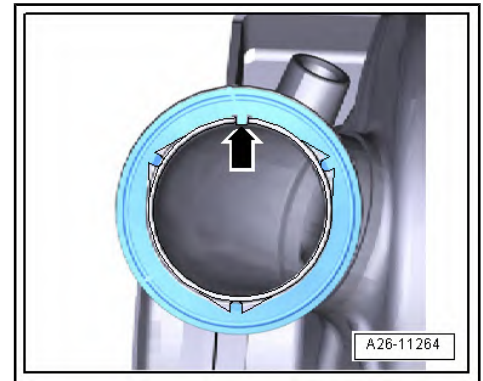

#### Installation position of screw-type clip for front exhaust pipe

- Fit the clamp at the angle shown.
- Angle  $\alpha$  = approx.  $50^\circ$ .
- Bolt connection facing towards right
- Nuts facing upwards

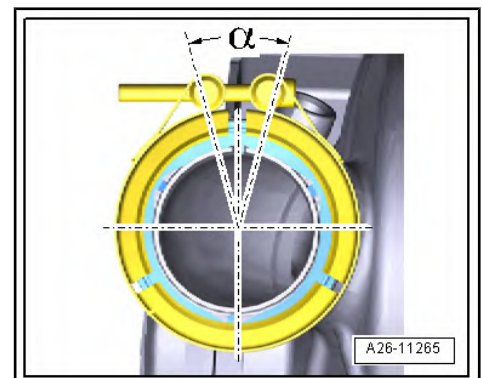

#### Installation position of front clamp

- Fit the clamp at the angle shown.
- Angle  $\alpha$  = approx.  $50^\circ$ .
- Bolt connection facing towards right
- Nuts facing upwards

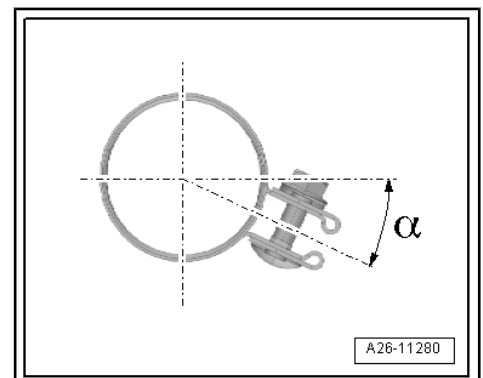

### Aligning mounting

- Pre-tighten bolt.
- Arrange hanger over the long hole bore
- Align holes -arrows- of mounting -A- centrally using blunt side of commercially available 8 mm drill bit.
- Then tighten to specified torque.
- Proceed in the same way with the remaining mountings.

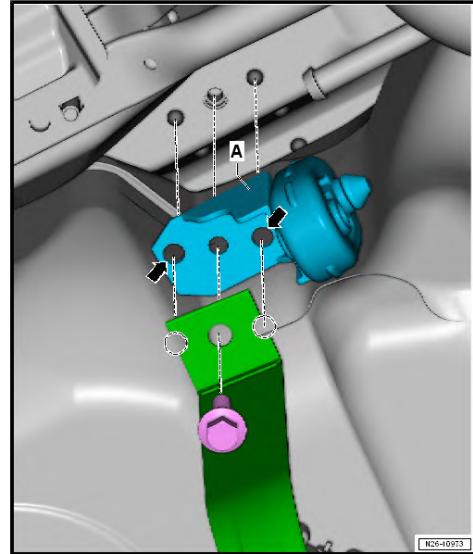

## 1.1.4 Installation overview - noise silencer, vehicle with four wheel drive and multi-link rear axle, León ST

- 1 - Bolt.
- 2 - Exhaust flap control unit - J883-
  - Removing and fitting ⇒ [page 410](#)
- 3 - Nut
  - 9 Nm
- 4 - Bolt.
  - 23 Nm
- 5 - Bracket/bearing/support
  - Renew if damaged.
- 6 - Front exhaust pipe
  - Removing and fitting ⇒ [page 378](#)
  - Stress-free alignment of exhaust system ⇒ [page 383](#)
- 7 - Screw-type clip
  - Renew following removal
  - Installation position ⇒ [page 375](#)
  - 7 Nm
- 8 - Seal
  - Renew following removal
  - Note installation position ⇒ [page 375](#).
- 9 - Tension sleeve
  - Before tightening, align exhaust system so it is free of stress ⇒ [page 383](#)

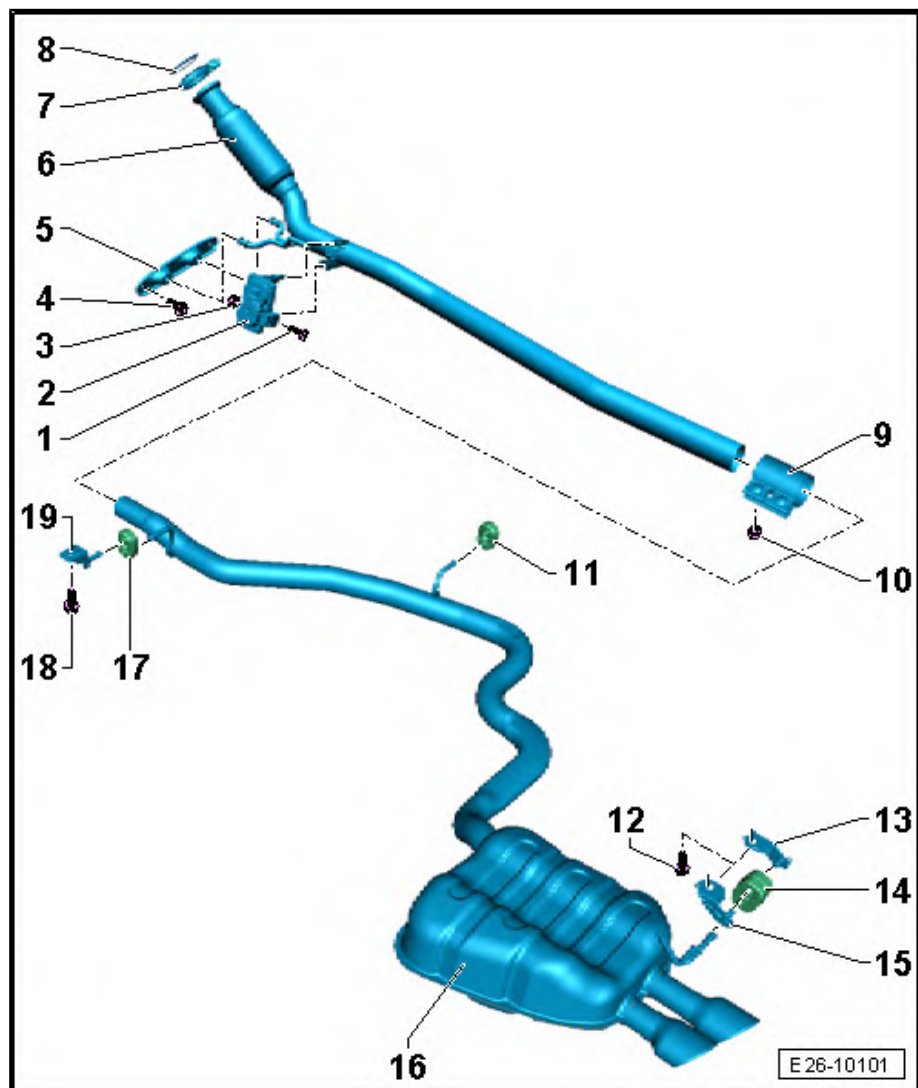

- Installation position ⇒ [page 376](#)
- Tighten bolted connections evenly

#### 10 - Nut

- Tightening torque ⇒ [page 376](#)

#### 11 - Holder

- Renew if damaged.

#### 12 - Bolt.

- 23 Nm

#### 13 - Suspension element

- Renew if damaged.

#### 14 - Mounting

- Renew if damaged.

#### 15 - Suspension element

- Renew if damaged.

#### 16 - Rear silencer

- Stress-free alignment of exhaust system ⇒ [page 383](#)
- Removing and fitting ⇒ [page 382](#)

#### 17 - Mounting

- Renew if damaged.

#### 18 - Bolt.

- 23 Nm

#### 19 - Suspension element

- Renew if damaged.

#### Installation position of screw-type clip for front exhaust pipe

- Square tab on seal -arrow- must fit into groove on diesel particulate filter.

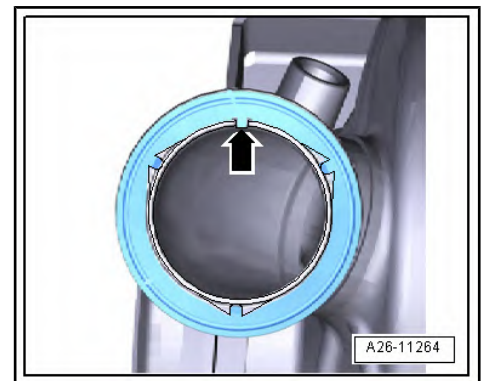

#### Installation position of screw-type clip for front exhaust pipe

- Fit the clamp at the angle shown.
- Angle  $\alpha$  = approx. 50°.
- Bolt connection facing towards right
- Nuts facing upwards

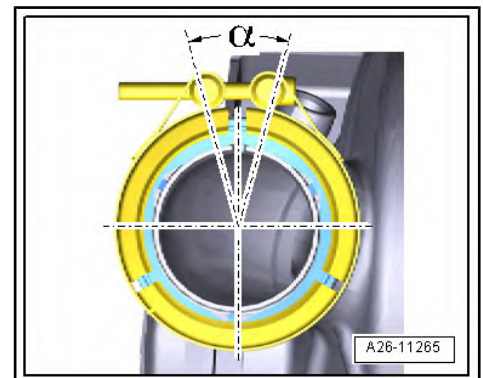

### Installation position of front clamp

- Fit the clamp at the angle shown.
- Angle  $\alpha$  = approx.  $50^\circ$ .
- Bolt connection facing towards right
- Nuts facing upwards

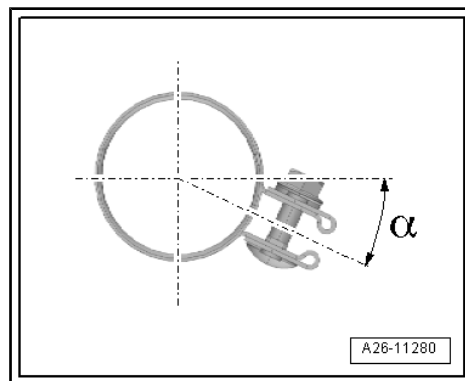

Installation dimension for vehicles with marking on the exhaust pipe

1 - Tension sleeve

2 - Exhaust pipe

a - Installation dimension

A - Marking on exhaust system

Installation dimension -a- for clamp:

a - 8.5 mm

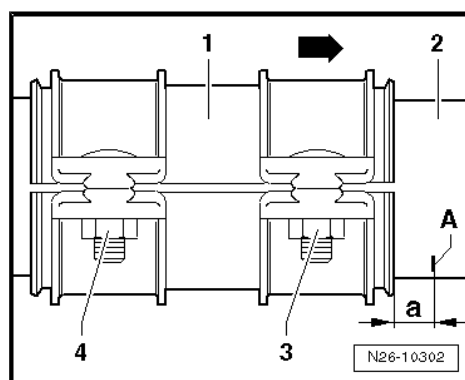

### Specified torque for clamp

Variante A - 25 Nm

Variante B - 30 Nm

Tighten threaded connections evenly.

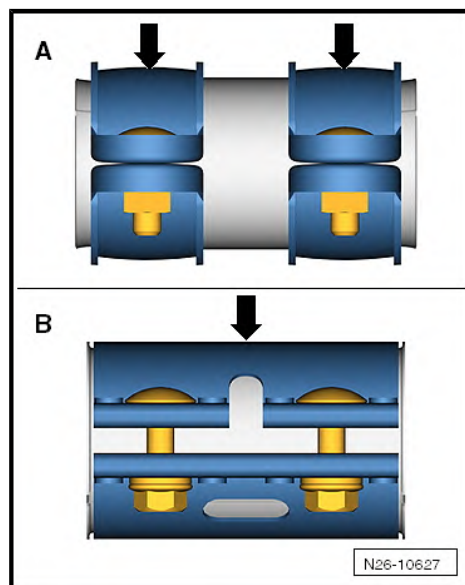

## 1.1.5 Installation overview - noise silencer, vehicles semi-rigid axle, León ST

Original equipment as single assembly together with rear silencer; to be renewed individually in event of repair

### 1 - Silencers, vehicles with 1.6 l engine

- Stress-free alignment of exhaust system  
 ⇒ [page 383](#)
- Disconnecting exhaust pipes/silencers  
 ⇒ [page 379](#)

### 2 - Mounting

- Replace if damaged

### 3 - Suspension element

- Replace if damaged

### 4 - Bolt.

- Aligning mounting  
 ⇒ [page 377](#)

- 20 Nm

### 5 - Bolt.

- 20 Nm

### 6 - Tension sleeve

- Align exhaust system so it is free of stress before tightening clamp  
 ⇒ [page 383](#)
- Tighten bolted connections evenly
- Installation position  
 ⇒ [page 368](#)
- Tightening torque  
 ⇒ [page 376](#)

### 7 - Noise silencer, vehicles with 2.0 litre engines

- Stress-free alignment of exhaust system ⇒ [page 383](#)
- Disconnecting exhaust pipes/silencers ⇒ [page 379](#)

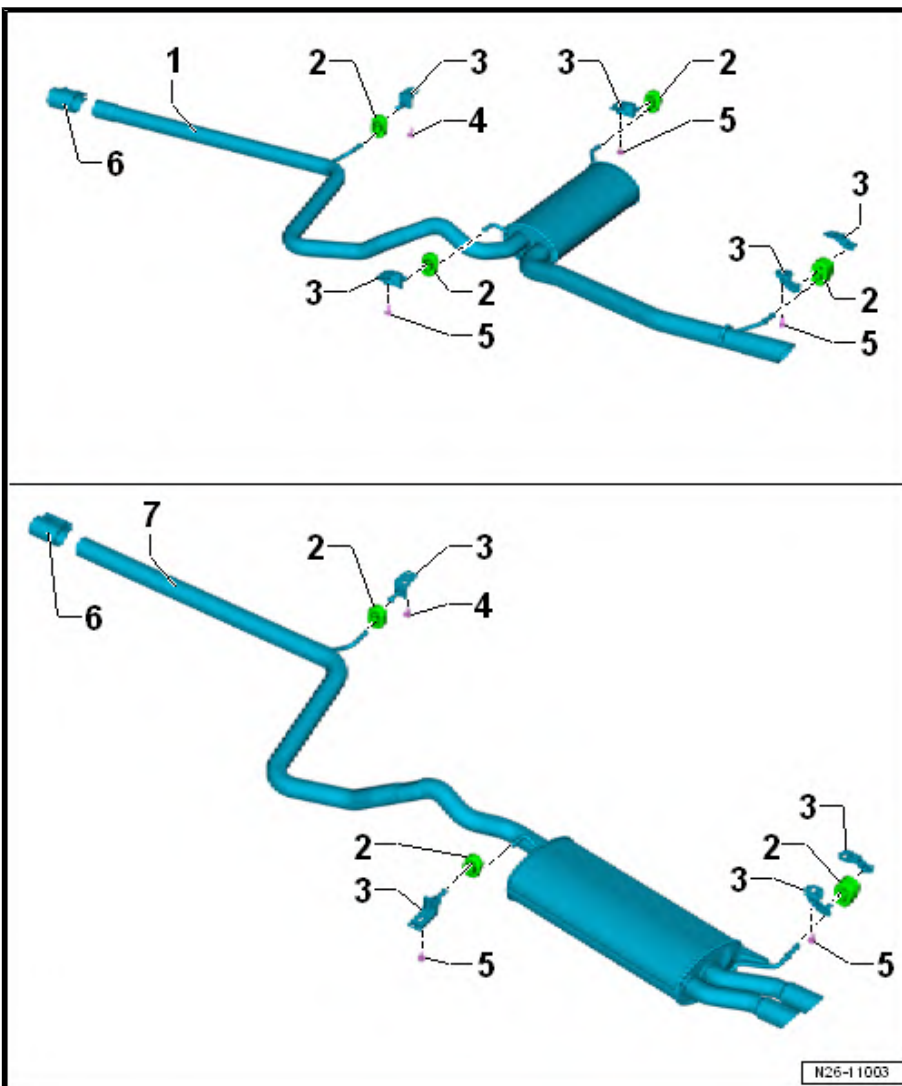

### Aligning mounting

- Pre-tighten bolt.
- Arrange hanger over the long hole bore
- Align holes -arrows- of mounting -A- centrally using blunt side of commercially available 8 mm drill bit.
- Then tighten to specified torque.
- Proceed in the same way with the remaining mountings.

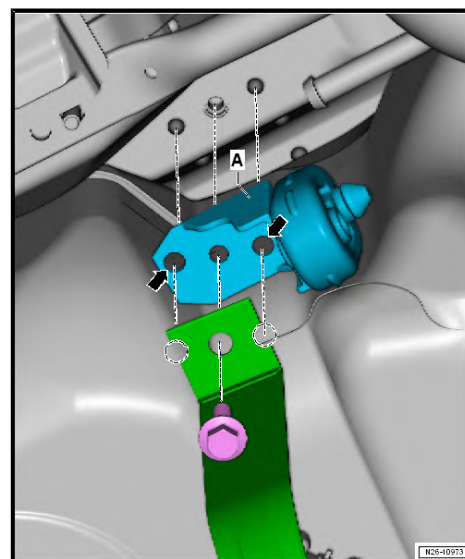

## 1.2 Removing and installing front exhaust pipe with catalytic converter

Special tools and workshop equipment required

- ◆ Transport lock - T10404-

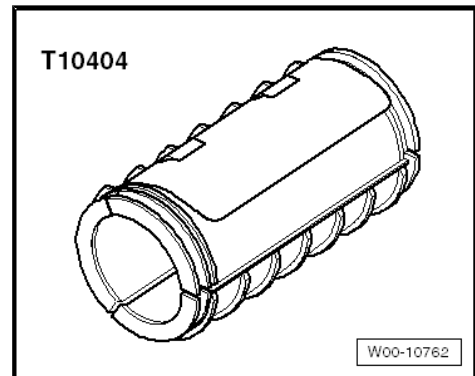

### Removal



#### Note

- ◆ *The flexible joint in the front exhaust pipe must not be bent more than 10° - otherwise it can be damaged.*
- ◆ *To re-install the front exhaust pipe, fit the transport lock - T10404- -arrow- on damping element on the front section of the exhaust pipe.*

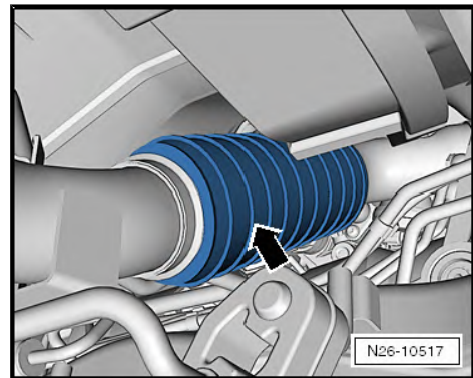

### Vehicles with exhaust flap control unit - J883- :

- If fitted, remove heat insulation sleeve from connector.
- Unplug the electrical connector -1-.

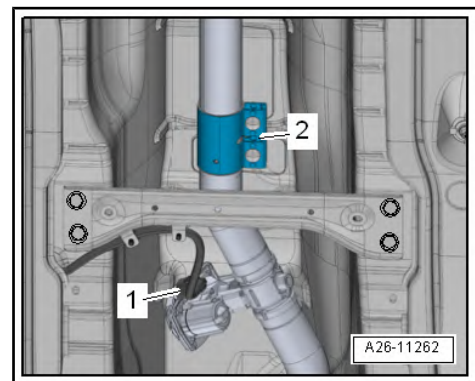

**All vehicles (continued):**

- Release the tightening clamp -2- and move it backwards.
- Remove screws -1-.
- Slacken bolt -2- and remove clip.
- Remove the exhaust primary tube.

**Installation**

Installation is carried out in the reverse order; note the following:



*Seal must be renewed if removed*

- Note installation position:
  - ⇒ [Fig. “Installation position of screw-type clip for front exhaust pipe”](#), page 368
  - ⇒ [Fig. “Installation position of seal between emission control module and exhaust pipe”](#), page 368
  - ⇒ [Fig. “Installation position of the clamping sleeve”](#), page 368
- Align exhaust system without tension ⇒ [page 383](#) .

**Specified torques**

- ◆ ⇒ [“1.1 Exploded view - silencers”](#), page 366

**1.3 Disconnecting exhaust pipes/silencers**

⇒ [“1.3.1 Disconnecting exhaust pipes/silencers, Leon 2013”](#), page 379

⇒ [“1.3.2 Disconnecting exhaust pipes/silencers, Leon ST”](#), page 380

**1.3.1 Disconnecting exhaust pipes/silencers, Leon 2013**

- ◆ Original equipment as single assembly together with rear silencer; to be renewed individually in event of repair
- ◆ The connecting pipe can be cut through at the cutting point in order to renew the centre and rear silencers separately.
- ◆ The cutting point is marked on the exhaust tube.
- ◆ The cutting point is located in the area of the rear axle.

**Special tools and workshop equipment required**

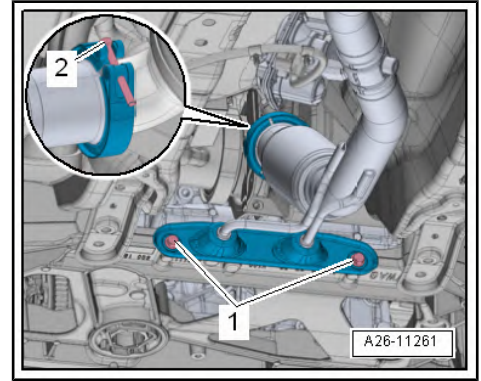

- ◆ Chain-type pipe cutter - VAS 6254-

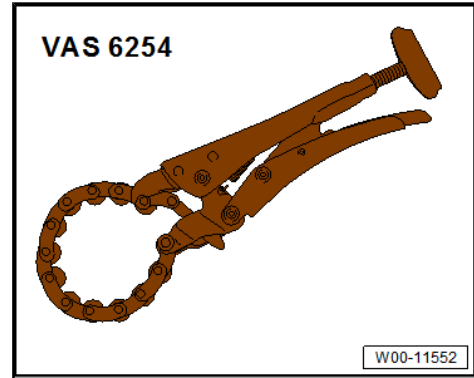

- ◆ Pneumatic sabre saw - V.A.G 1523B-

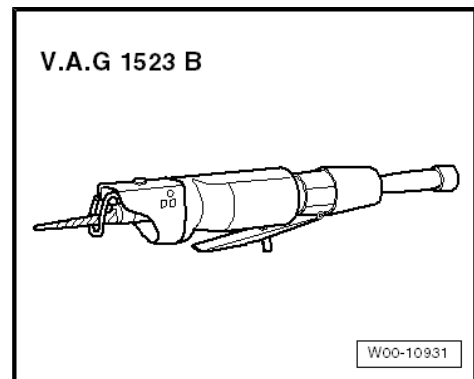

### Operation process

- Cut through the exhaust pipe at a right angle at the position marked -arrow- using chain pipe cutter - VAS 6254- .

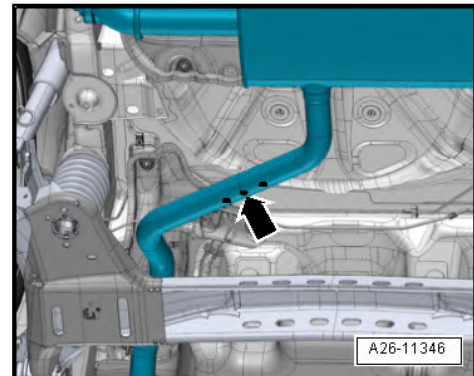

- Position clamp centrally at side marks -arrows- when installing.
- Fit clamp at rear.
- Align exhaust system without tension  
⇒ ["1.5 Align exhaust system to be free of stress", page 383](#) .

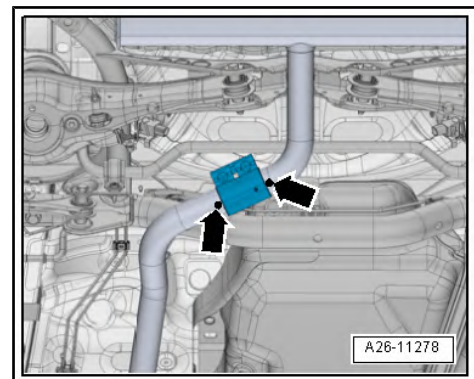

## 1.3.2 Disconnecting exhaust pipes/silencers, León ST

- ◆ Original equipment as single assembly together with rear silencer; to be renewed individually in event of repair
- ◆ The connecting pipe can be cut through at the cutting point in order to renew the centre and rear silencers separately.

- ◆ The cutting point is marked on the exhaust tube.
- ◆ The cutting point is located in the area of the rear axle.

#### Special tools and workshop equipment required

- ◆ Chain-type pipe cutter - VAS 6254-

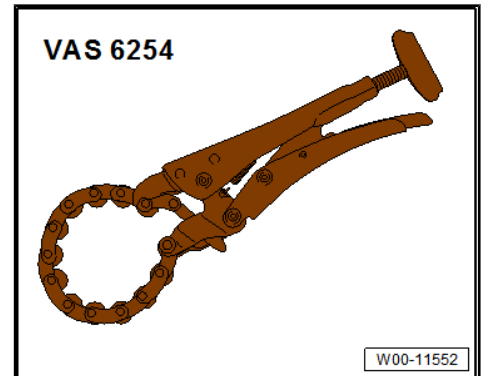

#### Operation process

- Cut through the exhaust pipe at a right angle at the position marked -arrow- using chain pipe cutter - VAS 6254- .

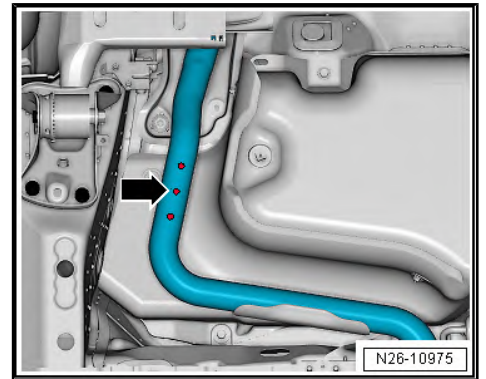

- When installing, position clamp centrally (-dimension a-) between side marks -arrows-.
- Fit clamp at rear.
- Align exhaust system without tension  
⇒ ["1.5 Align exhaust system to be free of stress", page 383](#) .

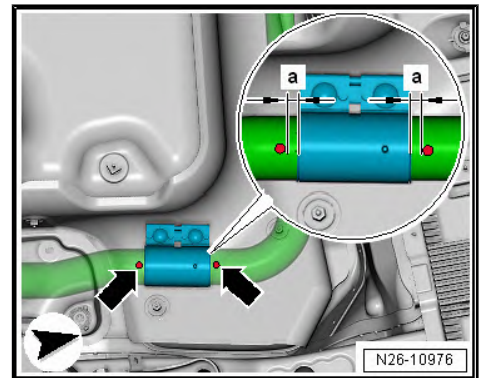

## 1.4 Removing and installing rear silencer

⇒ [“1.4.1 Remove and install rear exhaust silencer, Leon 2013”, page 382](#)

⇒ [“1.4.2 Remove and install rear exhaust silencer, Leon ST”, page 383](#)

### 1.4.1 Remove and install rear exhaust silencer, Leon 2013



#### Note

- ◆ *Implemented ex factory with centre silencer as one component; to be renewed individually in the event of a repair*
- ◆ *Observe separation line -A- ⇒ [page 379](#) .*

#### Special tools and workshop equipment required

- ◆ Engine elevator - VAS 6931-



#### Removing

- Loosen clamp -arrow- and push towards rear.
- Hold silencer with engine and gearbox jack - VAS 6931- .
- Unscrew bolts -1- from the body. Remove silencer -2-.

#### Installation

Installation is carried out in the reverse order; note the following.

- Align exhaust system without tension ⇒ [page 383](#) .

#### Specified torques

- ◆ ⇒ [“1.1.1 Installation overview - noise silencer, vehicle with front wheel drive and multi-link rear axle”, page 366](#)

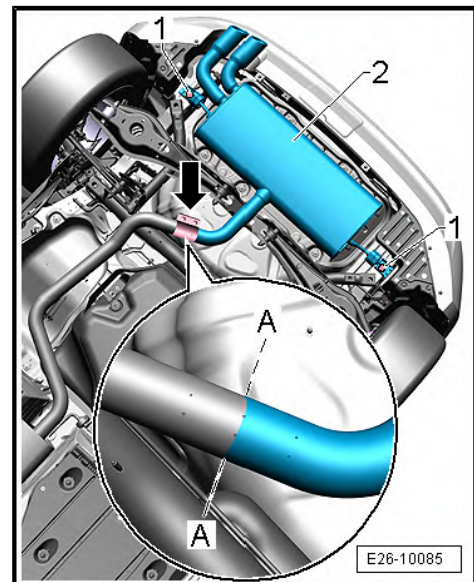

## 1.4.2 Remove and install rear exhaust silencer, León ST

### Note

- ◆ Implemented ex factory with centre silencer as one component; to be renewed individually in the event of a repair
- ◆ Observe separation line -A- ⇒ [page 379](#) .

### Special tools and workshop equipment required

- ◆ Engine elevator - VAS 6931-



### Removal

- Detach mounting -1- from the silencer.
- Loosen clamp -arrow- and push towards rear.
- Hold silencer with engine and gearbox jack - VAS 6931- .
- Unscrew bolt -2- from the body. Remove silencer -3-.

### Installation

Installation is carried out in the reverse order; note the following.

- Align exhaust system without tension ⇒ [page 383](#) .

### Specified torques

- ◆ ⇒ [“1.1.3 Installation overview - noise silencer, vehicle with front wheel drive and multi-link rear axle, León ST”, page 371](#)

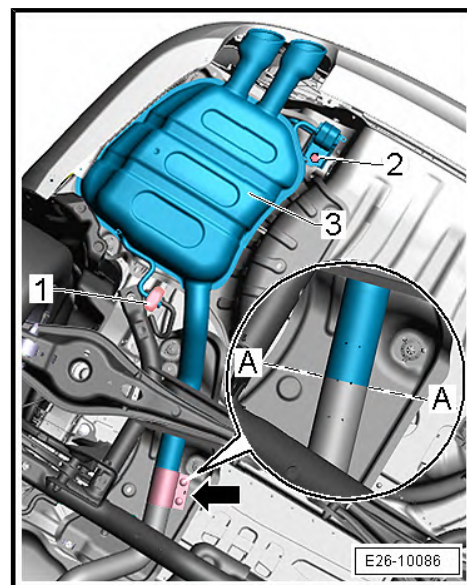

## 1.5 Align exhaust system to be free of stress

### Operation process

- The exhaust system must be aligned when it is cool.

- Loosen bolt connections for clamp -2-.

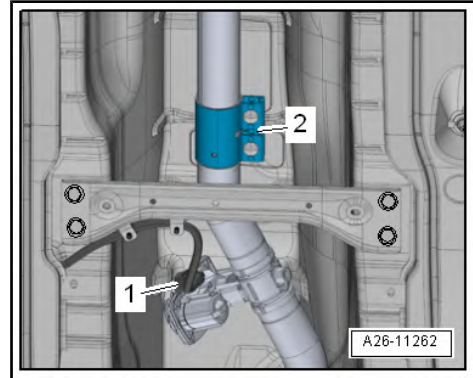

- Push exhaust system towards front of vehicle until preloading at mounting for exhaust pipe -a- = 5 mm.

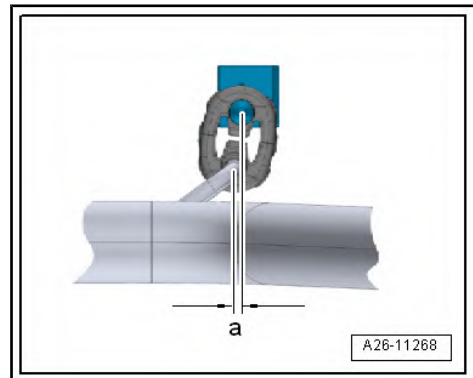

- Fit the clamp at the angle shown.
- Fit the clamp at the angle shown.
- Angle - $\alpha$ - = approx. 20°.
- Bolt connection facing towards right
- Nuts facing upwards
- Tighten bolt connections on clamp evenly.

⇒ ["1.1 Exploded view - silencers", page 366](#) .

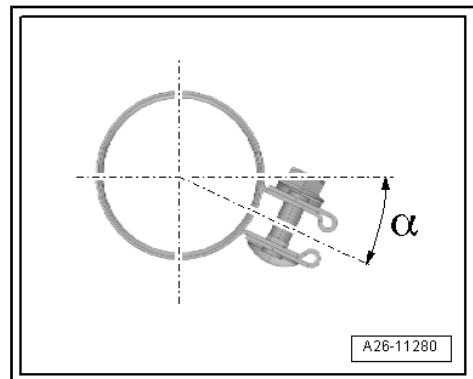

## 1.6 Check exhaust system for leaks

- Start engine and run at idling speed.
- Plug tailpipes during leak test (e.g. with cloth or plugs).
- Listen for noise at the connection points of cylinder head/exhaust manifold, turbocharger/front exhaust pipe etc. to locate any leaks.
- Rectify any leaks that are found.

## 2 Emission control

⇒ [“2.1 Assembly overview - emission control”, page 385](#)

⇒ [“2.2 Removing and installing catalytic converter”, page 388](#)

⇒ [“2.3 Removing and installing particulate filter”, page 389](#)

⇒ [“2.4 Removing and installing emission control module”, page 390](#)

⇒ [“2.5 Removing and installing exhaust flap control unit J883”, page 410](#)

### 2.1 Assembly overview - emission control

⇒ [“2.1.1 Assembly overview - emission control”, page 385](#)

⇒ [“2.1.2 Assembly overview – emission control system, engine codes CRVA, CRVC, CRGA”, page 387](#)

#### 2.1.1 Assembly overview - emission control

##### 1 - Front exhaust pipe

- Removing and fitting  
⇒ [page 378](#)
- Stress-free alignment of  
exhaust system  
⇒ [page 383](#)

##### 2 - Screw-type clip

- Renew following removal
- Installation position  
⇒ [page 368](#)
- Tightening torque  
⇒ [Item 10 \(page 367\)](#)

##### 3 - Seal

- Note installation position  
⇒ [page 368](#) .

##### 4 - Bolt.

- Tightening torque and  
sequence ⇒ [page 398](#) .

##### 5 - Seal

##### 6 - Screw-type clip

- Installation position  
⇒ [page 422](#)
- Tightening torque and  
sequence ⇒ [page 422](#) .

##### 7 - Exhaust gas recirculation cooler

- Removing and fitting  
⇒ [page 425](#)

##### 8 - Bolt.

- Tightening torque and  
sequence ⇒ [page 422](#) .

##### 9 - Bolt.

- Tightening torque and sequence ⇒ [page 422](#) .

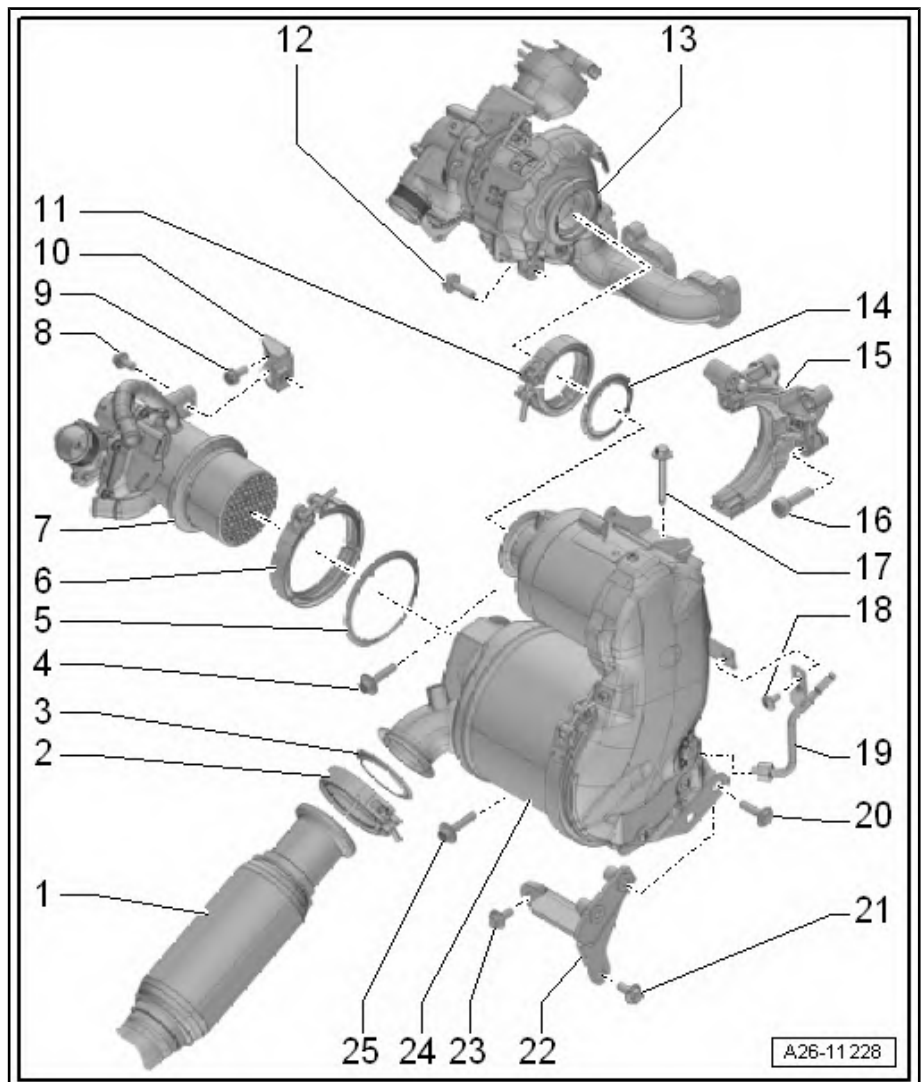

**10 - Bracket/bearing/support**

- for the exhaust gas recirculation cooler

**11 - Screw-type clip**

- Tightening torque and sequence ⇒ [page 398](#) .

**12 - Bolt.**

- Tightening torque and sequence ⇒ [page 253](#) .

**13 - Exhaust turbocharger**

- Removing and fitting ⇒ [page 254](#)

**14 - Seal**

- Fit on catalytic converter

**15 - Bracket/bearing/support**

- For emission control module
- With compensation element
- Preparing compensation element for fitting ⇒ [page 397](#)

**16 - Bolt.**

Tightening torque and sequence ⇒ [page 253](#) .

**17 - Bolt.**

- Tightening torque and sequence ⇒ [page 398](#) .

**18 - Bolt.**

- 9 Nm

**19 - Measuring tube**

- To pressure differential sender - G505-
- Tightening torque of union nut: 45 Nm

**20 - Bolt.**

- Tightening torque and sequence ⇒ [page 387](#) .

**21 - Bolt.**

- Tightening torque and sequence ⇒ [page 387](#) .

**22 - Bracket/bearing/support**

- For emission control module
- With compensation elements
- Preparing compensation elements for fitting ⇒ [page 407](#)

**23 - Bolt.**

- Tightening torque and sequence ⇒ [page 387](#) .

**24 - Emission control module**

- Diesel particulate filter with catalytic converter
- Removing and fitting ⇒ [page 390](#)

**25 - Bolt.**

- Tightening torque and sequence ⇒ [page 398](#) .

**Bracket -2- for emission control module - tightening torque and tightening sequence**

– Tighten bolts in stages in the sequence given:

stage	Bolts	Tightening torque
1st	-3-	Screw in by hand until they make contact
2nd	-1-	20 Nm
3.	-3-	20 Nm

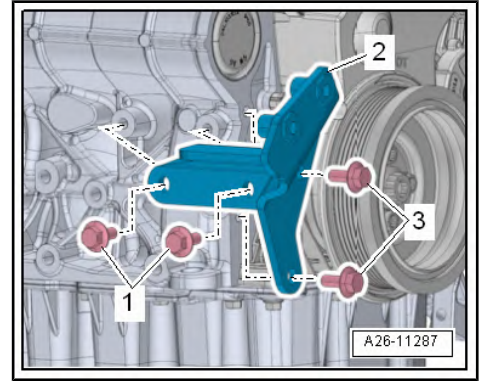

**2.1.2 Assembly overview – emission control system, engine codes CRVA, CRVC, CRGA**

**1 - Bolt.**

- Tightening torque and sequence => [page 389](#) .

**2 - Bracket/bearing/support**

- Not always installed.
- bolted to the cylinder head
- Tightening torque and sequence => [page 389](#) .

**3 - Catalytic converter/particulate filter**

- Versions for specific countries
- Removing and fitting => [page 388](#)

**4 - Bolt.**

- Tightening torque and sequence => [page 389](#) .

**5 - Seal**

- Renew following removal

**6 - Screw-type clip**

- Tightening torque and sequence => [page 389](#) .

**7 - Seal**

- Renew following removal

**8 - Front exhaust pipe**

**9 - Bolt.**

- Tightening torque and sequence => [page 389](#) .

**10 - Nut**

- Tightening torque and sequence => [page 389](#) .

**11 - Bracket/bearing/support**

- bolted to the crankcase
- Tightening torque and sequence => [page 389](#) .

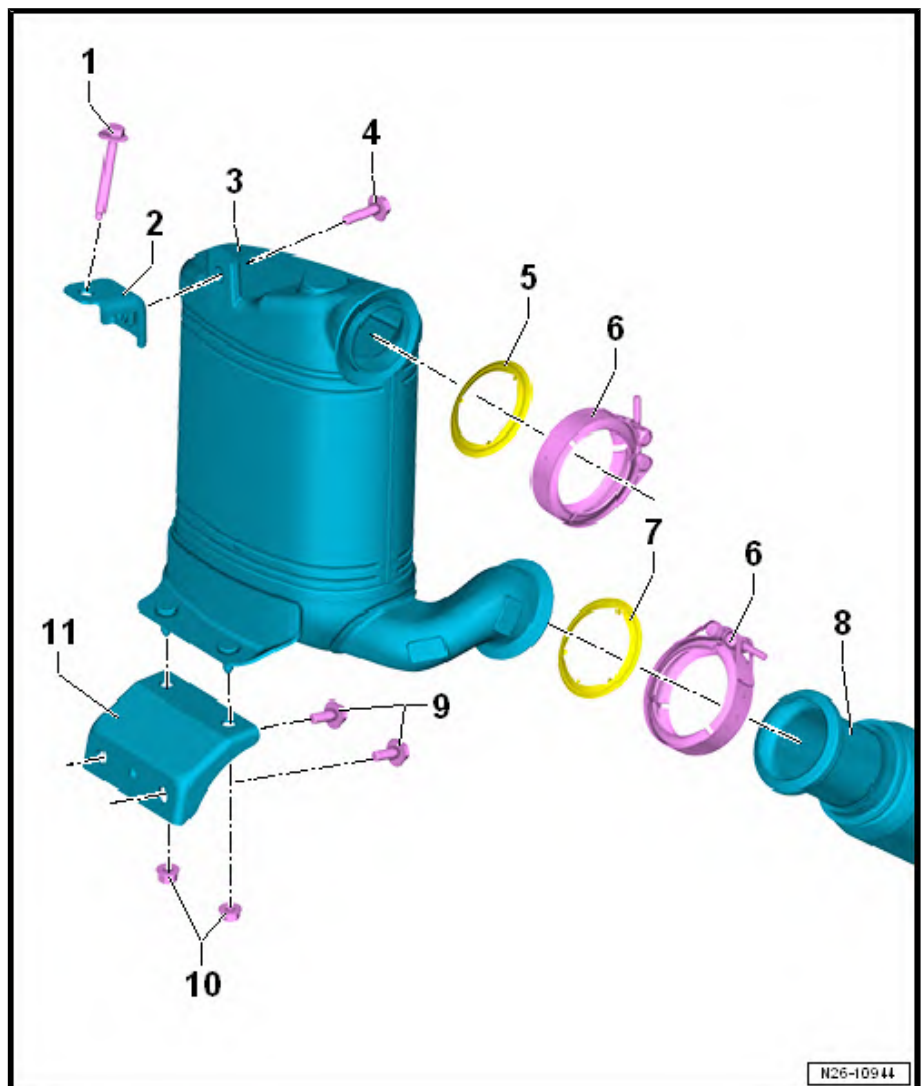

## 2.2 Removing and installing catalytic converter



### Note

*Depending on national emission thresholds an uncontrolled particle filter or catalytic converter is fitted with this engine. The difference for removal or installation is negligible. For this reason, only the removal of the catalytic converter is described.*

### Removal

- Remove noise insulation => General body repairs, exterior; Rep. gr. 66 ; Noise insulation; Removing and installing noise insulation .
  - Unscrew the bolts of the clamp -2- leaving the clamp in installation position.
  - Open clamp -1- and detach.
  - Remove the bolts -3- push the clamp -2- backwards and remove the front exhaust pipe -A-.
- 
- Detach fastening nuts -1- and loosen bolts -2- by one quarter turn.
  - Remove engine cover. => [page 56](#)
  - Unscrew bolts -arrows- of the coolant line and pull the coolant line forwards.

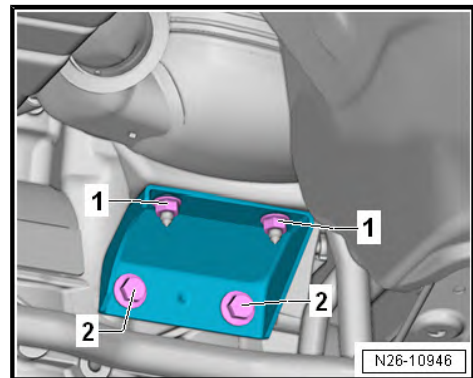
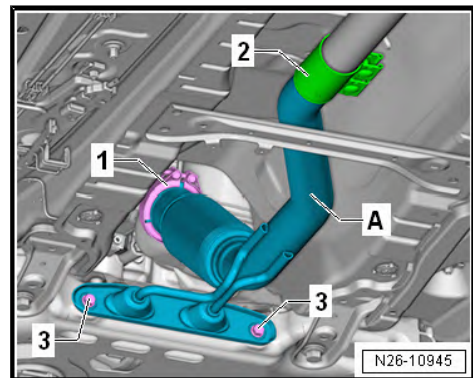

- Unscrew bolts -1- and -3- open clamp -2- and remove.
- Carefully remove catalytic converter upwards.

**Installation**

**i Note**

- ◆ *Renew self-locking nuts and bolts as well as gaskets, seals and O-rings after each removal.*
- ◆ *Secure all hose connections with the correct type of hose clips (same as original equipment) ⇒ Electronic parts catalogue .*
- ◆ *When fitting, attach all cable ties back to the same location.*

- Push new seal onto the centring supports of the inlet funnel on the catalytic converter and push a new clamp over the inlet funnel.
- Fit the catalytic converter from above into the lower mounting with the threaded studs.
- Subsequent tightening sequence as per the following table  
⇒ [page 389](#)

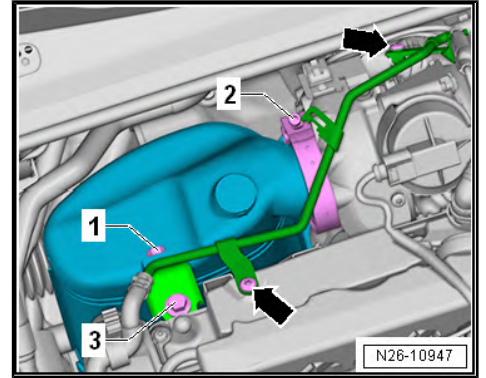

**Tightening torques and sequence for catalytic converter**

stage	Bolt.	Measure
I	Screw-type clip -1-	position over the sealing flange, engage bolt
II	Bolts -2 and 3-	Tighten by hand and loosen immediately by 90°
III	Screw-type clip -1-	tighten to 8 Nm
IV	Nuts -4-	tighten to 20 Nm
V	Bolts -5-	tighten to 20 Nm
VI	Bolt -2-	tighten with 20 Nm , turn another 90° and subsequently turn another 45°
VII	Bolt -3-	tighten to 20 Nm

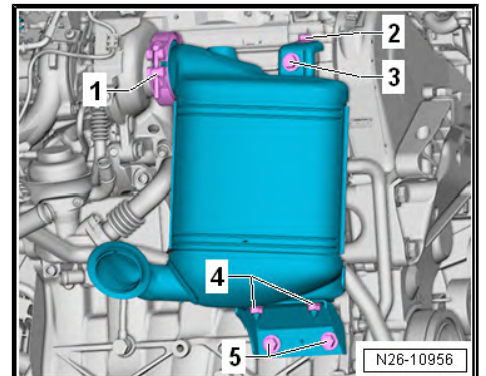

Further assembly in reverse order of removal.

**2.3 Removing and installing particulate filter**

**i Note**

*Depending on national emission thresholds an uncontrolled particulate filter or catalytic converter is fitted with this engine. The difference for removal or installation is negligible. For this reason, only the removal of the catalytic converter is described ⇒ [page 388](#) .*

## 2.4 Removing and installing emission control module

⇒ ["2.4.1 Remove and install emission control module, vehicles with front wheel drive", page 390](#)

⇒ ["2.4.2 Remove and install emission control module, vehicles with four wheel drive", page 400](#)

### 2.4.1 Remove and install emission control module, vehicles with front wheel drive



#### Note

Amongst others, the emission control module is fixed to the engine with 4 compensation elements. These compensation elements have a left-hand thread on the outside. When the bolt -1- is screwed in, the friction against the retainer tabs -3- initially causes the compensation element -2- to turn as well. Even though the bolt is turned clockwise, the left-hand thread causes the compensation element to move towards the bolt head, which compensates for the play between the components. The compensation element must rotate freely on the left-hand thread, otherwise the retainer tabs will not produce enough friction on the bolt to turn the compensation element. To avoid impairing the required friction, ensure that the retainer tabs do not come in contact with any lubricant.

#### Function of compensation element

#### Special tools and workshop equipment required

◆ Assembly tool - T10511-

◆ Calibration tool - T10512-

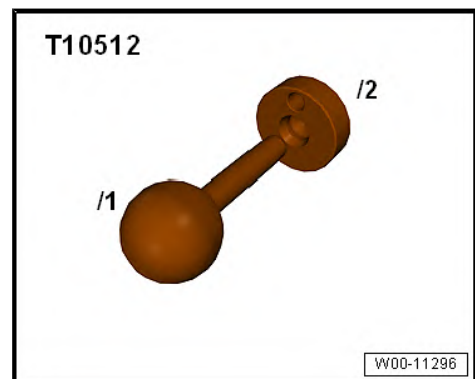
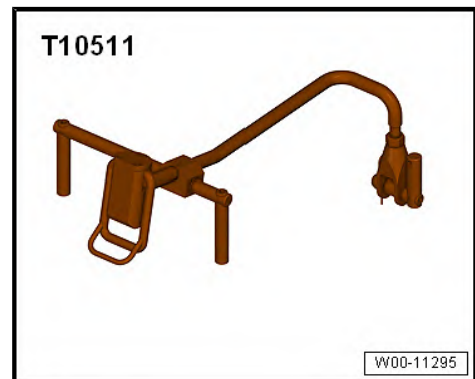
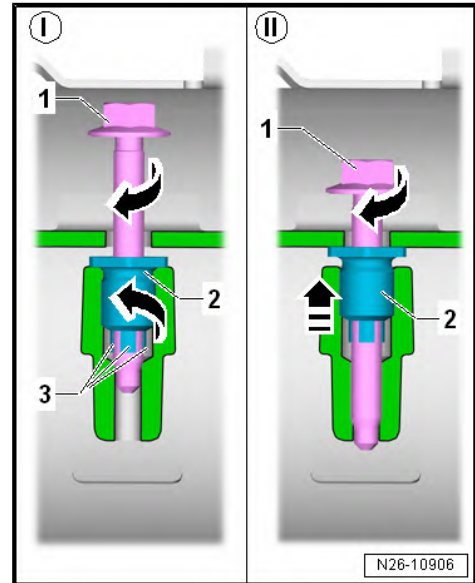

- ◆ Socket 8 mm - 3247-



- ◆ Engine support - T10533-



### Removal

- Remove exhaust temperature sender 3 - G495-  
 ⇒ [page 411](#) .
- Remove exhaust temperature sender 2 - G448-  
 ⇒ [page 411](#) .
- Remove exhaust temperature sender 4 - G648-  
 ⇒ [page 411](#) .
- Remove lambda probe 1 before catalytic converter - GX10-  
 ⇒ [page 362](#) .
- If fitted, remove lambda probe 1 after catalytic converter -  
 GX7- ⇒ [page 363](#) .
- Press the release buttons on the crankcase breather hose  
 -1- and remove it from the cylinder head cover.
- Unscrew bolt -3-, swing air pipe with inlet connection -2- to rear  
 and pull off from turbocharger.

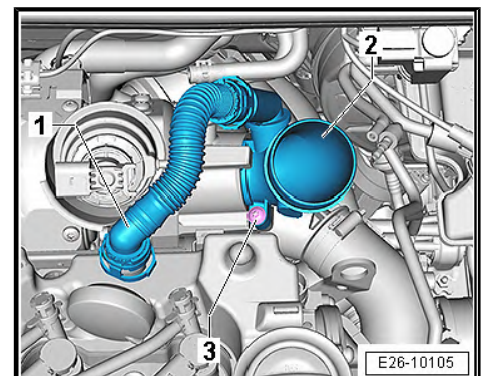

- Loosen the clamp -1-, remove the screws -arrows-, and separate the air hose with the resonator-2-.

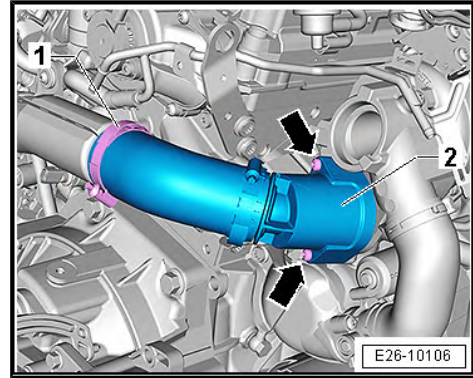

- Using a screwdriver, release fasteners -arrow- and move coolant expansion tank to one side.

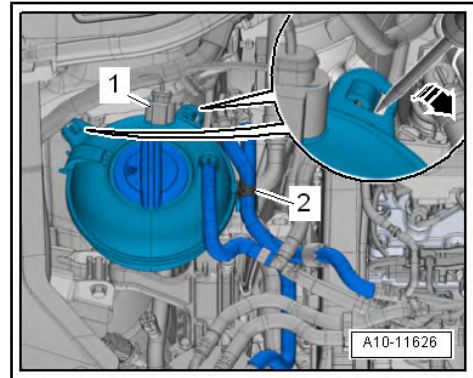

#### Vehicles with pressure differential sender - G505-

- Open heat insulation sleeve -1-.
- Take electrical connector -4- out of bracket, unplug it and move electrical wiring clear.
- Unplug electrical connectors -3, 5- and move electrical wiring harness clear.
- Remove bolt -2- and move bracket with pressure differential sender - G505- towards rear.

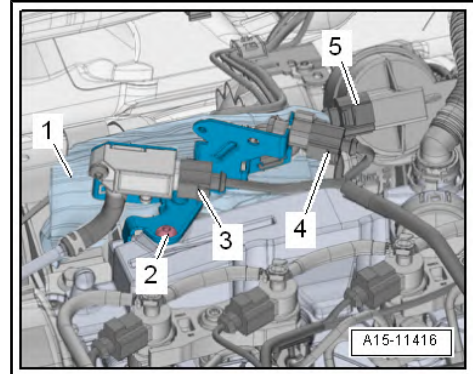

- Remove bolt -arrows-.
- Release clip -A-, disconnect hose, unclip pipe -B- and detach together with pressure differential sender - G505- .

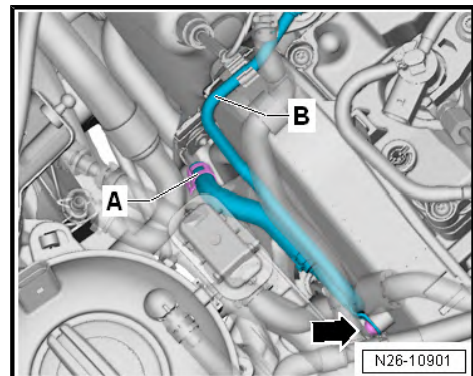

**Vehicles with pressure differential sender - G505- and pressure sensor 1 for exhaust - G450-**

- Open heat insulation sleeve -1-.
- Take electrical connector -5- out of bracket, unplug it and move electrical wiring clear.
- Disconnect electrical connectors -3, 4 and 6- and move wiring harness clear.
- Unscrew the bolt -2-.

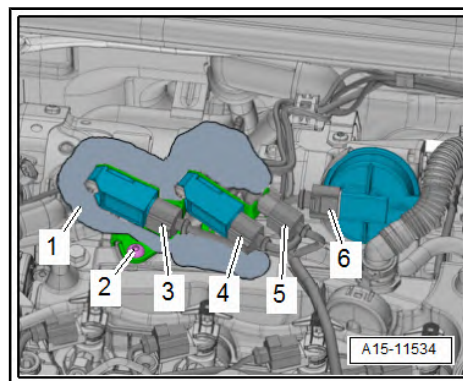

- Unscrew the bolt -3-.
- Undo the hose clips -1- and remove the hoses.
- Unhook pipe line -2- and remove with the pressure differential senders.

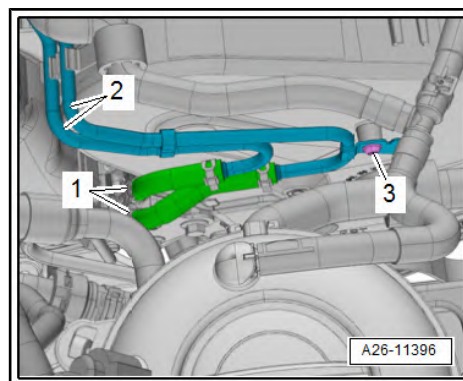

**All vehicles (continued):**

- Open clamp -1- and pull coolant hose.
- Remove bolts -2- and -3- and pivot coolant pipe clear to one side.

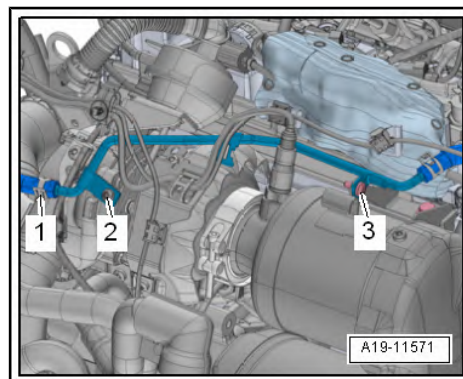

**All vehicles (continued):**

- Remove bolt -arrows-.



**Note**

*The feet of the assembly tool - T10511- rest on the bolt heads in the cylinder head cover.*

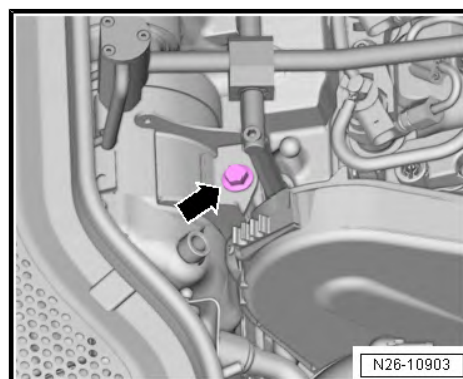

- Set up assembly aid - T10511- as shown and engage retainer -arrow- in bracket of emission control module.

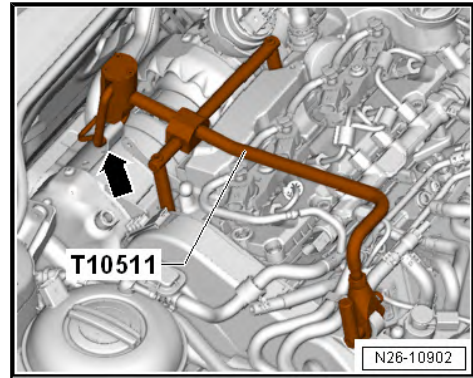

- Open clip -1- and place it on intake funnel of emission control module.



**Note**

*Disregard -items 2, 3 and 4-.*

- Drain coolant ⇒ [page 181](#) .
- Remove the rear coolant pipe ⇒ [page 217](#) .

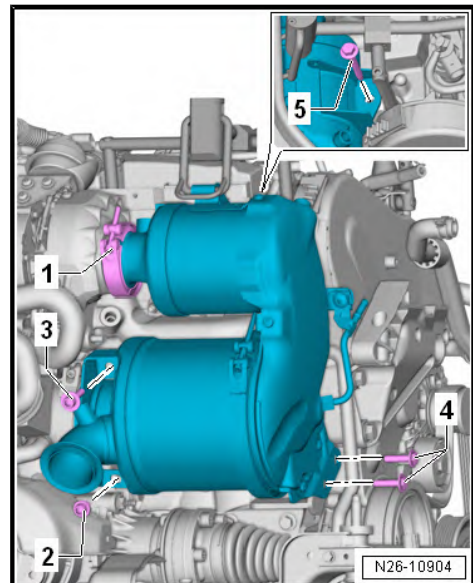

- Release and unplug electrical connector -1-.
- Release hose clips and remove coolant hoses -arrows- from the auxiliary heating pump - V488- -2-.
- Unscrew the bolt -3-.
- Remove the auxiliary pump for heating - V488- -2- together with the bracket.

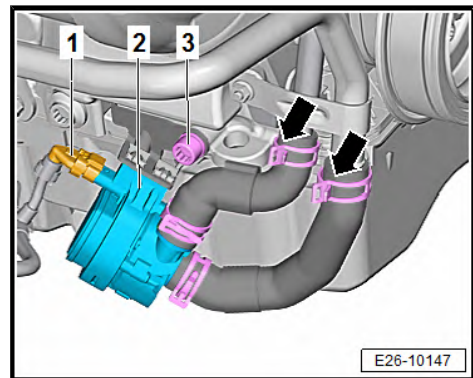

- Unplug electrical connector -arrow- at oil level and oil temperature sender - G266- .

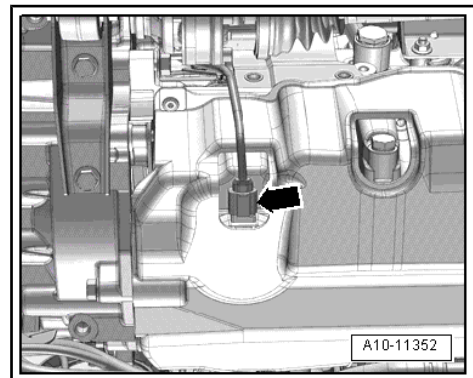

- If installed, remove bolts -1- and the heat guard.
- Remove the right-hand drive shaft from the flange shaft / from the gearbox ⇒ Rep. gr. 40 ; Drive shaft; Assembly overview  
 - Drive shaft and tie it up to the rear.
- Remove front exhaust pipe ⇒ [page 378](#) .

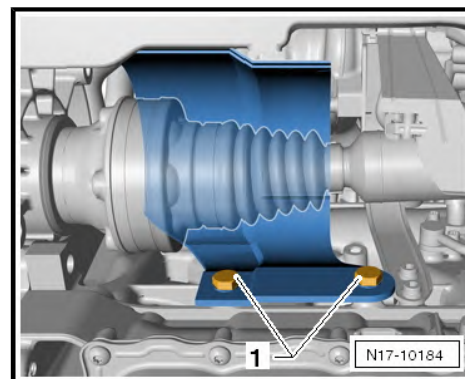

- Remove bolts -1, 2, 3- and detach pendulum support.

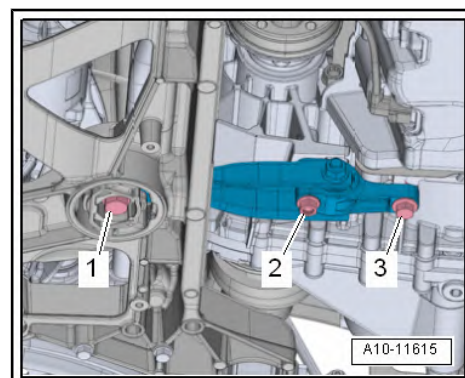

- Fit engine support - T10533- as shown in illustration, and tighten bolts by hand. Bolt -1- = original bolt for pendulum support.
- Push engine and gearbox as far as possible towards front by turning spindle. Avoid collisions with other components.

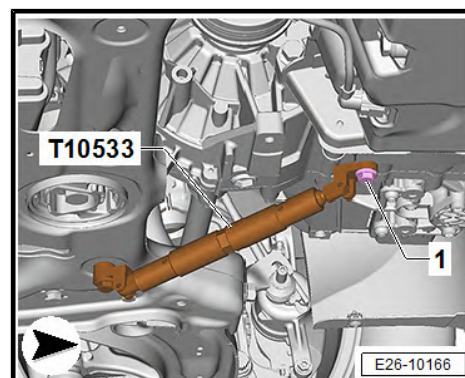

- Push heat insulation sleeve to one side and unplug electrical connector -5-.
- Loosen the hose clip -3-, remove the air intake hose.
- Loosen bolt -6- and push screw-type clip towards particulate filter.
- Remove bolt -2- using the XZN 10 - T10501- .

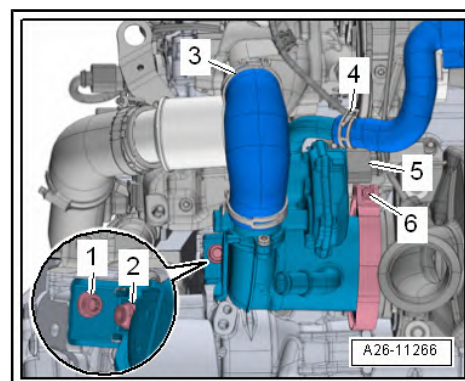

- Remove screws -4-.
- Remove bolts -5, 6- using the XZN 10 - T10501- .
- Pull down the mechanism of the assembly tool - T10511- in the direction of the arrow -2- in order to release the bracket from the tab on the emission control module

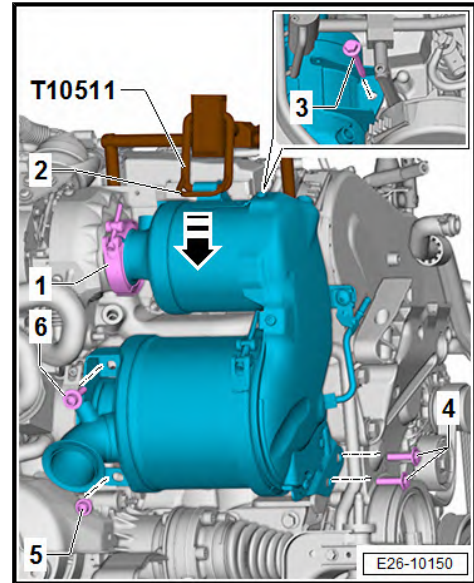

- Separate the exhaust gas recirculation cooler -1- from the emission control module -2- -arrows-, support the cooler on the left side.

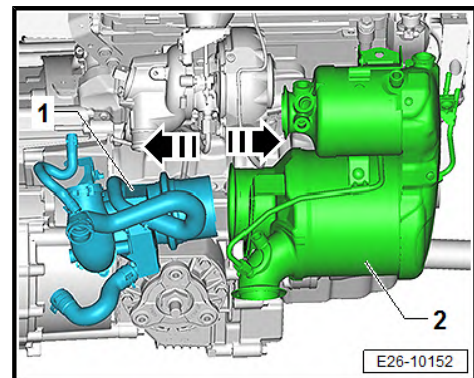

- Move the exhaust treatment module -1- down.

### Installation

- Assembly aid - T10511- set up on engine

### Note

- ◆ *Ensure that the retaining bar of the assembly tool - T10511- is »opened« towards plenum chamber bulkhead.*
- ◆ *Renew gaskets, self-locking nuts and screw-type clamp for emission control module after removal.*
- ◆ *Fit all cable ties and heat insulation sleeves in the original positions when installing.*

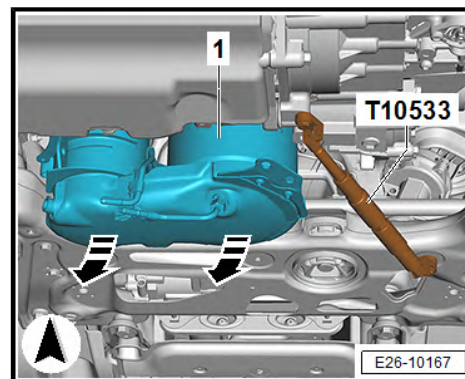

### Caution

***Emission control module must be installed free of tension to avoid risk of stress fractures and engine damage.***

- ◆ *Prior to installation, ensure that the compensation elements move easily and do not stick.*
- ◆ *Compensation element must turn easily on its threads.*
- ◆ *Only apply lubricant to thread; retainer tabs must remain »clean«.*
- ◆ *The retainer tabs for the bolt must be bent together so that when the bolt is screwed in, the compensation element turns as well.*

- Check that compensation elements -arrow- are free to move.
- Unscrew compensation elements completely in clockwise direction (left-hand thread).
- Clean any threads that do not turn easily and lubricate lightly with rust remover if necessary.



### Caution

***Ensure that no lubricant gets on the retainer tabs of the compensation elements. If the friction is reduced, functional impairment of the compensation elements will be the result.***

- Adjust retainer tabs to functional dimension using calibration tool - T10512- as follows:
- Slide compensation element onto pin, insert into centring sleeve and bend back retainer tabs by striking ball head with heel of your hand.
- Screw in compensation elements by hand as far as they will go, then loosen again by 45°.

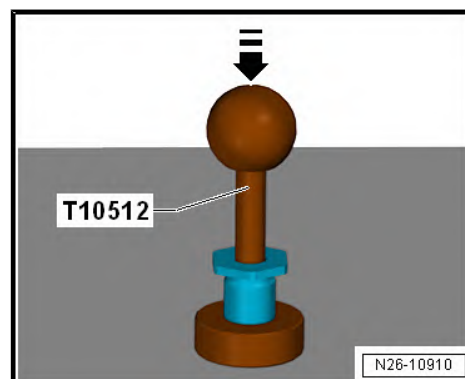
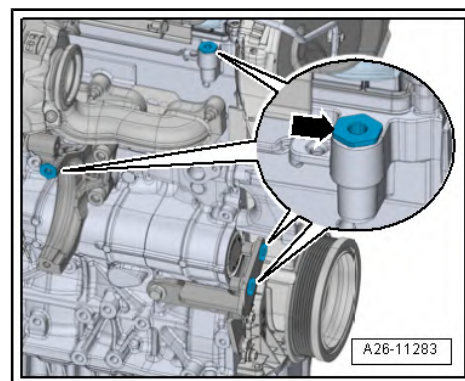

- Fit seal -1- onto emission control module.
- Detach bolt from clip -2- and position clip completely on intake funnel of emission control module. Do not bend open clip.
- Guide emission control module into installation position from below, push upwards and hook retainer into bracket of emission control module.

Emission control module is now suspended approximately in installation position with its weight supported.



**Note**

*Renew all securing bolts of the emission control module after removal.*

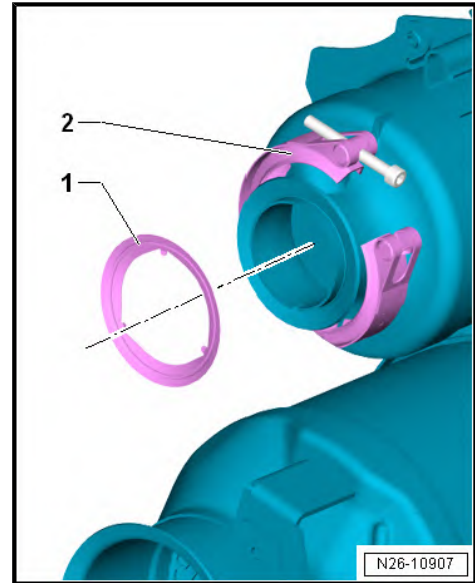

**Tightening sequence for emission control module**

stage	Bolt.	Measure
I	Screw-type clip -1-	Position over sealing flange and engage bolt.
II	Bolt -2-	Tighten by hand and loosen immediately by 90°
III	Screw-type clip -1-	tighten to 8 Nm
IV	Bolt -2-	tighten to 20 Nm
V	Bolt -3-	Insert and press until it engages. Do not tighten or turn bolt.
VI	Bolts -4-	Insert and press until it engages. Tighten bolts to 20 Nm.
VII	Bolt -3-	tighten to 20 Nm

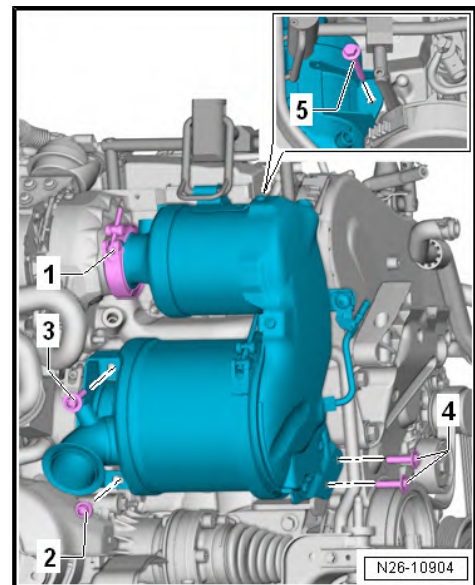

- Unscrew the hydraulic compensation element (left-handed thread) -1- at the cylinder head with an SW 8 socket - 3247- in the -direction of the arrow- until it makes contact, then turn it through a further 90°.

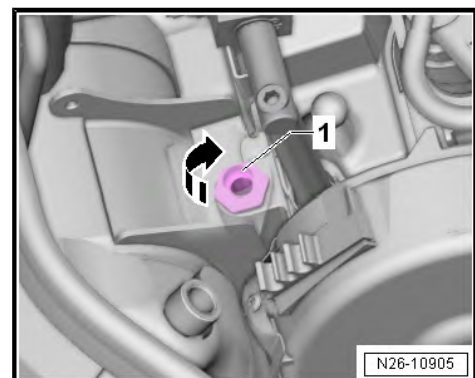

### Tightening sequence continued

stage	Bolt.	Measure
VIII	Bolt -5-	Insert and press until it engages
IX	Bolt -5-	tighten to 20 Nm
X	Bolt -5-	turn 90° further
XI	Bolt -5-	Turn another 45° further.

Further installation is carried out in the reverse order; note the following:

- Install exhaust gas recirculation cooler ⇒ [page 425](#) .
- Install exhaust gas temperature sender ⇒ [page 411](#)
- Install lambda probe 1 before catalytic converter - GX10- .  
⇒ [page 361](#)
- Install lambda probe 1 after catalytic converter - GX7- .  
⇒ [page 361](#)
- Install the coolant pipe (rear) ⇒ [page 217](#) .
- Noise insulation for oil sump.
- Install pendulum support ⇒ [page 49](#) .
- Install the right-hand drive shaft ⇒ Rep. gr. 40 ; Drive shaft; Assembly overview - Drive shaft .
- Install the exhaust pipe ⇒ [page 378](#) .
- Connect coolant hose, and fit hose clip -1-.
- Start bolts -2- and -3-, and tighten them to 10 Nm.

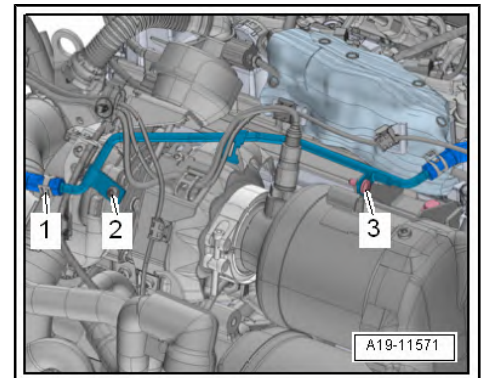
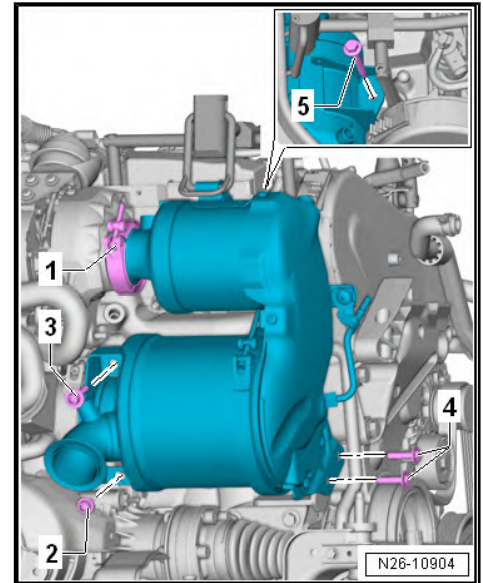

- Connect hoses, and fit hose clips -1-.
- Tighten bolt -3- ⇒ [Item 4 \(page 114\)](#) .
- Screw the differential pressure sensors to the cylinder head ⇒ [Item 6 \(page 93\)](#)
- Electrical connections and routing ⇒ Electrical system; Rep. gr. 97 ; Relay carriers, fuse carriers, electronics boxes; Overview of fitting locations - relay carriers, fuse carriers, electronics boxes and ⇒ Current flow diagrams, Electrical fault finding and Fitting locations.
- Install engine cover panel ⇒ [page 56](#) .
- After renewing emission control module, perform [Adaption](#) in [Guided Functions](#) ⇒ Vehicle diagnostic tester.

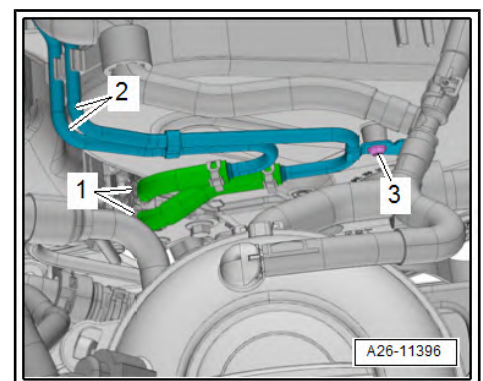

## 2.4.2 Remove and install emission control module, vehicles with four wheel drive



### Note

Amongst others, the emission control module is fixed to the engine with 4 compensation elements. These compensation elements have a left-hand thread on the outside. When the bolt -1- is screwed in, the friction against the retainer tabs -3- initially causes the compensation element -2- to turn as well. Even though the bolt is turned clockwise, the left-hand thread causes the compensation element to move towards the bolt head, which compensates for the play between the components. The compensation element must rotate freely on the left-hand thread, otherwise the retainer tabs will not produce enough friction on the bolt to turn the compensation element. To avoid impairing the required friction, ensure that the retainer tabs do not come in contact with any lubricant.

### Function of compensation element

### Special tools and workshop equipment required

- ◆ Assembly tool - T10511-

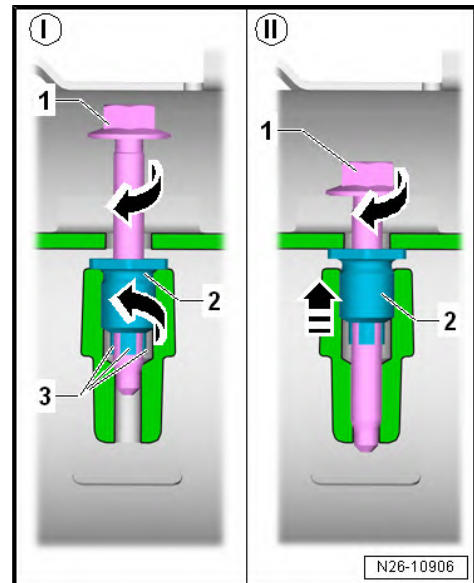

- ◆ Calibration tool - T10512-

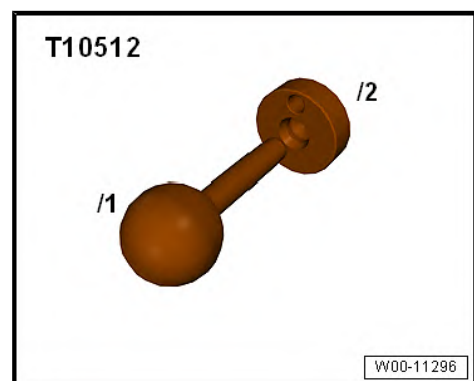

- ◆ Socket 8 mm - 3247-



- ◆ Engine support - T10533-



### Removal

- Remove subframe ⇒ Running gear, axles, steering; Rep. gr. 40 ; Subframe; Removing and installing subframe with steering gear .
- Remove front exhaust pipe ⇒ [page 378](#) .
- If installed, remove screws -arrows- and remove the heat shield -1- .
- Remove the right-hand drive shaft from the flange shaft / from the gearbox ⇒ Rep. gr. 40 ; Drive shaft; Assembly overview – Drive shaft and tie it up to the rear.

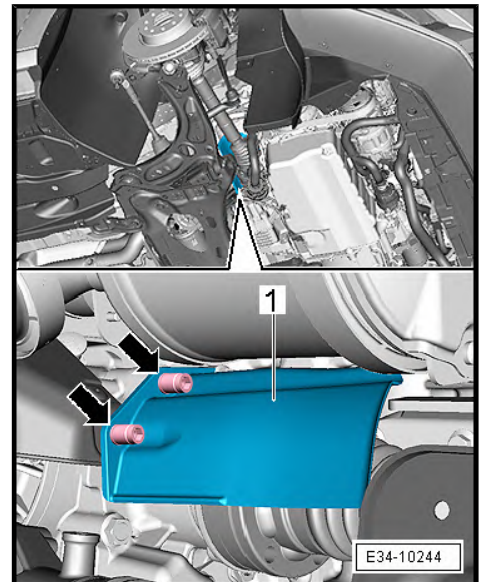

- Remove screws -A- and -B- from the bevel box and remove the heat shield -1- .

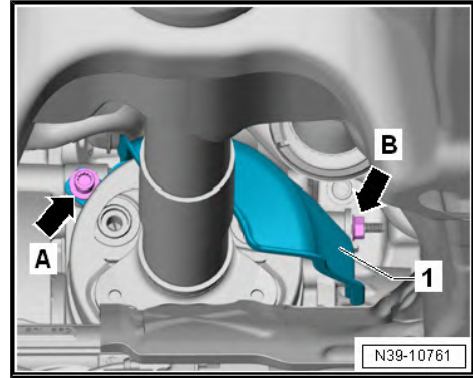

- Also mark the position of the propshaft to the flange of the bevel box.

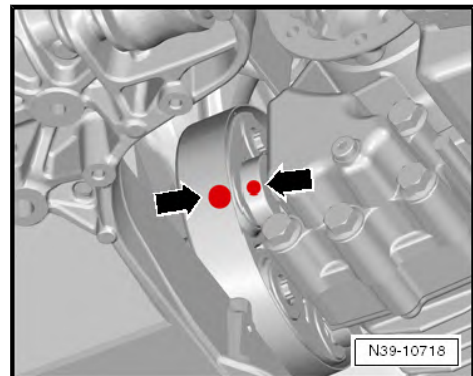

- Unscrew the bolts to secure the propshaft on the front bevel box -arrows-.

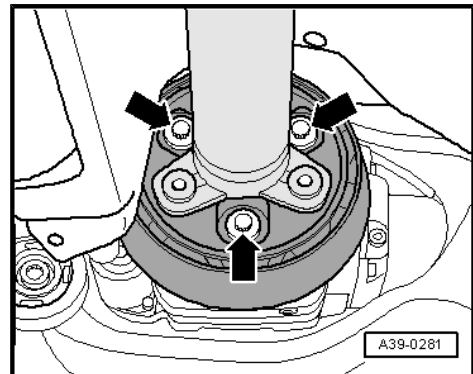

- For removal and installation of screws, counter brackets - T10172- must be used.



**Caution**

*Make sure not to damage the seal -arrow- in the propshaft flange.*

- ◆ *Push the propshaft horizontally to the rear and towards the left side of vehicle as far as possible.*

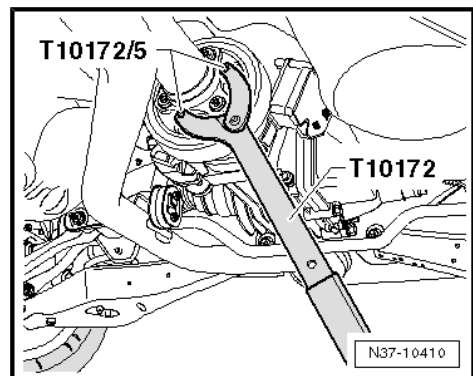

- When removing and placing the propshaft, always make sure that the shaft seal -arrow- is not damaged.
- Push the engine/gear box bracket a bit forward (in the direction of the front end) and separate the propshaft from the flange of the bevel box.

 **Note**

*The propshaft must be renewed if oil seal is damaged.*

- Tie up prop. shaft to left side of vehicle.
- Drain coolant ⇒ [page 181](#) .
- Loosen the hose clip -4-, remove the coolant hose, drain the coolant.
- Loosen the hose clips -1-, remove the coolant hoses.
- Remove nut -3- and bolt -2- and detach coolant pipe (rear).

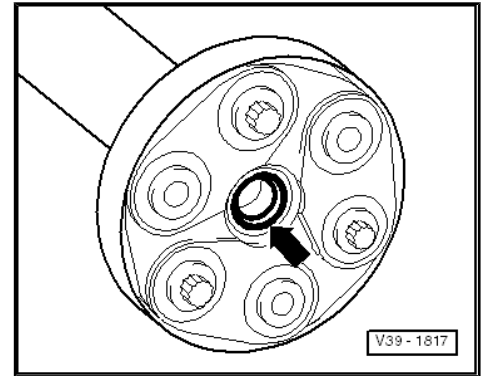

 **Note**

*Use the hook to disconnect the -plug - connection 5 - T40207- .  
Release the plug lock -1- -in the direction of the arrow-.*

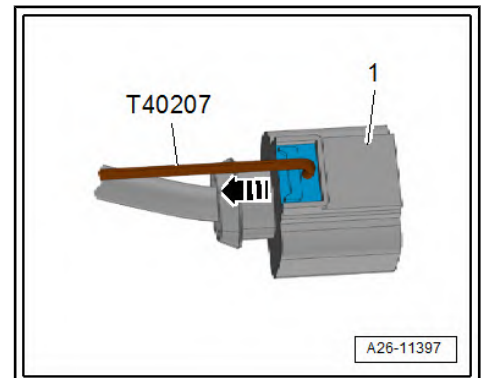
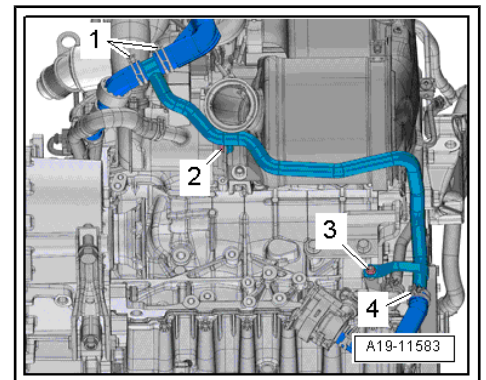

- Push heat insulation sleeve to one side and unplug electrical connector -5-.
- Remove hose clamps -4- and -7- and pull the hoses from the radiator for exhaust gas return.
- Loosen bolt -6- and push screw-type clip towards particulate filter.
- Remove hose clamp -3- of the air hose.
- Remove bolt -2- using the XZN 10 - T10501- .

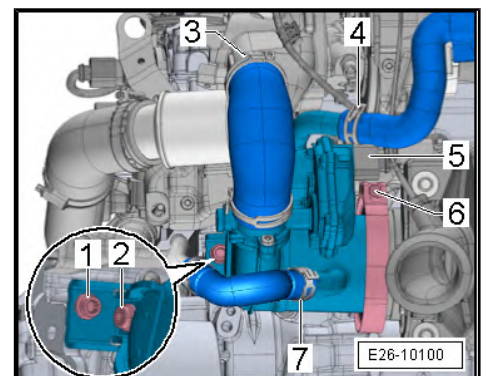

- Using a screwdriver, release fasteners -arrow- and move coolant expansion tank to one side.
- Remove exhaust temperature sender 3 - G495-  
⇒ [page 411](#) .
- Remove exhaust temperature sender 2 - G448-  
⇒ [page 411](#) .
- Remove exhaust temperature sender 4 - G648-  
⇒ [page 411](#) .
- Remove lambda probe 1 before catalytic converter - GX10-  
⇒ [page 362](#) .
- If fitted, remove lambda probe 1 after catalytic converter - GX7- ⇒ [page 363](#) .

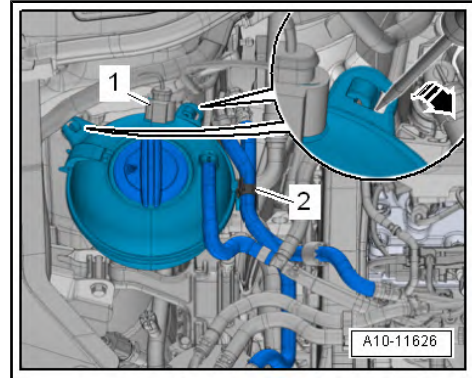

#### Vehicles with pressure differential sender - G505-

- Open heat insulation sleeve -1-.
- Take electrical connector -4- out of bracket, unplug it and move electrical wiring clear.
- Disconnect the electrical connector -3-, -5- and expose the wiring harness.
- Remove bolt -2- and move bracket with pressure differential sender - G505- towards rear.

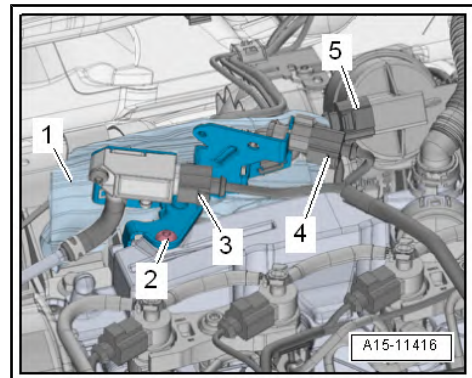

- Remove bolt -arrows-.
- Release clip -A-, disconnect hose, unclip pipe -B- and detach together with pressure differential sender - G505- .

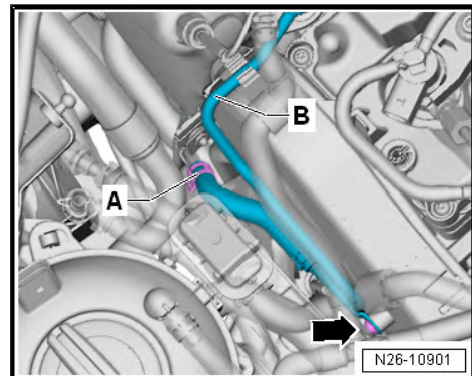

#### Vehicles with pressure differential sender - G505- and pressure sensor 1 for exhaust - G450-

- Open heat insulation sleeve -1-.
- Take electrical connector -5- out of bracket, unplug it and move electrical wiring clear.
- Disconnect electrical connectors -3, 4 and 6- and move wiring harness clear.
- Unscrew the bolt -2-.

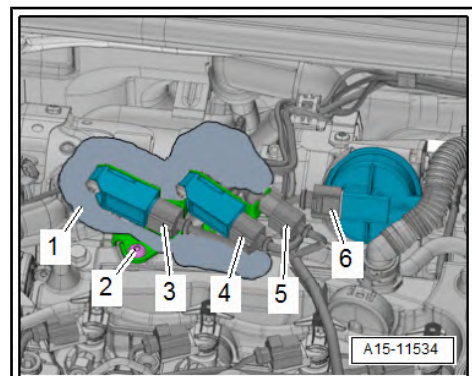

- Unscrew the bolt -3-.
- Undo the hose clips -1- and remove the hoses.
- Unhook pipe line -2- and remove with the pressure differential senders.

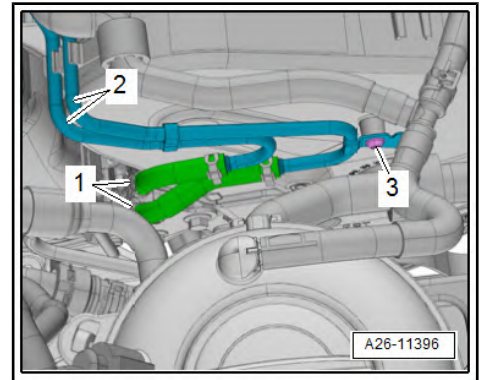

**All vehicles (continued):**

- Open clamp -1- and pull coolant hose.
- Remove bolts -2- and -3- and pivot coolant pipe clear to one side.

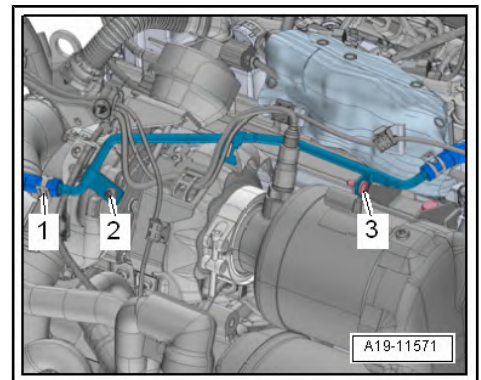

- Remove bolt -arrows-.

 **Note**

*The feet of the assembly tool - T10511- rest on the bolt heads in the cylinder head cover.*

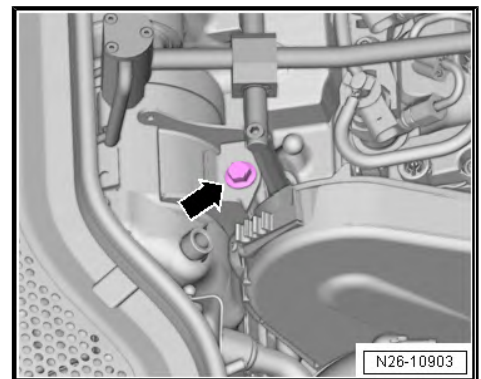

- Set up assembly aid - T10511- as shown and engage retainer -arrow- in bracket of emission control module.

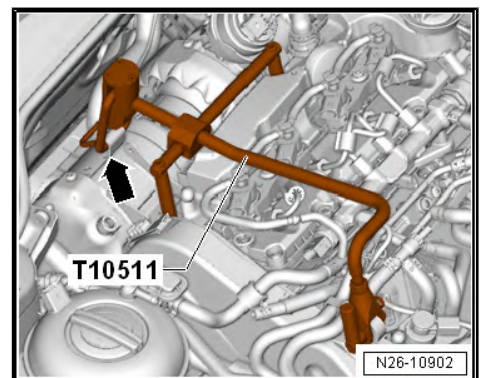

- Remove screws -4-.
- Remove bolts -5, 6- using the XZN 10 - T10501- .
- Pull down the mechanism -2- of the assembly tool - T10511- in -the direction of the arrow- in order to release the bracket from the tab on the emission control module

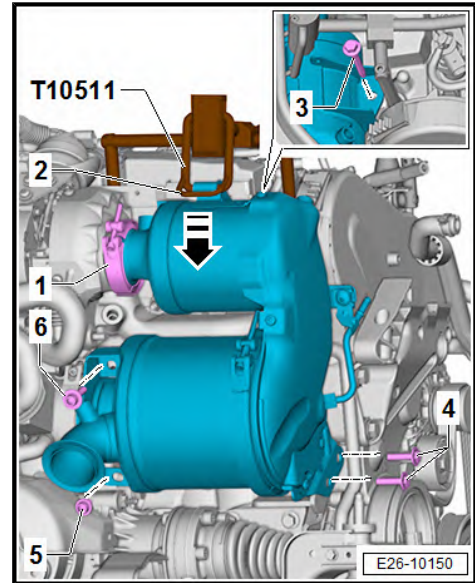

- Separate the exhaust gas recirculation cooler -1- from the emission control module -2- -arrows-.

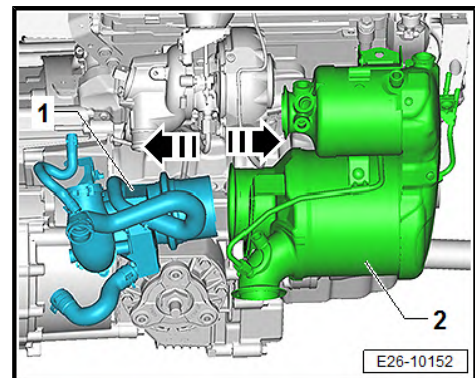

- Move the exhaust treatment module -1- down.

### Installation

- Assembly aid - T10511- set up on engine

### Note

- ◆ *Ensure that the retaining bar of the assembly tool - T10511- is »opened« towards plenum chamber bulkhead.*
- ◆ *Renew gaskets, self-locking nuts and screw-type clamp for emission control module after removal.*
- ◆ *Fit all cable ties and heat insulation sleeves in the original positions when installing.*

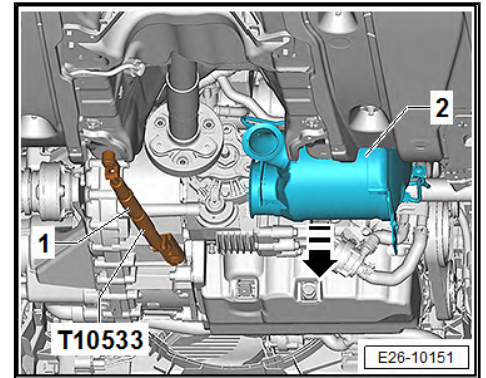

### Caution

***Emission control module must be installed free of tension to avoid risk of stress fractures and engine damage.***

- ◆ *Prior to installation, ensure that the compensation elements move easily and do not stick.*
- ◆ *Compensation element must turn easily on its threads.*
- ◆ *Only apply lubricant to thread; retainer tabs must remain »clean«.*
- ◆ *The retainer tabs for the bolt must be bent together so that when the bolt is screwed in, the compensation element turns as well.*

- Check that compensation elements -arrow- are free to move.
- Unscrew compensation elements completely in clockwise direction (left-hand thread).
- Clean any threads that do not turn easily and lubricate lightly with rust remover if necessary.

### Caution

***Ensure that no lubricant gets on the retainer tabs of the compensation elements. If the friction is reduced, functional impairment of the compensation elements will be the result.***

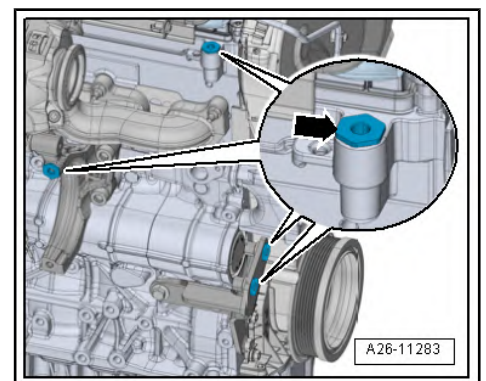

- Adjust retainer tabs to functional dimension using calibration tool - T10512- as follows:
- Slide compensation element onto pin, insert into centring sleeve and bend back retainer tabs by striking ball head with heel of your hand.
- Screw in compensation elements by hand as far as they will go, then loosen again by 45°.

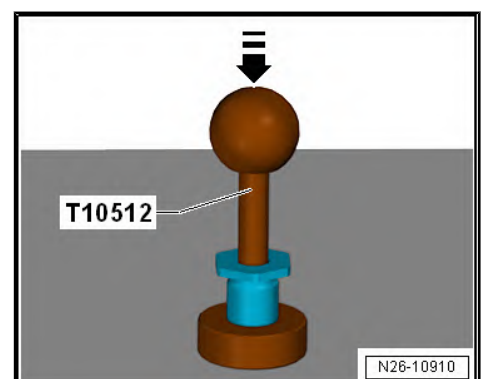

- Fit seal -1- onto emission control module.
- Detach bolt from clip -2- and position clip completely on intake funnel of emission control module. Do not bend open clip.

#### Vehicles with RHD

- With the aid of a second mechanic, push engine downward towards front.

#### All vehicles (continued):

- Guide emission control module into installation position from below, push upwards and hook retainer into bracket of emission control module.

Emission control module is now suspended approximately in installation position with its weight supported.



#### Note

Renew all securing bolts of the emission control module after removal.

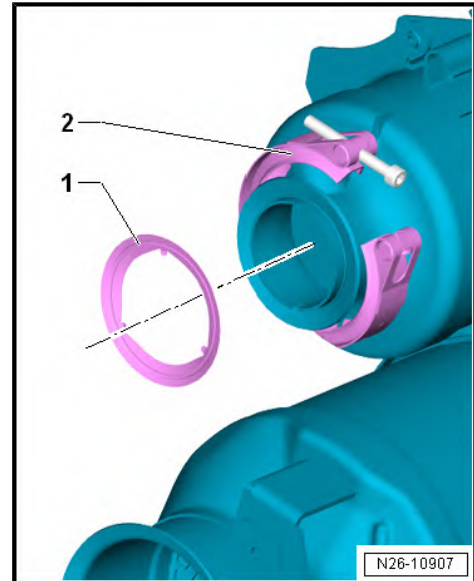

#### Tightening sequence for emission control module

stage	Bolt.	Measure
I	Screw-type clip -1-	Position over sealing flange and engage bolt.
II	Bolt -2-	Tighten by hand and loosen immediately by 90°
III	Screw-type clip -1-	tighten to 8 Nm
IV	Bolt -2-	tighten to 20 Nm
V	Bolt -3-	Insert and press until it engages. Do not tighten or turn bolt.
VI	Bolts -4-	Insert and press until it engages. Tighten bolts to 20 Nm.
VII	Bolt -3-	tighten to 20 Nm

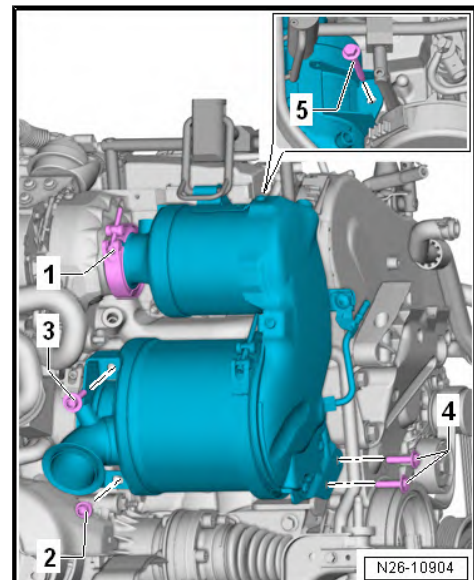

- Unscrew the hydraulic compensation element (left-handed thread) -1- at the cylinder head with an SW 8 socket - 3247- in the -direction of the arrow- until it makes contact, then turn it through a further 90°.

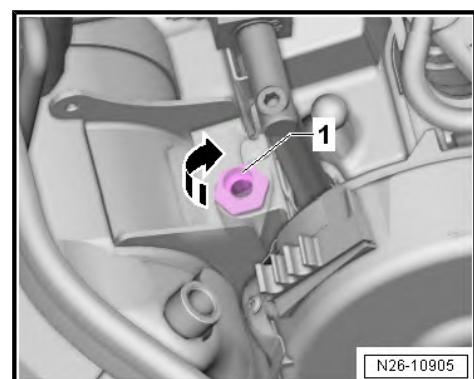

### Tightening sequence continued

stage	Bolt.	Measure
VIII	Bolt -5-	Insert and press until it engages
IX	Bolt -5-	tighten to 20 Nm
X	Bolt -5-	turn 90° further
XI	Bolt -5-	Turn another 45° further.

Further installation is carried out in the reverse order; note the following:

- Install exhaust gas recirculation cooler ⇒ [page 431](#) .
- Install the coolant pipe (rear) ⇒ [page 217](#) .
- Install front exhaust pipe ⇒ [page 378](#) .
- Bolt prop. shaft to bevel box ⇒ Rep. gr. 39 ; Prop. shaft; Removing and installing prop. shaft .
- Screw down the right-hand drive shaft ⇒ Rep. gr. 40 ; Drive shaft; Assembly overview: Drive shaft .
- Connect coolant hose, and fit hose clip -1-.
- Start bolts -2- and -3-, and tighten them to 10 Nm.

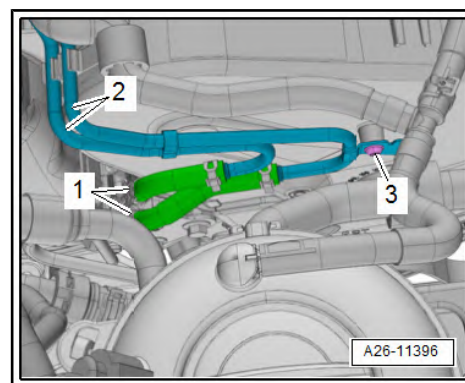
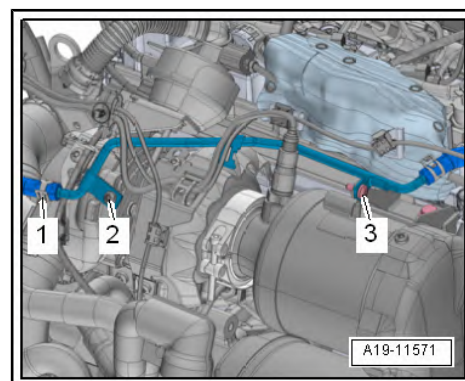
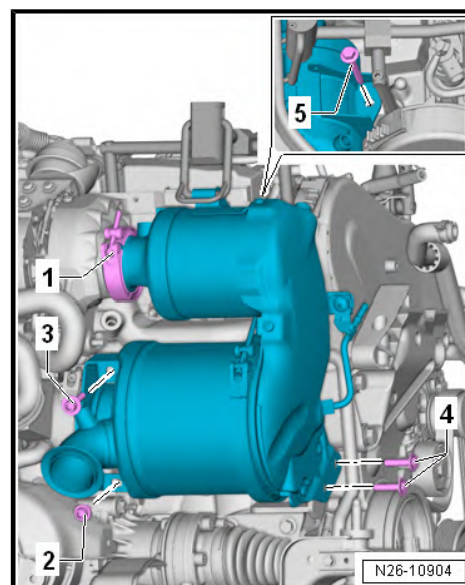

- Connect hoses, and fit hose clips -1-.
- Tighten bolt -3- ⇒ [Item 4 \(page 114\)](#) .
- Screw the differential pressure sensors to the cylinder head ⇒ [Item 6 \(page 93\)](#)
- Electrical connections and routing ⇒ Electrical system; Rep. gr. 97 ; Relay carriers, fuse carriers, electronics boxes; Overview of fitting locations - relay carriers, fuse carriers, electronics boxes and ⇒ Current flow diagrams, Electrical fault finding and Fitting locations.
- Install subframe ⇒ Running gear, axles, steering; Rep. gr. 40 ; Subframe; Removing and installing subframe with steering box .
- Install engine cover panel ⇒ [page 56](#) .
- After renewing emission control module, perform [Adaption](#) in [Guided Functions](#) ⇒ Vehicle diagnostic tester.

## 2.5 Removing and installing exhaust flap control unit - J883-

### Removal

Remove the lower centre noise insulation ⇒ General body repairs, exterior; Rep. gr. 66 ; undercarriage panel

- If fitted, remove heat insulation sleeve from connector.
- Unplug the electrical connector -1-.
- Unscrew bolts -arrows- and remove exhaust flap control unit - J883- .

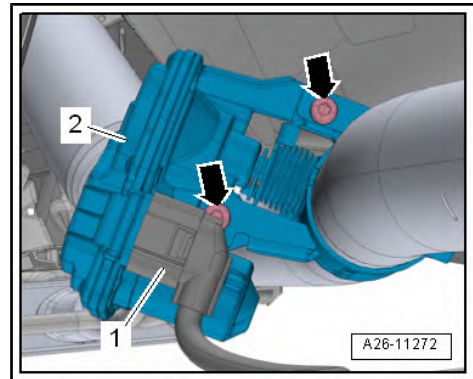

### Installation

- Fit new exhaust flap control unit - J883- . Make sure that the follower of the control unit -1- engages properly in the tab of the exhaust flap -2-.
- Insert new securing bolts, and start new nuts.

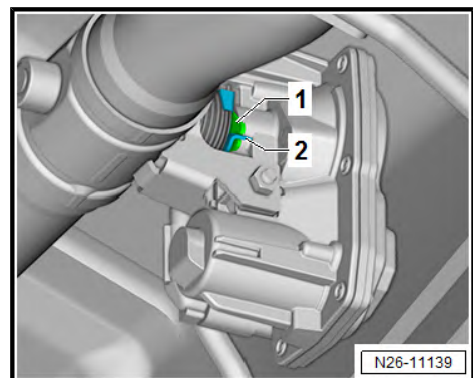

- First tighten upper bolt, then tighten lower bolt ⇒ [page 366](#) .
- Remove protective cap of electrical connector and insert plug connector -1-. If applicable, fasten the head protection sleeve.
- After renewing the exhaust flap control unit - J883- , adapt learnt values in engine control unit. To do this, switch on ignition and select the following menu item in the vehicle diagnostic and service information system :

◆ `Adapt exhaust flap`

### Specified torques

- ◆ ⇒ ["1.1 Exploded view - silencers", page 366](#)
- ◆ Install the lower centre noise insulation ⇒ General body repairs, exterior; Rep. gr. 66 ; undercarriage panel

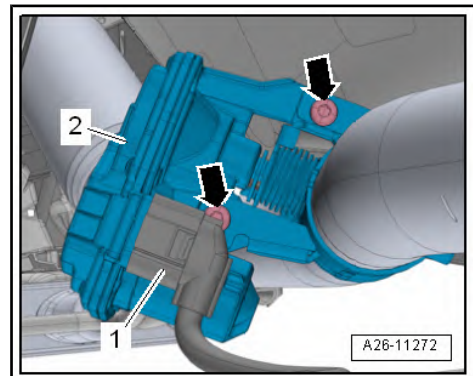

### 3 Exhaust gas temperature control

⇒ [“3.1 Assembly overview - exhaust gas temperature regulation”, page 411](#)

⇒ [“3.2 Removing and installing exhaust gas temperature sensor 1 G235”, page 413](#)

⇒ [“3.3 Removing and installing exhaust gas temperature sender 2 G448”, page 414](#)

⇒ [“3.4 Removing and installing exhaust gas temperature sensor 3 G495”, page 416](#)

⇒ [“3.5 Removing and installing exhaust gas temperature sender 4 G648”, page 417](#)

#### 3.1 Assembly overview - exhaust gas temperature regulation



##### Caution

*Risk of malfunctions caused by improperly secured exhaust gas temperature sensors.*

- ◆ *The threads of the exhaust gas temperature sensors - G495- and -G648- are coated. Do NOT additionally grease with high-temperature paste and always adhere to the specified tightening torque .*

**1 - Lambda probe 1 after catalytic converter - GX7-**

Consisting of: Lambda probe after catalytic converter - G130- and Heater for lambda probe 1, after catalytic converter - Z29-

- If fitted
- Removing and fitting ⇒ [page 363](#)
- Follow installation instructions

**2 - Exhaust gas temperature sender 4 - G648-**

- If fitted
- Removing and installing ⇒ [page 417](#)
- 2.0 l engines: 60 Nm
- 1.6 l engines: 45 Nm

**3 - Exhaust gas temperature sender 1 - G235-**

- Removing and fitting ⇒ [page 413](#)
- Coat with high-temperature paste; high-temperature paste ⇒ Electronic parts catalogue .
- 45 Nm

**4 - Exhaust gas temperature sender 2 - G448-**

- If fitted
- Removing and fitting ⇒ [page 414](#)
- 60 Nm

**5 - Bolt.**

- Tightening torque ⇒ [page 361](#)

**6 - Pressure differential sender - G505-**

- Removing and fitting ⇒ [page 341](#)

**7 - Bracket/bearing/support**

- To pressure differential sender - G505-

**8 - Pressure sensor 1 of exhaust gases - G450-**

- If fitted
- Removing and fitting ⇒ [page 345](#)

**9 - Bolt.**

- Tightening torque ⇒ [Item 9 \(page 361\)](#)

**10 - Exhaust gas temperature sender 3 - G495-**

- If fitted
- Removing and installing ⇒ [page 416](#)
- 2.0 l engines: 60 Nm
- 1.6 l engines: 45 Nm

**11 - Lambda sensor 1 before catalytic converter - GX10-**

Comprising: lambda probe - G39- with lambda probe heating - Z19- .

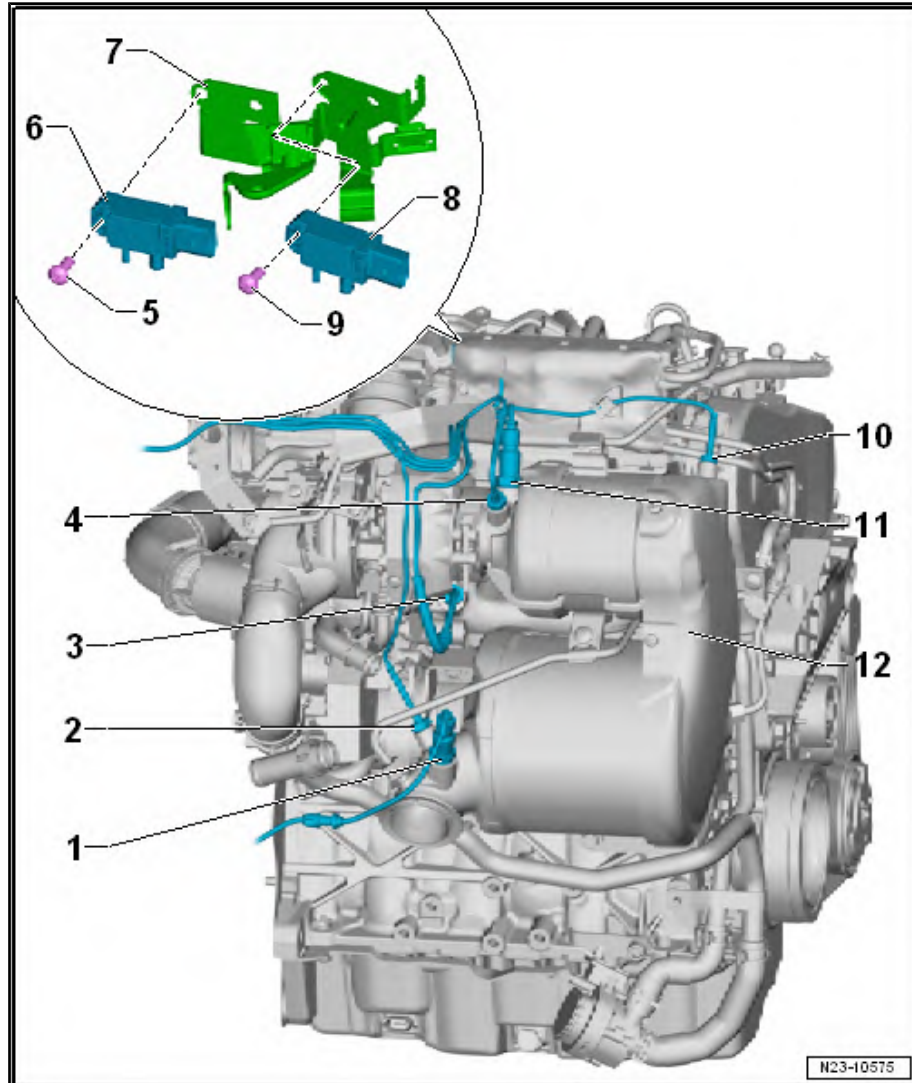

- Removing and fitting ⇒ [page 362](#)

## 12 - Emission control module

### 3.2 Removing and installing exhaust gas temperature sensor 1 - G235-

#### Special tools and workshop equipment required

- ◆ Wrench kit - T10395 A-



- ◆ Additional tool set - T10395/5-
- ◆ Torque wrench - V.A.G 1331-



#### Removing



#### Note

- ◆ *Attach cable ties in all the same places when installing.*
  - ◆ *When removing, the electrical wiring must not be cut, otherwise a fault diagnosis would no longer be possible.*
- Remove engine cover. ⇒ [page 56](#)
- Vehicles with engine codes CRVA, CRVC:**
- Release and unplug electrical connector -1-.

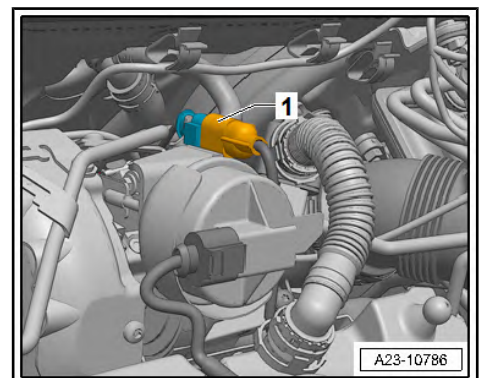

**Vehicles with all other engine codes:**

- Open heat insulation sleeve -2-.
- Release and unplug electrical connector -1-.

**Continued procedure for all vehicles**

- Move clear electrical wiring harness -arrows-.
- Screw out the exhaust gas temperature senders 1 - G235-3- with the wrench set - T10395/5- .

**Installation**

Installation is carried out in the reverse order; note the following:

- Tightening torque  
⇒ ["3.1 Assembly overview - exhaust gas temperature regulation", page 411](#)

**Note**

- ◆ *Take care to protect exhaust gas temperature sender from knocks and impact; if dropped, the exhaust gas temperature sender can no longer be used.*
- ◆ *Coat thread with high-temperature paste; high-temperature paste ⇒ [Electronic parts catalogue](#)*

Installation position of exhaust gas temperature sensor -G235- .

- Angled part of shaft -1- positioned vertically downward.
- Electrical connections and routing ⇒ Electrical system; Rep. gr. 97 ; Relay carriers, fuse carriers, electronics boxes; Overview of fitting locations - relay carriers, fuse carriers, electronics boxes and ⇒ Current flow diagrams, Electrical fault finding and Fitting locations.and ⇒ Current flow diagrams, Electrical fault finding and Fitting locations
- Install engine cover panel ⇒ [page 56](#) .

**Specified torques**

- ◆ ⇒ ["3.1 Assembly overview - exhaust gas temperature regulation", page 411](#)

**3.3 Removing and installing exhaust gas temperature sender 2 - G448-**

**Special tools and workshop equipment required**

- ◆ Tool set - T10395 A-

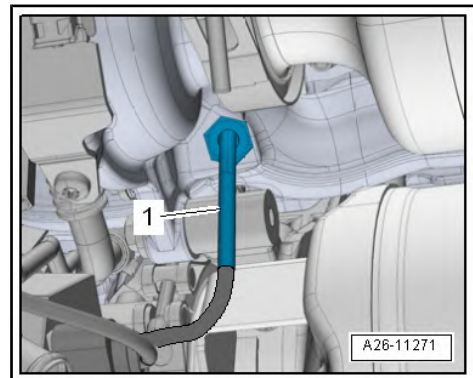
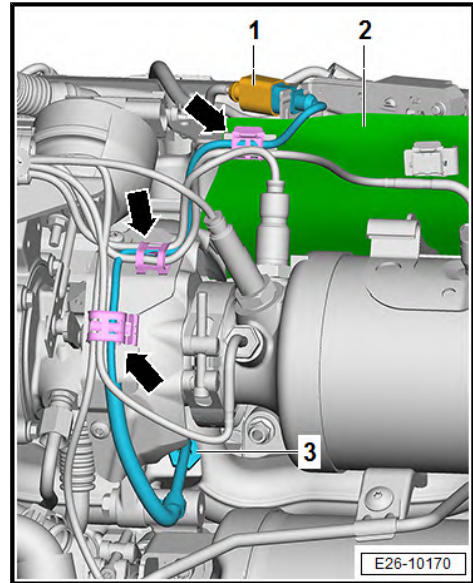

- ◆ Additional tool set - T10395/8-

- ◆ Lambda probe open ring spanner - 3337/7-

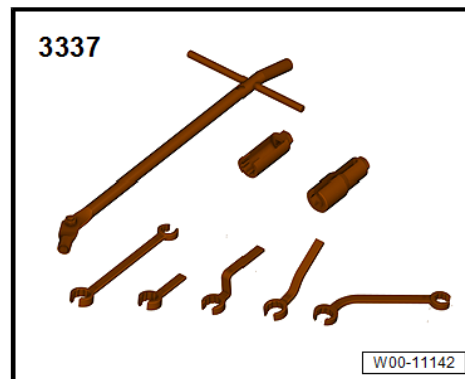

- ◆ Torque wrench - V.A.G 5820-

### Removing



#### Note

- ◆ *When fitting, attach all cable ties back to the same location.*
- ◆ *When removing, the electrical wiring must not be cut, otherwise a fault diagnosis would no longer be possible.*
- Remove engine cover. ⇒ [page 56](#)
- Release and pull off the connector on plenum chamber bulkhead -arrow- ⇒ [page 293](#) .
- For space reasons, disconnect the Lambda probe 1 before catalytic converter - GX10- -4- from the emission control module -2- ⇒ [page 362](#) .
- Unscrew the exhaust gas temperature sender 2 - G448- -3- with a tool from the set of wrenches - T10395/8- .

### Installation

Installation is carried out in the reverse order; note the following:



#### Caution

***Risk of malfunctions caused by improperly secured exhaust gas temperature sensors.***

- ◆ ***Thread of exhaust gas temperature sender 2 - G448- is coated. Do NOT additional grease with high-temperature paste and make sure to tighten to the specified tightening torque.***

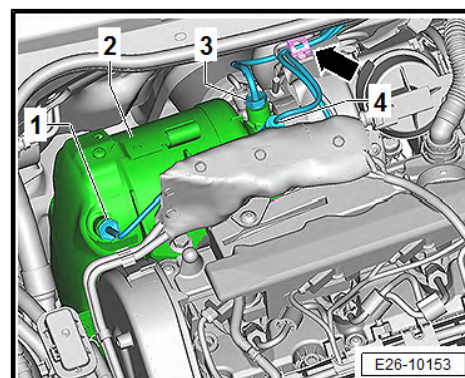

- Attach cable ties in all the same places when installing.



#### Note

*Take care to protect exhaust gas temperature sender from knocks and impact; if dropped, the exhaust gas temperature sender can no longer be used.*

Installation position of the exhaust gas temperature sender 2 - G448- :

- The angled shaft -1- must be positioned vertically upwards.
- Electrical connections and routing ⇒ Electrical system; Rep. gr. 97 ; Relay carriers, fuse carriers, electronics boxes; Overview of fitting locations - relay carriers, fuse carriers, electronics boxes and ⇒ Current flow diagrams, Electrical fault finding and Fitting locations.
- Install engine cover panel ⇒ [page 56](#) .

#### Specified torques

- ◆ Assembly overview - exhaust gas temperature regulation ⇒ [“3.1 Assembly overview - exhaust gas temperature regulation”, page 411](#)

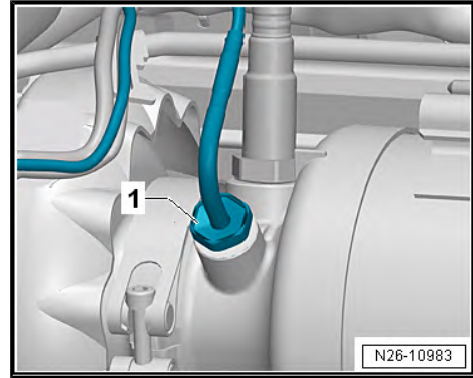

### 3.4 Removing and installing exhaust gas temperature sensor 3 - G495-

Special tools and workshop equipment required

- ◆ Wrench kit - T10395 A-



- ◆ Suitable socket SW 17 for engine 1.6 l tool set supplement - T10395/5-
- ◆ Suitable socket SW 19 for engine 2.0 l tool set supplement - T10395/9-

#### Removing



#### Note

- ◆ *When fitting, attach all cable ties back to the same location.*
- ◆ *When removing, the electrical wiring must not be cut, otherwise a fault diagnosis would no longer be possible.*
- Remove engine cover. ⇒ [page 56](#)

- Release and pull off the connector on plenum chamber bulk-head -arrow- => [page 293](#) .
- Unscrew exhaust temperature sender 3 - G495- -1-.

### Installation

Installation is carried out in the reverse order; note the following:

- Attach cable ties in all the same places when installing.



### Caution

*Risk of malfunctions caused by improperly secured exhaust gas temperature sensors.*

- ◆ *The threads of the exhaust gas temperature sensors - G495- and -G648- are coated. Do NOT additionally grease with high-temperature paste and always adhere to the specified tightening torque .*

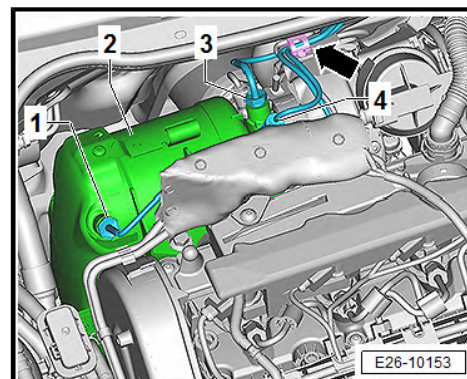

### Note

*Take care to protect exhaust gas temperature sender from knocks and impact; if dropped, the exhaust gas temperature sender can no longer be used.*

- Electrical connections and routing => Electrical system; Rep. gr. 97 ; Relay carriers, fuse carriers, electronics boxes; Overview of fitting locations - relay carriers, fuse carriers, electronics boxes and => Current flow diagrams, Electrical fault finding and Fitting locations.
- Install engine cover panel => [page 56](#) .

### Specified torques

- ◆ Assembly overview - exhaust gas temperature regulation => ["3.1 Assembly overview - exhaust gas temperature regulation"](#), [page 411](#)

## 3.5 Removing and installing exhaust gas temperature sender 4 - G648-

Special tools and workshop equipment required

- ◆ Tool set - T10395 A-



- ◆ Additional tool set - T10395/8-/10-

- ◆ Torque wrench - V.A.G 1331-

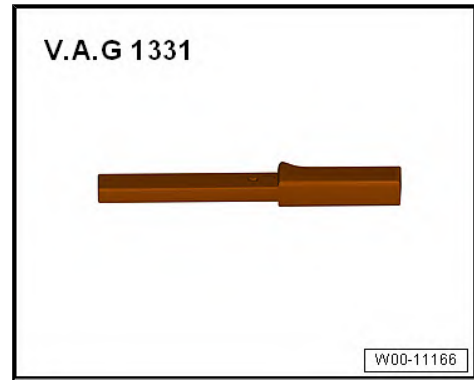

- ◆ Torque wrench - V.A.G 1332-



## Removal



### Note

- ◆ *Attach cable ties in all the same places when installing.*
- ◆ *When removing, the electrical wiring must not be cut, otherwise a fault diagnosis would no longer be possible.*
- Remove engine cover. ⇒ [page 56](#)
- Release and pull off connector on plenum chamber bulkhead ⇒ [page 293](#) .

- Unscrew exhaust temperature sender 4 - G648- -1-.

#### Installation

Installation is carried out in the reverse order; note the following:

- Attach cable ties in all the same places when installing.



#### Caution

*Risk of malfunctions caused by improperly secured exhaust gas temperature sensors.*

- ◆ *The threads of the exhaust gas temperature sensors - G495- and -G648- are coated. Do NOT additionally grease with high-temperature paste and always adhere to the specified tightening torque .*

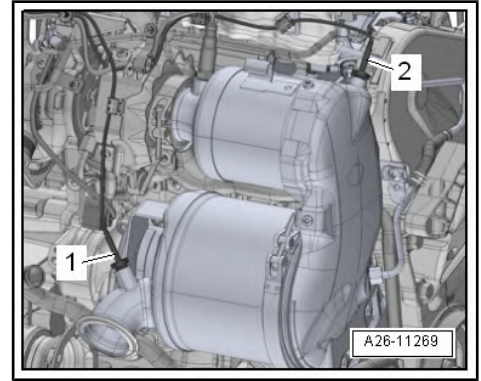

#### Note

*Take care to protect exhaust gas temperature sender from knocks and impact; if dropped, the exhaust gas temperature sender can no longer be used.*

- Observe electrical connections and routing ⇒ Electrical system; Rep. gr. 97 ; Relay carriers, fuse carriers, electronics boxes; Overview of fitting locations - relay carriers, fuse carriers, electronics boxes and ⇒ Current flow diagrams, Electrical fault finding and Fitting locations.
- Install engine cover panel ⇒ [page 56](#) .

#### Specified torques

- ◆ Assembly overview - exhaust gas temperature regulation ⇒ ["3.1 Assembly overview - exhaust gas temperature regulation", page 411](#)

## 4 Exhaust gas recirculation

⇒ [“4.1 Assembly overview - exhaust gas recirculation”, page 420](#)

⇒ [“4.2 Assembly overview - Control motor for exhaust gas recirculation V338”, page 425](#)

⇒ [“4.3 Removing and installing exhaust gas recirculation cooler”, page 425](#)

⇒ [“4.4 Removing and installing exhaust gas recirculation control motor V338”, page 439](#)

⇒ [“4.5 Removing and installing exhaust gas recirculation control motor 2 V339”, page 440](#)

⇒ [“4.6 Check seal integrity of exhaust recirculation cooler”, page 441](#)

### 4.1 Assembly overview - exhaust gas recirculation

⇒ [“4.1.1 Assembly overview - exhaust gas recirculation”, page 420](#)

⇒ [“4.1.2 Assembly overview – exhaust gas recirculation, engine codes CRVA, CRVC, CRGA”, page 422](#)

#### 4.1.1 Assembly overview - exhaust gas recirculation

Observe rules for cleanliness ⇒ [page 13](#) .

**1 - Exhaust gas recirculation cooler**

- Removing and fitting  
⇒ [page 425](#)

**2 - Bolt.**

- Tightening torque and sequence ⇒ [page 422](#) if only exhaust gas recirculation cooler was removed

**3 - Bracket/bearing/support**

- for the exhaust gas recirculation cooler

**4 - Bolt.**

- Tightening torque and sequence ⇒ [page 422](#) if only exhaust gas recirculation cooler was removed

**5 - Screw-type clip**

- Renew following removal
- Installation position  
⇒ [page 422](#)
- Tightening torque and sequence ⇒ [page 422](#)

**6 - Seal**

- Renew following removal

**7 - Emission control module**

- Removing and fitting  
⇒ [page 390](#)

**8 - Control motor 2 for exhaust gas recirculation - V339-**

- Removing and fitting ⇒ [page 440](#)

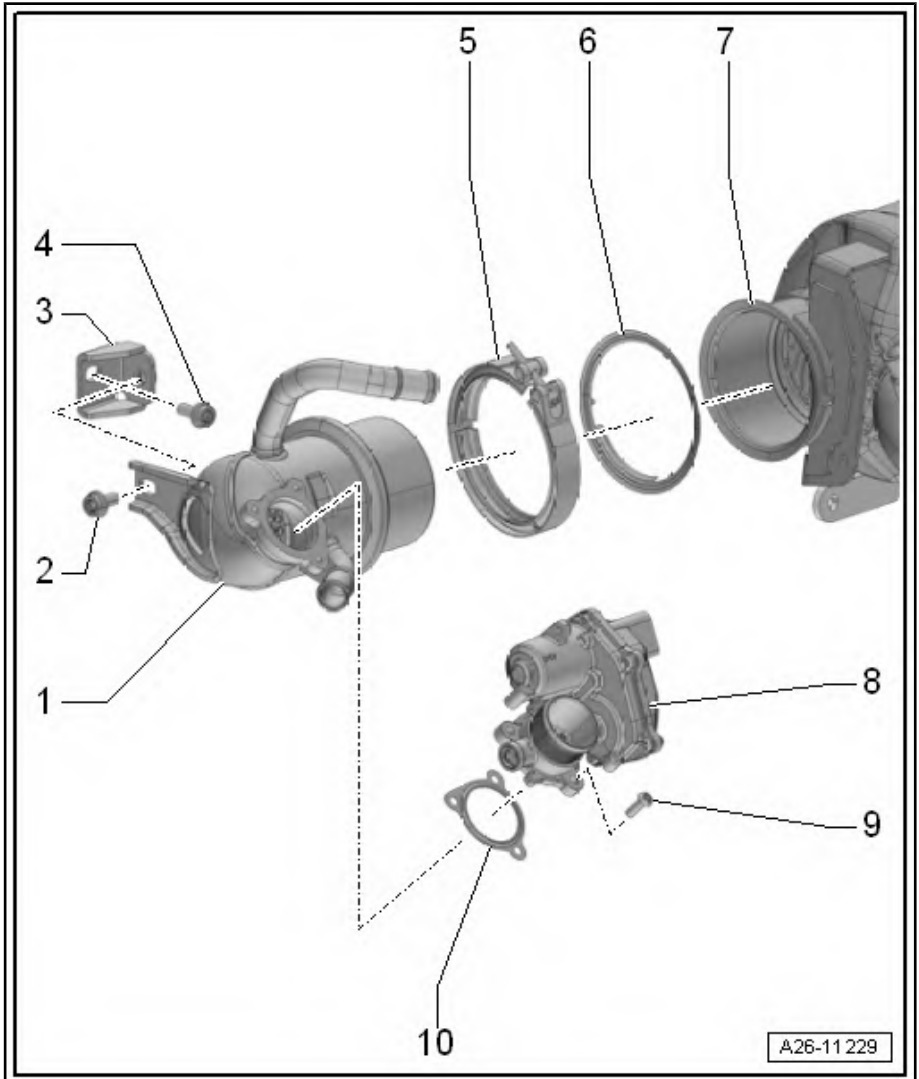

**Caution**

*The exhaust gas recirculation control motor is protected against damage caused by heat with an insulation mat. If the insulation mat is damaged, renew it and check the control motor for damage caused by heat. Renew control motor as well, if necessary.*

**9 - Bolt.**

- 9 Nm

**10 - Seal**

- Renew following removal

### Installation position of air hose on exhaust gas recirculation cooler

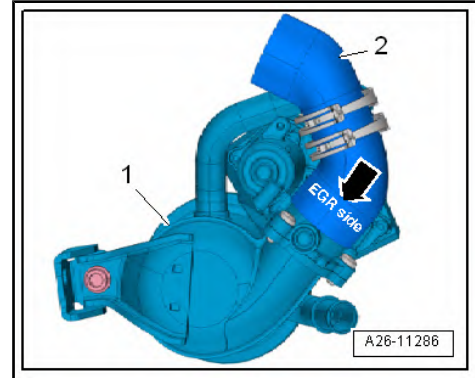

### Installation position of screw-type clip for exhaust gas recirculation cooler

- Angle  $\alpha$  = 10 ... 15°

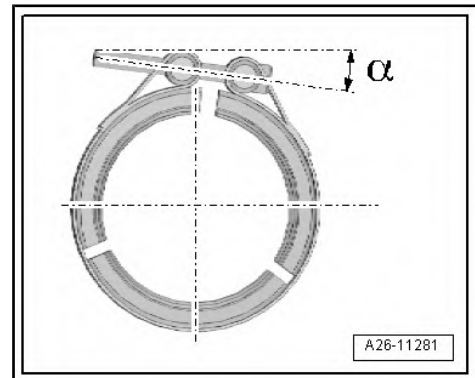

### Exhaust gas recirculation cooler - tightening torque and sequence

– Tighten bolts in stages in the sequence shown:

stage	Bolts	Tightening torque
1st	Screw-type clip -3-	7 Nm
2nd	-1, 2-	Screw in by hand until they make contact
3.	-1, 2-	20 Nm

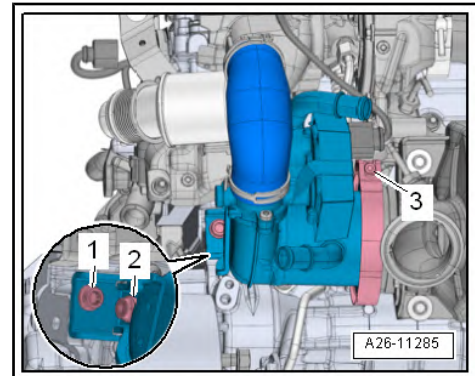

## 4.1.2 Assembly overview – exhaust gas recirculation, engine codes CRVA, CRVC, CRGA

**1 - Seal**

- Renew following removal

**2 - Connection pipe**

- To the exhaust inlet manifold

**3 - Nut**

- Renew following removal
- 20 Nm

**4 - Bolt.**

- Renew following removal
- 8 Nm

**5 - Bolt.**

- Renew following removal
- 20 Nm

**6 - Exhaust gas recirculation temperature sensor - G98-**

- Remove using a tool from the wrench set - T10395 A- .

**7 - Two-threaded bolt**

- Renew following removal
- 20 Nm

**8 - Vacuum line**

**9 - Bolt.**

- 8 Nm

**10 - Vacuum line**

**11 - Exhaust gas recirculation radiator change-over valve - N345-**

- Location ⇒ [page 424](#)

**12 - Connection pipe**

- To cylinder head

**13 - Bolt.**

- Renew following removal
- 20 Nm

**14 - Bolt.**

- Observe tightening sequence ⇒ [page 424](#) .

**15 - Bracket/bearing/support**

- for the exhaust gas recirculation cooler
- Bolted to engine block
- Observe tightening sequence ⇒ [page 424](#) .

**16 - Bolt.**

- 20 Nm

**17 - Exhaust gas recirculation cooler**

- Removing and fitting ⇒ [page 436](#)

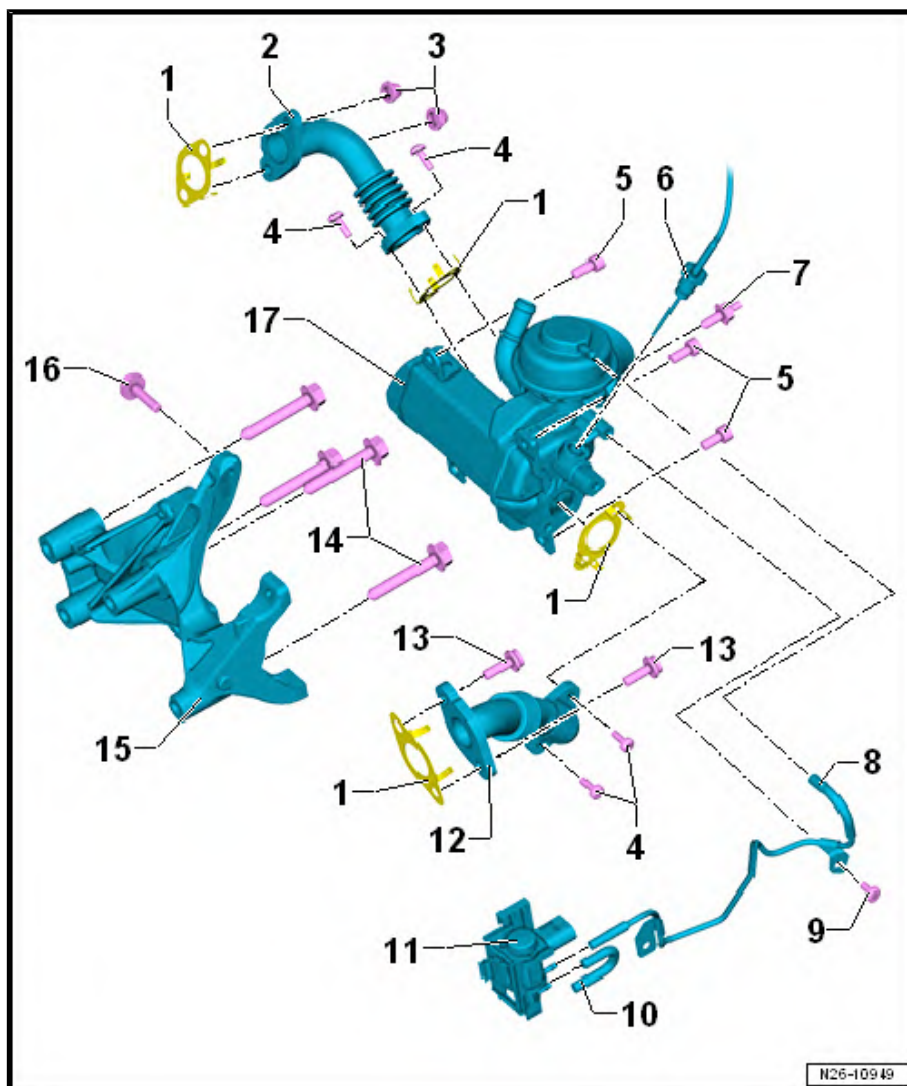

☐ Check for leaks ⇒ [page 441](#)

**Tightening torques and sequence for mounting of exhaust gas recirculation cooler**

stage	Bolts	Tightening torque
1st	-2 ... 5-	Screw in by hand until they make contact
2nd	-1-	Tighten to 20 Nm
3.	-2 ... 5-	Tighten to 55 Nm

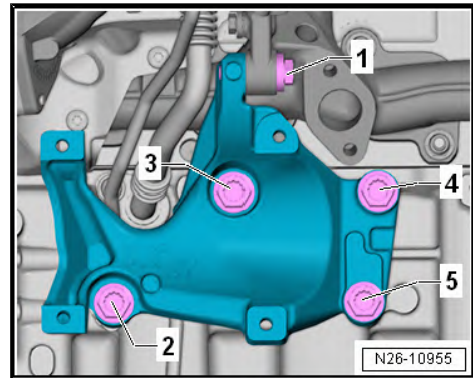

**Exhaust gas recirculation cooler change-over valve - N345- -1-**

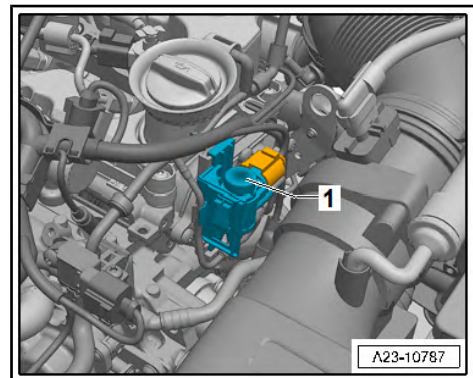

## 4.2 Assembly overview - Control motor for exhaust gas recirculation - V338-

1 - Coolant hoses

2 - Spring type clip

3 - Exhaust gas recirculation control motor - V338-

With exhaust gas recirculation potentiometer - G212-

Removing and fitting  
⇒ [page 439](#)

4 - Seal

Renew following removal

5 - Seal

Renew following removal

6 - Bolt.

9 Nm

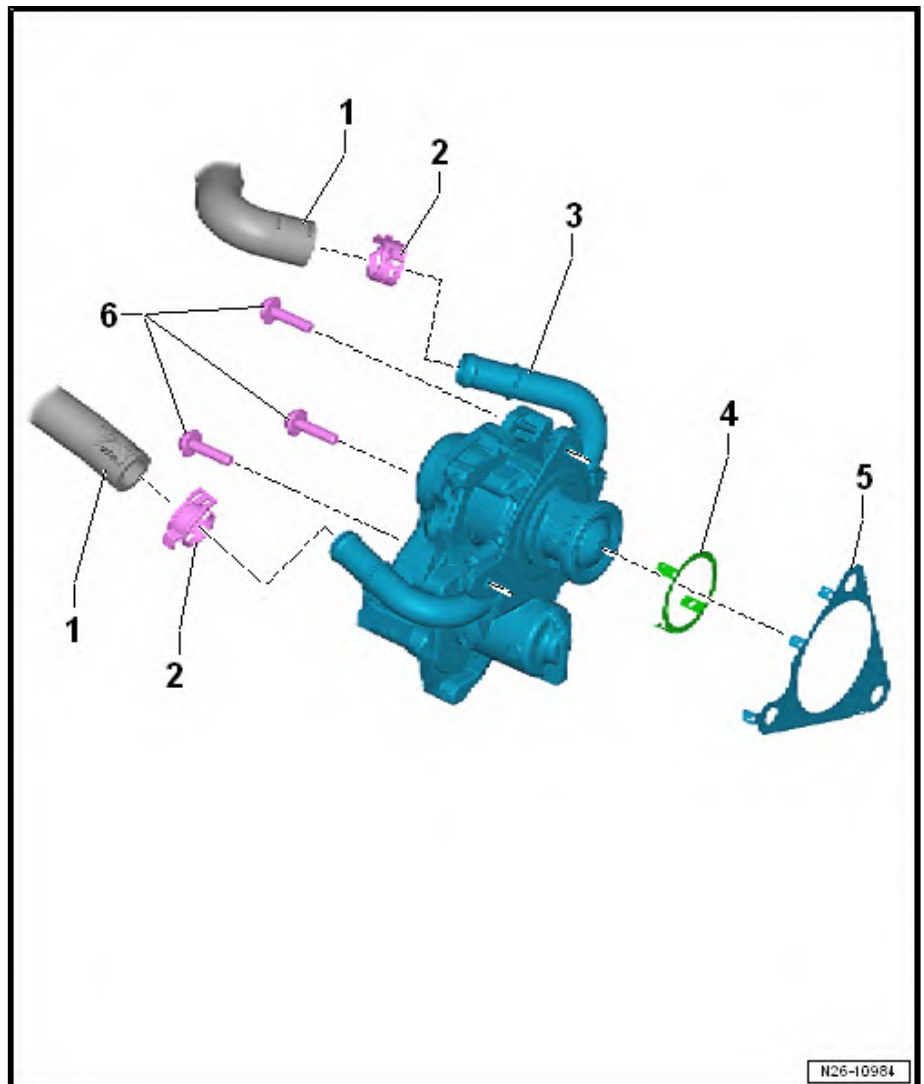

## 4.3 Removing and installing exhaust gas recirculation cooler

⇒ [“4.3.1 Removal and installation of the exhaust gas recirculation cooler, vehicles with front-wheel drive”, page 425](#)

⇒ [“4.3.2 Removal and installation of the exhaust gas recirculation cooler, vehicles with all-wheel drive”, page 431](#)

⇒ [“4.3.3 Removal and installation of the exhaust gas recirculation cooler, engine codes CRVA, CRVC, CRGA”, page 436](#)

### 4.3.1 Removal and installation of the exhaust gas recirculation cooler, vehicles with front-wheel drive

Special tools and workshop equipment required

- ◆ Hose clip pliers - VAS 6340-

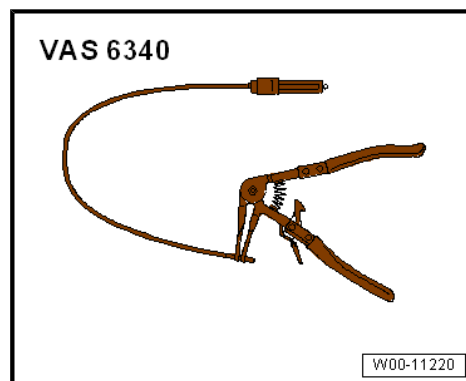

- ◆ Socket insert XZN 10 - T10501-



- ◆ Hooks - T40207-

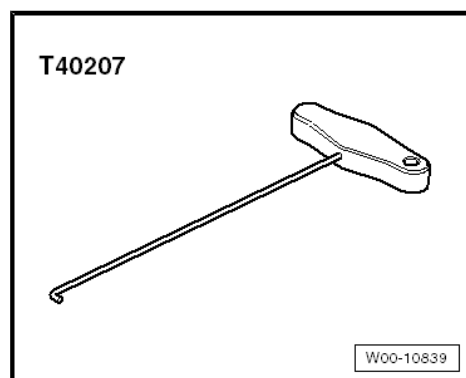

- ◆ Sealing cap set for engine - VAS 6122-

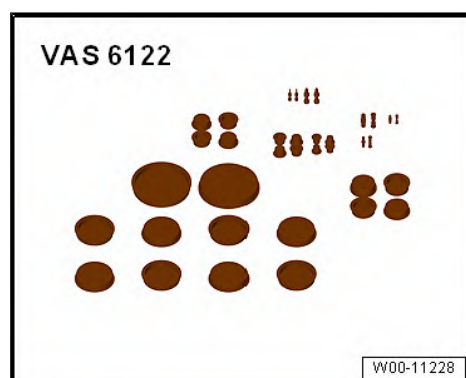

## Removal

- Drain coolant ⇒ [page 181](#) .

### Leon, Leon ST Variant 1

- Disconnect electrical connections, take cable out of the brackets and place over the engine.
- 2 - For exhaust gas temperature sender 4 - G648-
- 3 - For exhaust gas temperature sender 3 - G495-
- 4 - For Lambda probe 1 before catalytic converter - GX10- .

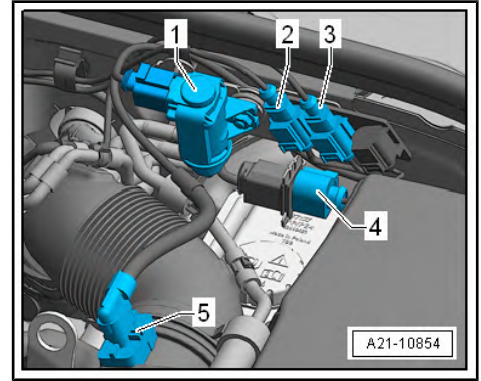

- Open heat insulation sleeve -1-.
- Take electrical connector -4- out of bracket, unplug it and move electrical wiring clear.

**i** Note

Ignore -item 5-.

- Unplug electrical connectors -3- and move wiring harness clear.
- Remove bolt -2- and move bracket with pressure differential sender - G505- towards rear.
- Remove bolt -arrows-.

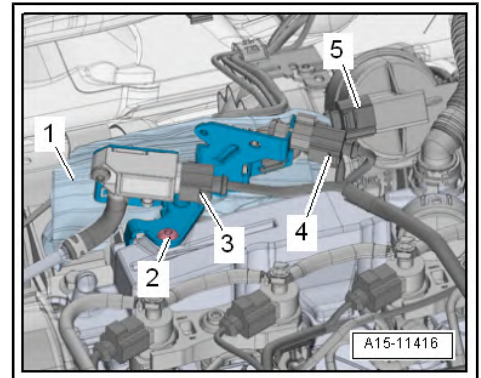

**i** Note

Disregard -item A-.

- Unhook pipe line -B- and remove with the pressure differential sender - G505- .

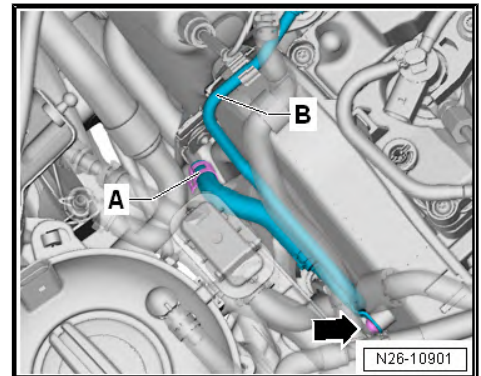

### Leon, Leon ST Variant 2

- Disconnect electrical connections, take cable out of the brackets and place over the engine.
- 1 - For exhaust gas temperature sender 4 - G648-
- 2 - For exhaust gas temperature sender 3 - G495-
- 3 - For exhaust gas temperature sender 2 - G448-
- 4 - For Lambda probe 1 before catalytic converter - GX10- .

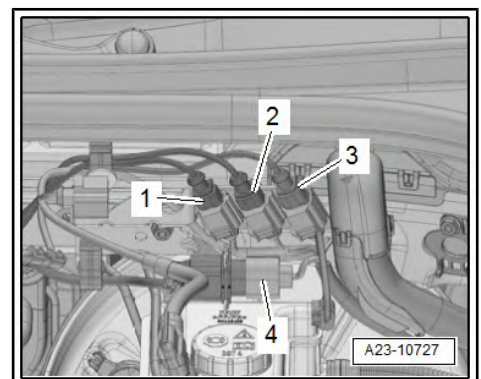

- Open heat insulation sleeve -1-.
- Take electrical connector -5- out of bracket, unplug it and move electrical wiring clear.

**i Note**

Ignore -item 6-.

- Disconnect plug-in connectors -3 and 4- and expose electrical wiring harness.
- Unscrew the bolt -2-.
- Unscrew the bolt -3-.

**i Note**

Ignore -item 1-.

- Unhook pipe line -2- and remove with the pressure differential senders.

**All vehicles (continued):**

- For reasons of space, remove the air filter housing together with the intake hose ⇒ [page 321](#) .
- Press the release buttons on the crankcase breather hose -1- and remove it from the cylinder head cover.
- Unscrew bolt -3-, swing air pipe with inlet connection -2- to rear and pull off from turbocharger.
- Loosen the clamp -1-, remove the screws -arrows-, and separate the air hose with the resonator-2-.
- Remove front exhaust pipe ⇒ [page 378](#) .

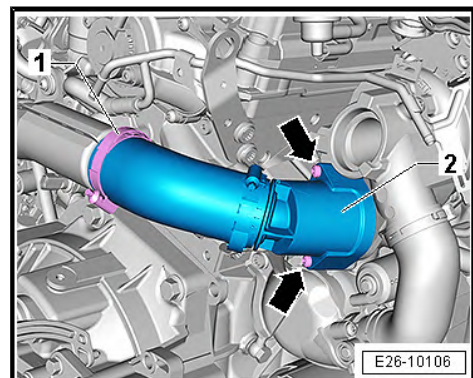
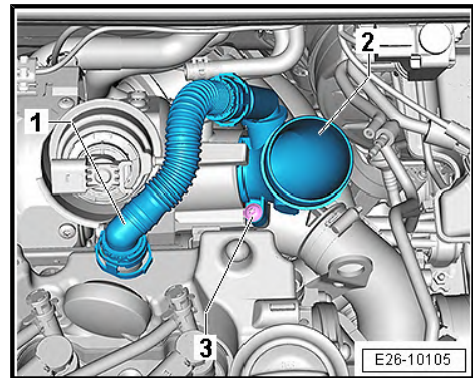
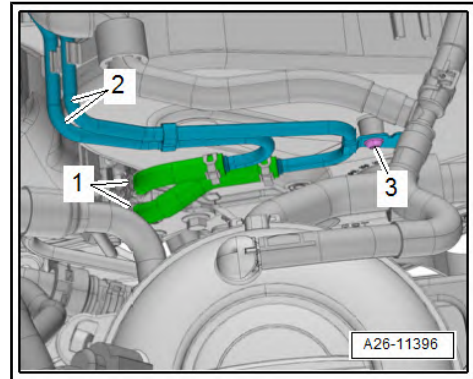
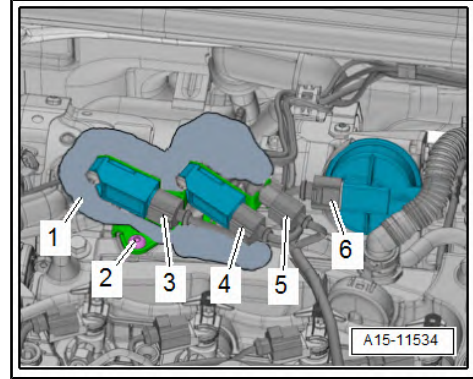

- Remove hose clamp -3- from the air hose from above.

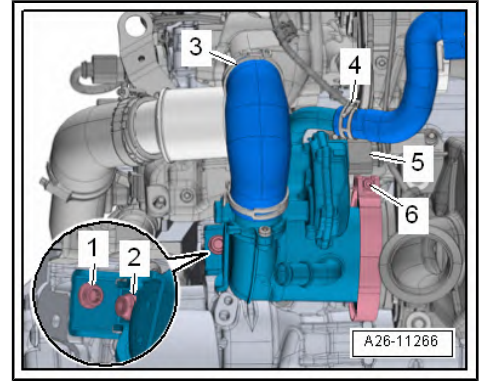

- Open clip -1- and place it on intake funnel of emission control module.

**i** Note

*Ignore the assembly aides - T10511- .*

- Unscrew the bolt -5-.
- Unscrew securing bolts -2- and -3-.
- Unscrew the mounting nuts -4-.

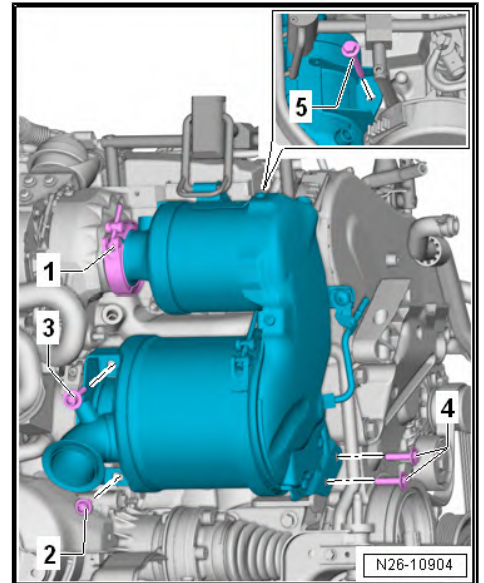

- Loosen the hose clips -1-, remove the coolant hoses.

**i** Note

*Item -4- can be disregarded.*

- Unscrew the nuts -3- and the bolts -2- and lay the rear coolant hose to the side.

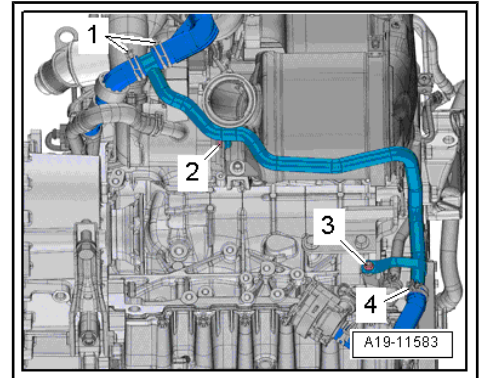

- Push heat insulation sleeve to one side and unplug electrical connector -5-.

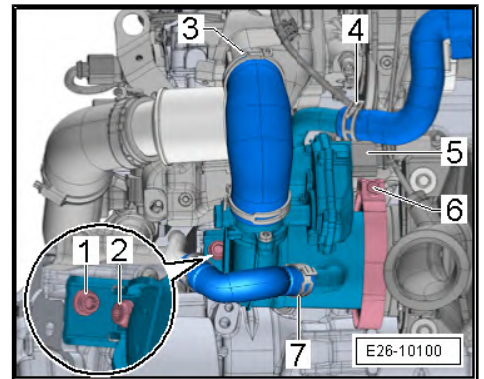



**Note**

Use the hook to disconnect the electrical -plug - connection 5 - T40207- . Release the plug lock -1- -in the direction of the arrow-.

- Release hose clips -4- and -7-, and separate the hoses of the radiator for exhaust gas return, use the engine cap set - VAS 6122- .
- Loosen bolt -6- and push screw-type clip towards particulate filter.
- Remove bolt -1- and remove bolt -2- with the socket wrench XZN 10 - T10501- .

- Pull out the exhaust gas recirculation cooler-1- through the tunnel opening.

**Installation**

Installation is carried out in the reverse order; note the following:



**Note**

- ◆ Check insulation mat for damage and renew it if necessary.
- ◆ If the insulation mat is damaged, check the exhaust gas recirculation control motor 2 - V339- for damage caused by heat and renew it if necessary.
- ◆ Renew seals, screw-type clip and hose clips after each removal.
- ◆ Secure all hose connections with the correct type of hose clips (same as original equipment) ⇒ *Electronic parts catalogue* .

- Fit hose -2- on exhaust gas recirculation cooler -1-.
- Fitting position: the marking “EGR side” -arrow- faces exhaust gas recirculation cooler.
- Ensure that air hose is not under tension.

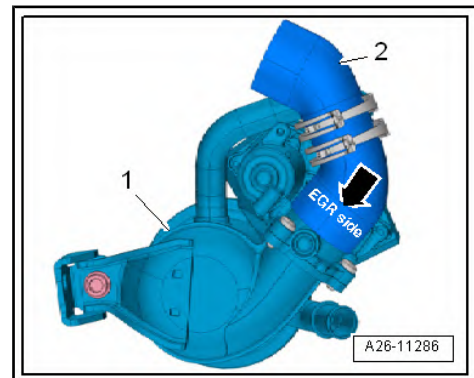
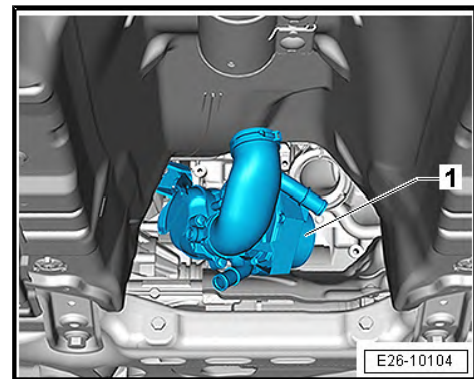
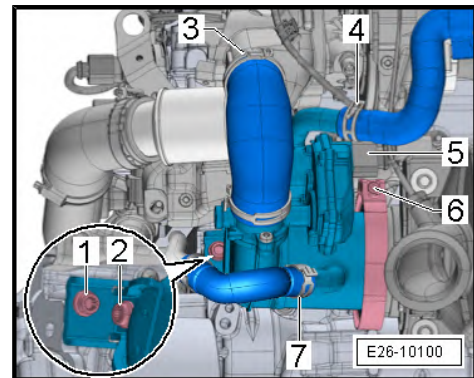
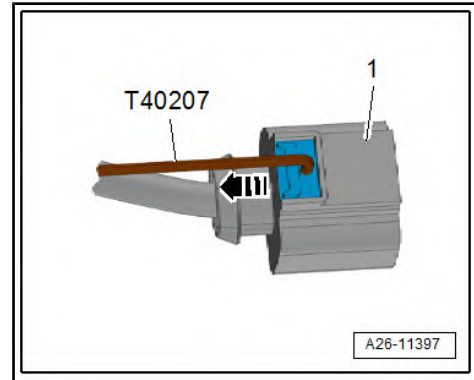

- Fit exhaust gas recirculation cooler -1- with seal and screw-type clip on emission control module.
- Turn exhaust gas recirculation cooler anti-clockwise -arrow- and at the same time attach hose -3- to turbocharger -2-.

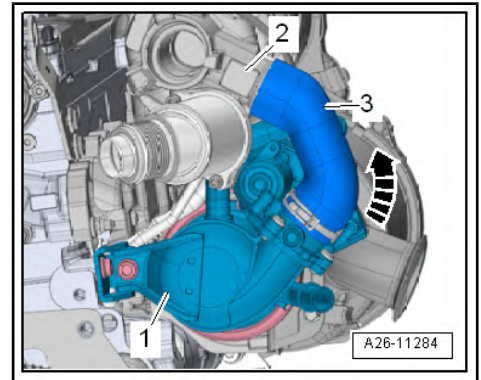

- Fit screw-type clip -6- in correct installation position  
⇒ [page 422](#) .
- Tighten connections ⇒ [page 422](#) .

#### Specified torques

- ◆ ⇒ [Fig. ““Tightening sequence for emission control module””](#), [page 398](#)
- ◆ ⇒ [“3.1 Exploded view - coolant pipes”](#), [page 208](#)
- ◆ ⇒ [“1.2 Removing and installing front exhaust pipe with catalytic converter”](#), [page 378](#)
- ◆ Exhaust gas recirculation cooler - tightening torque and sequence  
⇒ [Fig. ““Exhaust gas recirculation cooler - tightening torque and sequence””](#), [page 422](#)

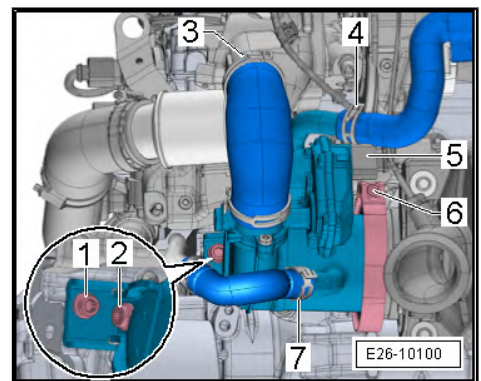

### 4.3.2 Removal and installation of the exhaust gas recirculation cooler, vehicles with all-wheel drive

#### Special tools and workshop equipment required

- ◆ Hose clip pliers - VAS 6340-

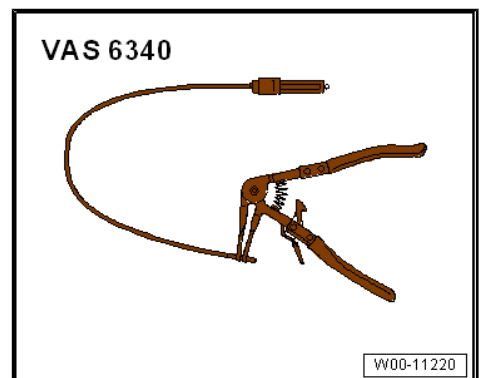

- ◆ Socket insert XZN 10 - T10501-



- ◆ Hooks - T40207-

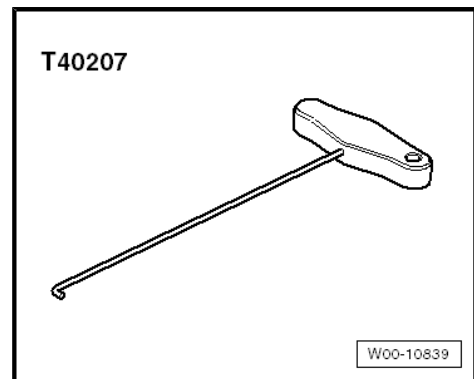

### Removal

- For reasons of space, remove the air filter housing together with the intake hose ⇒ [page 321](#) .
- Press the release buttons on the crankcase breather hose -1- and remove it from the cylinder head cover.
- Unscrew bolt -3-, swing air pipe with inlet connection -2- to rear and pull off from turbocharger.
- Remove battery tray ⇒ Electrical system; Rep. gr. 27 ; Battery; Removing and installing battery tray .

Remove left coolant hose as follows:

- Drain coolant ⇒ [page 181](#) .
- Remove bolts -arrows-.
- Release screw-type clip -2- and detach air pipe -1-.

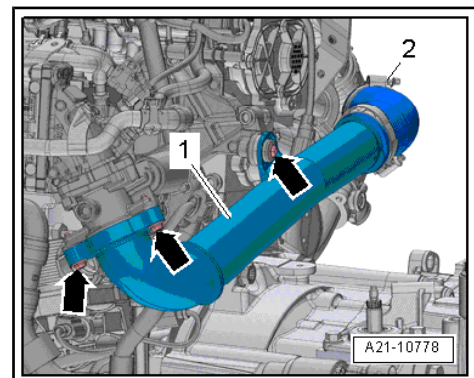
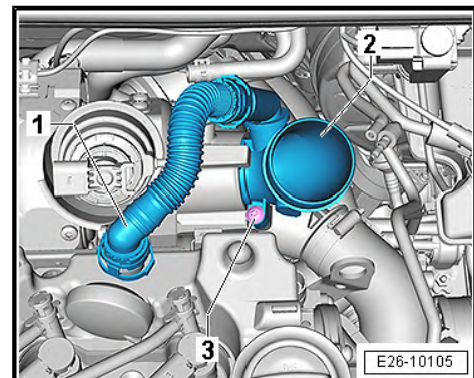

- Unscrew bolts -arrows- and remove resonator -1-.

#### Vehicles with manual gearbox

- Remove the gear and gate selector cables from the gearbox, unscrew and remove the cable support bracket and place it to one side with the cables => Rep. gr. 34 ; Selector mechanism .

#### Vehicles with duplex clutch drive DSG 0CW:

- Remove the gate selector cable from the gearbox, unscrew and remove the support bracket and tie it up with the cables => Rep. gr. 34 ; Selector mechanism .

#### Vehicles with dual clutch gearbox 0D9

- Remove the selector lever cable from the gearbox and pull it out from the cable support bracket => Rep. gr. 34 ; Selector mechanism .

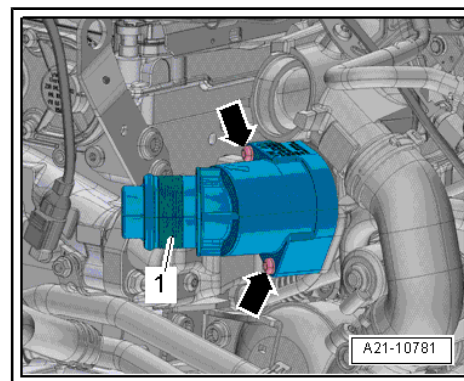

#### Vehicles with left-hand coolant pipes version 1

- Unscrew nut -4- and bolt -3-.
- Loosen the hose clips -arrows-, remove the coolant hoses.
- Remove left coolant hose and lay to the side.



#### Note

Disregard -item 1, 2-.

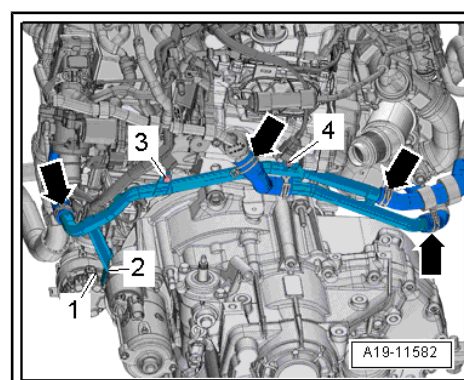

#### Vehicles with left-hand coolant pipes version 2

- Unscrew nut -4- and bolt -3-.
- Loosen the hose clips -arrows-, remove the coolant hoses.
- Remove left coolant hose and lay to the side.



#### Note

Disregard -item 1, 2-.

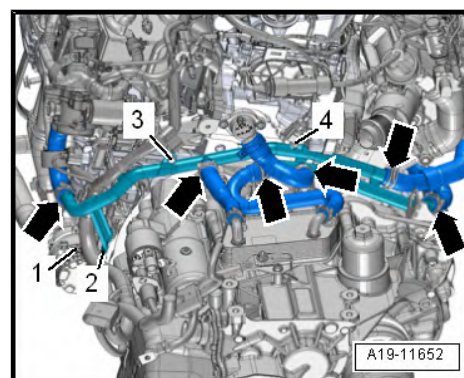

**All vehicles (continued):**

- Remove front exhaust pipe ➔ [page 378](#) .
- If installed, remove screws -arrows- and remove the heat shield -1- .

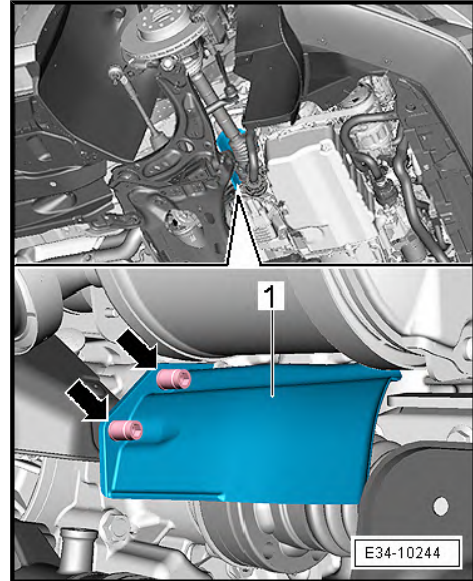

- Remove screws -A- and -B- from the bevel box and remove the heat shield -1- .

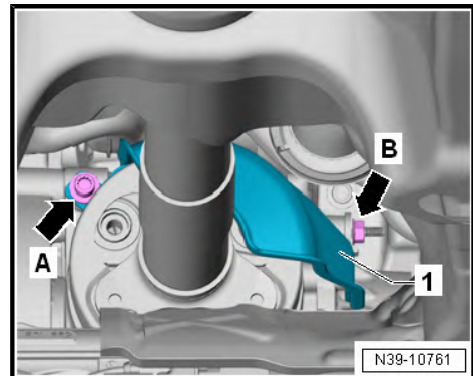

Remove rear coolant hose as follows:

**i Note**

*Item -4- can be disregarded.*

- Unscrew the nuts -3- and the bolts -2- and lay the rear coolant hose to the side.

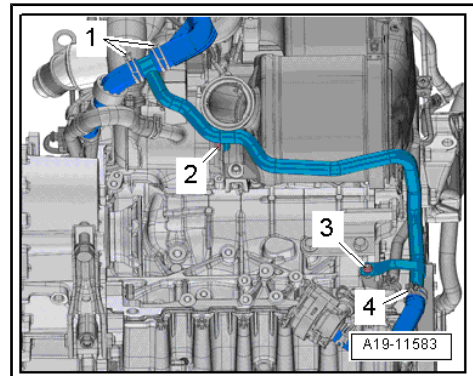

- Push heat insulation sleeve to one side and unplug electrical connector -5-.

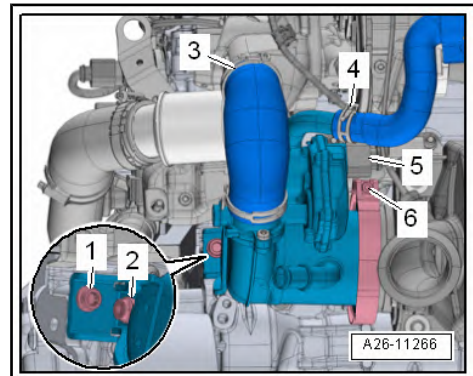

 **Note**

Use the hook to disconnect the -plug - connection 5 - T40207-. Release the plug lock -1- -in the direction of the arrow-.

- Loosen the hose clip -4-, remove the coolant hose.
- Loosen the hose clip -3-, remove the air intake hose.
- Loosen bolt -6- and push screw-type clip towards particulate filter.
- Remove bolt -1- and remove bolt -2- with the socket wrench XZN 10 - T10501- .
- Remove exhaust gas recirculation cooler -1- on gearbox side -arrow-.

**Installation**

Installation is carried out in the reverse order; note the following:

 **Note**

- ◆ Check insulation mat for damage and renew it if necessary.
- ◆ If the insulation mat is damaged, check the exhaust gas recirculation control motor 2 - V339- for damage caused by heat and renew it if necessary.
- ◆ Renew seals, screw-type clip and hose clips after each removal.
- ◆ Secure all hose connections with the correct type of hose clips (same as original equipment) ⇒ *Electronic parts catalogue* .
- Fit hose -2- on exhaust gas recirculation cooler -1-.
- Fitting position: the marking "EGR side" -arrow- faces exhaust gas recirculation cooler.
- Ensure that air hose is not under tension.

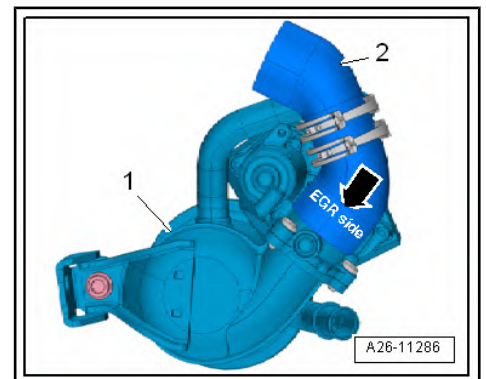
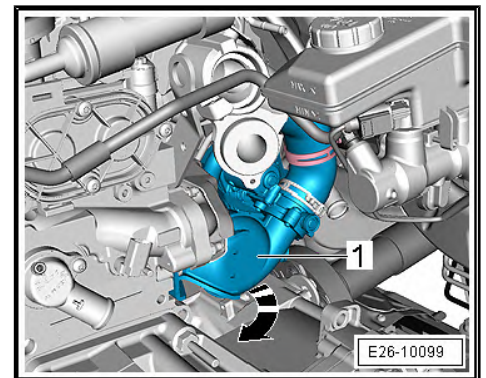
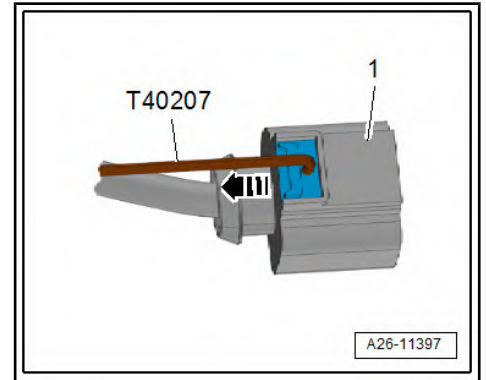

- Fit exhaust gas recirculation cooler -1- with seal and screw-type clip on emission control module.
- Turn exhaust gas recirculation cooler anti-clockwise -arrow- and at the same time attach hose -3- to turbocharger -2-.

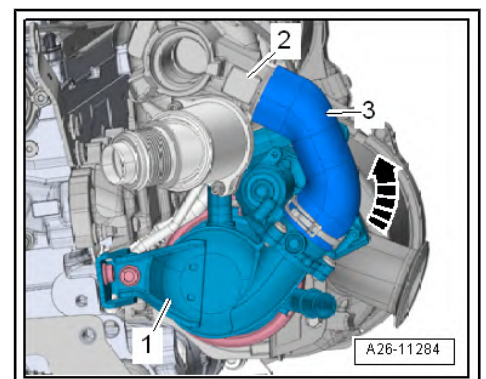

- Fit screw-type clip -3- in correct installation position ⇒ [page 422](#) .
- Tighten connections ⇒ [page 422](#) .

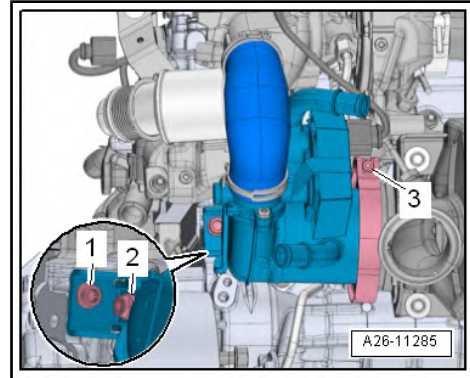

- Tighten bolt -2- and then nut -3-



#### Note

Secure all hose connections with the correct type of hose clips (same as original equipment) ⇒ *Electronic parts catalogue* .

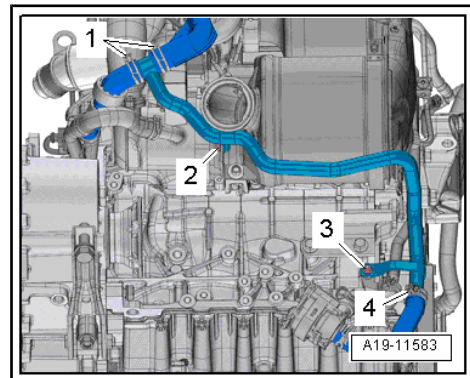

- Attach heat guard -1- to the bevel box.

#### Tightening torque:

- ◆ Bolt -A- 20 Nm
- ◆ Bolt -B- 40 Nm
- Install heat shield for the drive shaft, tightening torque 20 nm.
- Install coolant pipes (left-side) ⇒ [page 215](#) .

#### Specified torques

- ◆ ⇒ [Fig. "Exhaust gas recirculation cooler - tightening torque and sequence"](#) , [page 422](#)
- ◆ ⇒ ["3.1 Exploded view - coolant pipes"](#) , [page 208](#) .
- ◆ ⇒ Electrical system; Rep. gr. 27 ; Battery; Assembly overview - battery
- ◆ ⇒ ["1.1 Exploded view - silencers"](#) , [page 366](#)
- ◆ ⇒ Rep. gr. 34 ; Selector mechanism; Assembly overview: cable support bracket

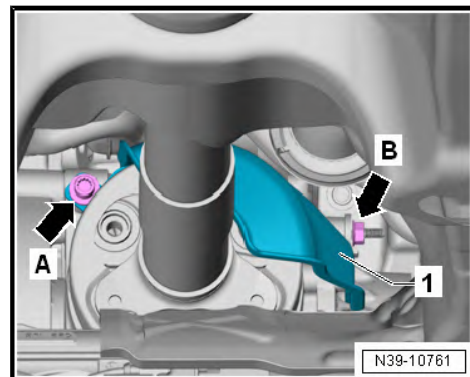

### 4.3.3 Removal and installation of the exhaust gas recirculation cooler, engine codes CRVA, CRVC, CRGA

#### Special tools and workshop equipment required

- ◆ Socket - T10347-



- ◆ Socket insert XZN 10 - T10501-



- ◆ Wrench kit - T10395 A-



### Removal

- Remove catalytic converter ⇒ [page 388](#) .
- Drain coolant ⇒ [page 181](#) .
- Open clamp -1- and detach hose. Remove nuts -arrows-.
- Tie coolant pipe upwards with cable ties.

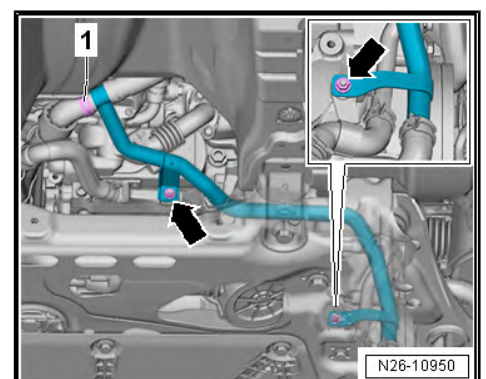

- Unscrew bolt -1- with socket - T10347- screw off nuts-2-.
- Remove connecting pipe -A-.

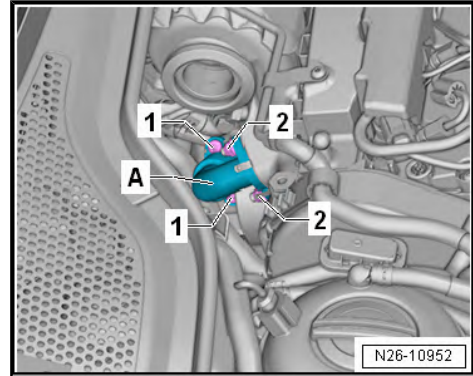

- Open the clamps -arrows- pull off the coolant hose screw out the temperature sensor for the exhaust gas recirculation - G98- -1- with a suitable tool from the tool set - T10395 A-

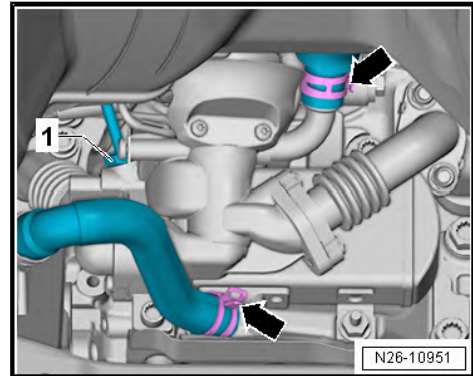

- Unscrew bolts -1- with socket XZN 10 - T10501- unscrew the holder for the vacuum line -2-.
- Pull off the vacuum line on the exhaust gas recirculation cooler.

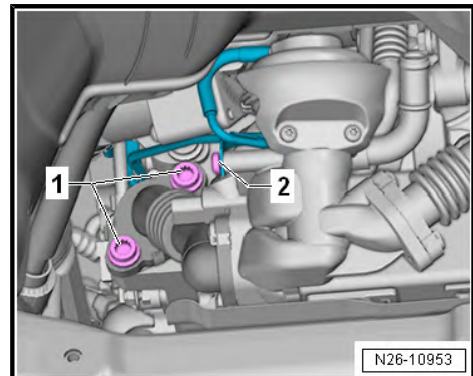

- Unscrew bolts -arrows- and carefully remove the exhaust gas recirculation cooler -A- through the vehicle tunnel.

### Installation

Installation is carried out in the reverse order; note the following:

#### Note

- ◆ Renew self-locking nuts and bolts as well as gaskets, seals and O-rings after each removal.
- ◆ Secure all hose connections with the correct type of hose clips (same as original equipment) ⇒ *Electronic parts catalogue* .
- ◆ When fitting, attach all cable ties back to the same location.

- Install catalytic converter ⇒ [page 388](#) .
- Replenish coolant ⇒ [page 184](#) .

### Specified torques

- ◆ Exploded view of exhaust gas recirculation ⇒ ["4.1.2 Assembly overview – exhaust gas recirculation, engine codes CRVA, CRVC, CRGA"](#), page 422

## 4.4 Removing and installing exhaust gas recirculation control motor - V338-

### Special tools and workshop equipment required

- ◆ Hose clamps, up to 25 mm - 3094-

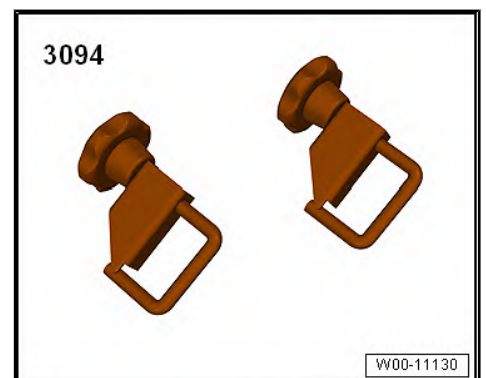
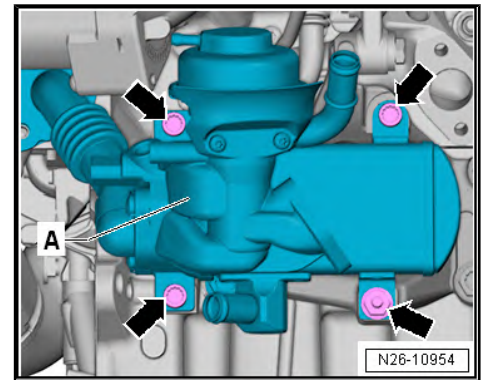

## Removal



### Note

Observe rules for cleanliness.

- Remove throttle valve control unit - J338- ➔ [page 328](#)
- Unplug the electrical connector -3-.
- Clamp off coolant hose with hose clamp -3094- .
- Loosen the hose clip -2-, remove the coolant hose.
- Unscrew bolts -arrows-, remove exhaust gas recirculation control motor - V338- .

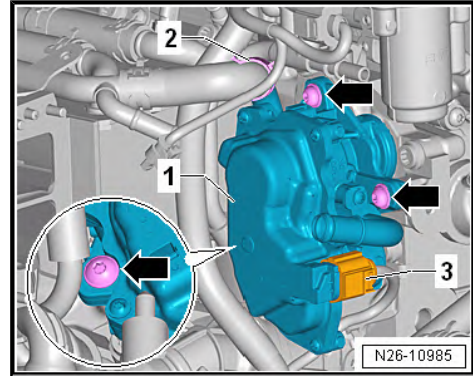

## Installation

Installation is carried out in the reverse order; note the following:



### Note

- ◆ *Renew seals*
- ◆ *Secure all hose connections with the correct type of hose clips (same as original equipment) ➔ [Electronic parts catalogue](#) .*
- Bleed cooling system ➔ [page 187](#) .

## Specified torques

- ◆ [Assembly overview - exhaust gas recirculation ➔ "4.2 Assembly overview - Control motor for exhaust gas recirculation V338", page 425](#)
- ◆ [Intake manifold - exploded view ➔ "5.1 Exploded view - intake manifold", page 323](#)

## 4.5 Removing and installing exhaust gas recirculation control motor 2 - V339-

### Special tools and workshop equipment required

- ◆ Hose clip pliers - VAS 6362-



## Removal

- Remove engine cover. ⇒ [page 56](#)
- Press the release button on the crankcase breather hose -1- and remove the hose from the cylinder head cover.
- Lay bare the vacuum hoses at the air pipe -arrows-.
- Loosen the hose clip -3-, remove the air intake pipe from the mass air flow sensor - G70- .
- Unscrew bolt -2-, swing air pipe with inlet connection to rear and pull off from turbocharger.
- If fitted, disconnect vacuum hose -arrow- and lay it to one side.

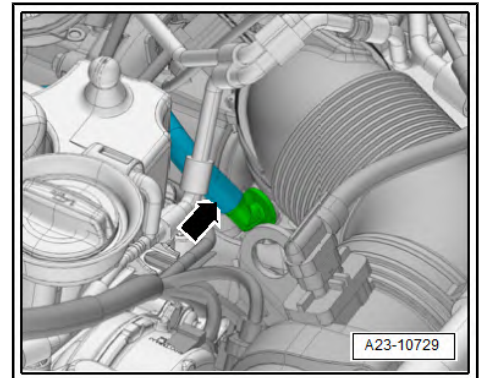
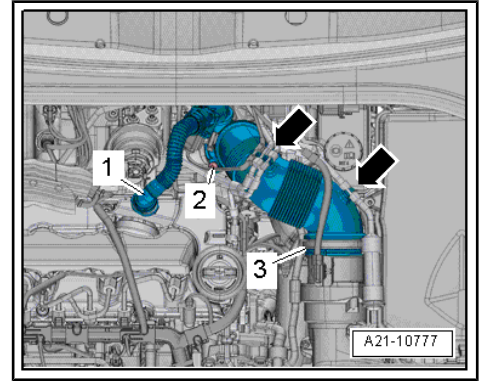

- Loosen the hose clips -1, 2-, remove the exhaust gas recirculation hose.
- Push heat insulation sleeve to one side and unplug electrical connector -3-.
- Unscrew bolts -arrows- and detach exhaust gas recirculation control motor 2 - V339- .

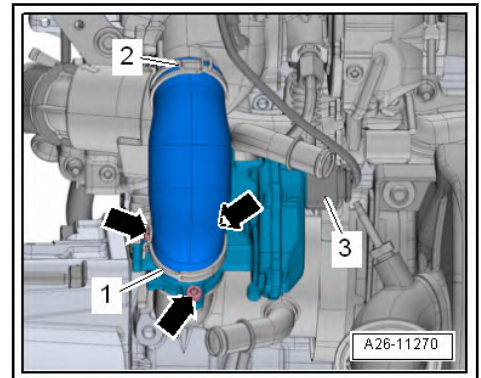

## Installation

Installation is carried out in the reverse order; note the following:

### Note

- ◆ *Renew seal and O-ring after removal.*
- ◆ *Secure all hose connections with the correct type of hose clips (same as original equipment) ⇒ [Electronic parts catalogue](#) .*
- Install engine cover panel ⇒ [page 56](#) .

## Specified torques

- ◆ ⇒ [“4.1.1 Assembly overview - exhaust gas recirculation”, page 420](#)
- ◆ ⇒ [“1.1 Exploded view - turbocharger”, page 252](#)

## 4.6 Check seal integrity of exhaust recirculation cooler

The exhaust gas recirculation cooler is checked for leaks using the ⇒ [Vehicle diagnostic tester](#). Connect the ⇒ [Vehicle diagnostic tester](#) to the vehicle and perform the function [Leak tightness of cooling system](#).



**Note**

*Depending on the vehicle, the engine and the firmware version of the vehicle diagnostic and service information system, the specified path may vary slightly.*

## 28 – Glow plug system

### 1 Glow plug system

⇒ [“1.1 Assembly overview - glow plug system”, page 443](#)

⇒ [“1.2 Removing and installing glow plug”, page 444](#)

⇒ [“1.3 Removing and installing automatic glow period control unit J179”, page 446](#)

⇒ [“1.4 Removing and installing Hall sensor G40”, page 447](#)

⇒ [“1.5 Removing and installing engine speed sensor G28”, page 447](#)

#### 1.1 Assembly overview - glow plug system

##### 1 - Hall sensor - G40-

- Removing and fitting  
 ⇒ [page 447](#)

##### 2 - Bolt.

- 9 Nm

##### 3 - O-ring

- No replacement part.  
 Renew Hall sender if damaged.

##### 4 - Glow plugs

- ◆ Glow plug 1 - Q10-
- ◆ Glow plug 2 - Q11-
- ◆ Glow plug 3 - Q12-
- ◆ Glow plug 4 - Q13-
- On some vehicles, a combustion chamber pressure sensor is integrated in the glow plug of cylinder 3; glow plug 3 - Q12- with cylinder 3 combustion chamber pressure sensor - G679-
- Glow plug without combustion chamber pressure sender: 17 Nm.
- Glow plug with combustion chamber pressure sender: 12 Nm.
- Removing and fitting  
 ⇒ [page 444](#)

##### 5 - Electrical connector

- For glow plug

##### 6 - Sealing flange (gearbox end)

- Removing and fitting ⇒ [page 67](#)

##### 7 - Sender wheel

- For engine speed sender - G28-
- Removing and fitting ⇒ [page 67](#)

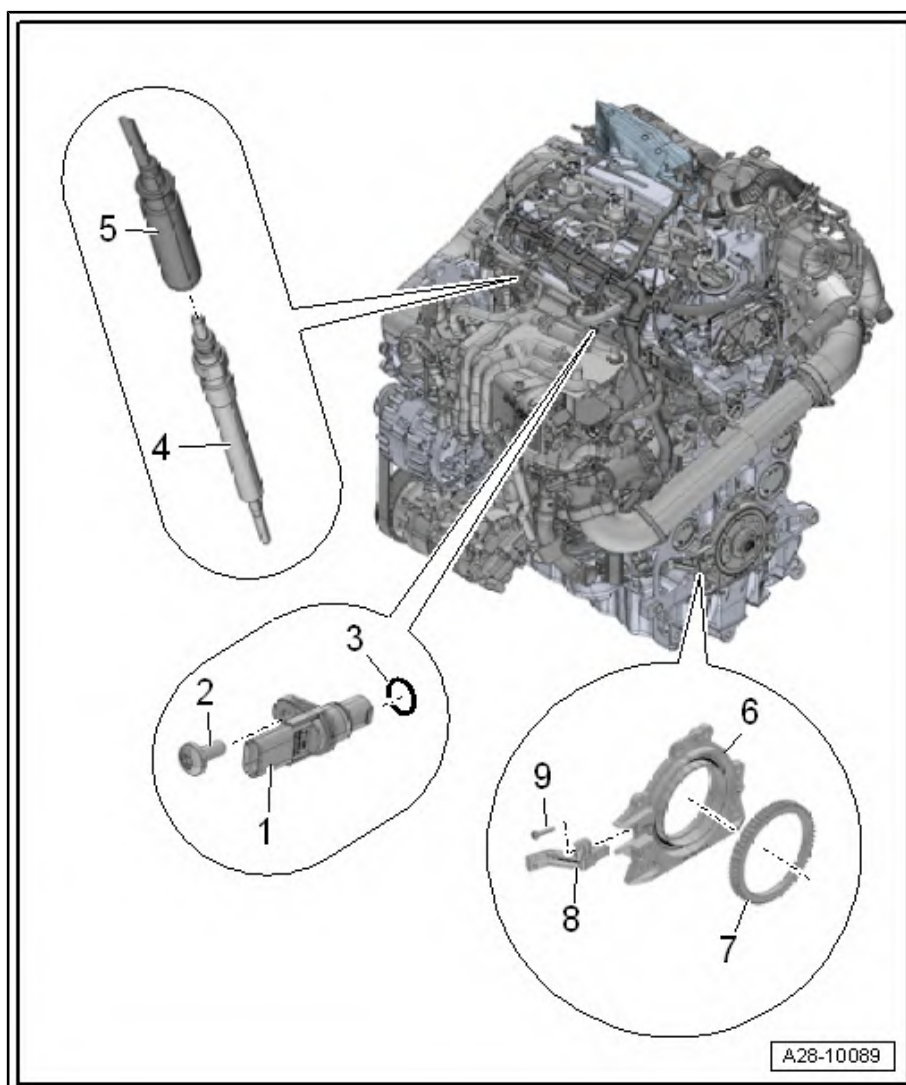

## 8 - Engine speed sensor - G28-

- ❑ Removing and fitting ⇒ [page 447](#)

## 9 - Bolt.

- ❑ 4.5 Nm

## 1.2 Removing and installing glow plug

### Special tools and workshop equipment required

- ◆ 10 mm articulated wrench - 3220-
- ◆ Socket insert AF 12 for glow plugs 4-cyl.TDI CR diesel - VAS 6454- for cylinder 3
- ◆ Pincers - 3314-

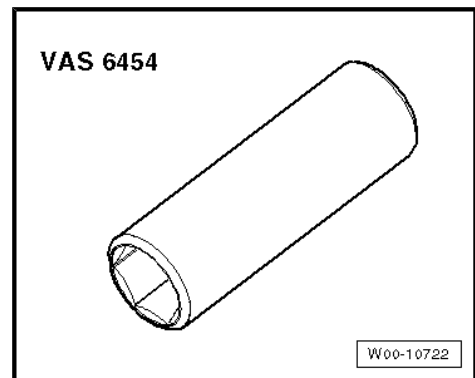
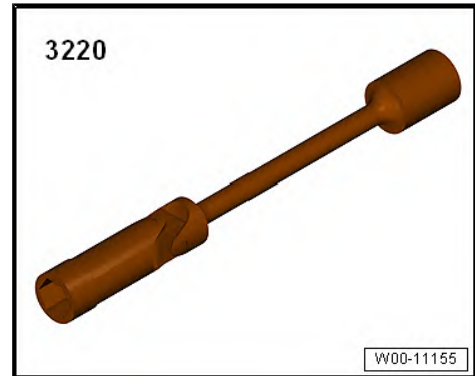

## Removal

### Glow plug version

- 1 - Glow plug with internal cylinder pressure sensor - not on all vehicles
  - 2 - Glow plug without combustion chamber pressure sender
- Remove engine cover. ⇒ [page 56](#)



### Caution

*Risk of damage to support sleeves.*

- ◆ *Use pliers - 3314- to remove glow plug connectors, squeezing just enough to grasp the collar of the support sleeve securely without damaging it.*

- Release retaining clips at wiring harness and pull connectors off glow plugs as follows:
- Apply groove -arrow A- of pliers - 3314- to collar of support sleeve -arrow B- as shown in illustration.
- Carefully detach glow plug connectors from glow plugs.
- Clean glow plug channel in cylinder head; make sure no dirt gets into cylinder.



### Note

- ◆ *Cleaning procedure:*
- ◆ *Use a vacuum cleaner to remove coarse dirt.*
- ◆ *Spray brake cleaner or suitable cleaning agent into glow plug opening, let it work in briefly and blow out with compressed air.*
- ◆ *Then clean glow plug opening using a cloth moistened with oil.*



### WARNING

*Risk of eye injury.*

- ◆ *Use safety goggles!*

- Loosen glow plugs using U/J extension and socket, 10 mm - 3220- and unscrew by hand.

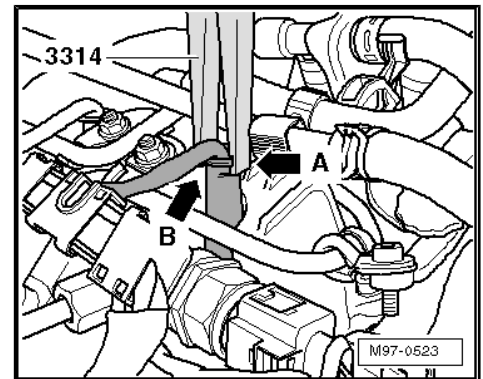
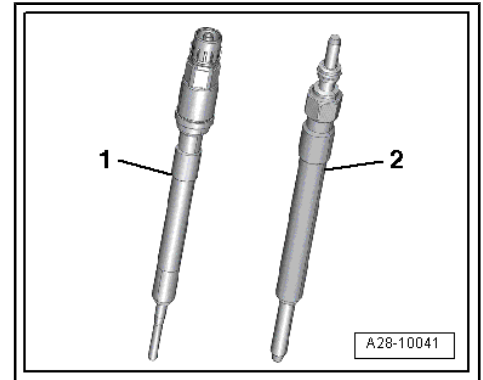



**Note**

On some vehicles, use socket insert AF 12 for glow plugs 4-cyl. TDI CR diesel - VAS 6454- for loosening the glow plug on cylinder 3.

**Installation**

Installation is carried out in the reverse order; note the following:

- Tightening torque  
⇒ ["1.1 Assembly overview - glow plug system", page 443](#)
- Fit glow plug connectors -1- back onto glow plugs -arrow-.



**Note**

Check that glow plug connectors are securely seated.

- Install engine cover panel ⇒ [page 56](#) .

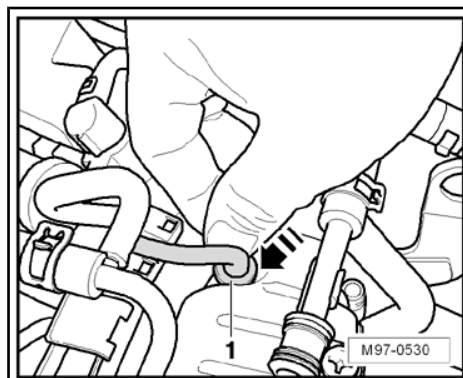
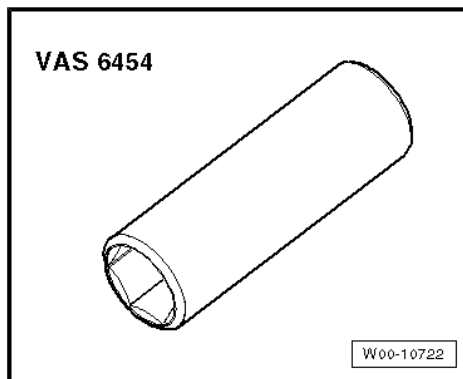

### 1.3 Removing and installing automatic glow period control unit - J179-

**Removal**

- Release fasteners -arrows- and detach cover.

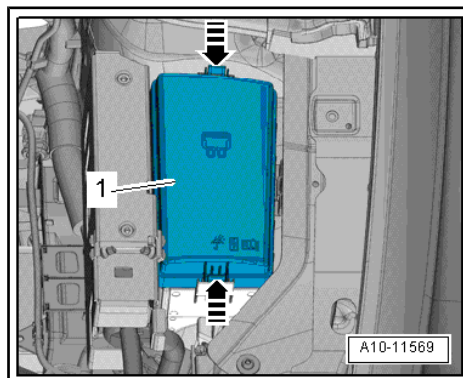

- Pull automatic glow period control unit - J179- -arrow- off slot in electronics box in engine compartment.

**Installation**

Installation is in the reverse sequence of removal.

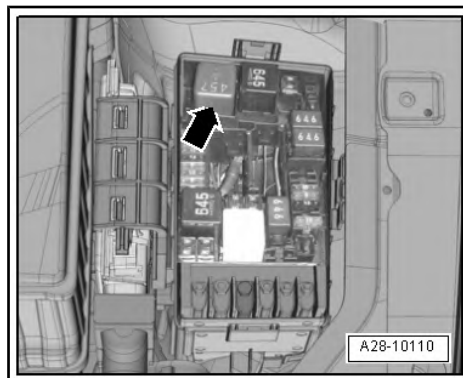

## 1.4 Removing and installing Hall sensor - G40-

### Removal

- Remove engine cover. ⇒ [page 56](#)
- Remove bolts -arrows- and push fuel lines slightly towards front.
- Unplug the electrical connector -2-.
- Unscrew bolt -1- and detach Hall sender - G40- .

### Installation

Installation is carried out in the reverse order; note the following:

- Tightening torque  
⇒ ["1.1 Assembly overview - glow plug system", page 443](#)
- Install engine cover panel ⇒ [page 56](#) .

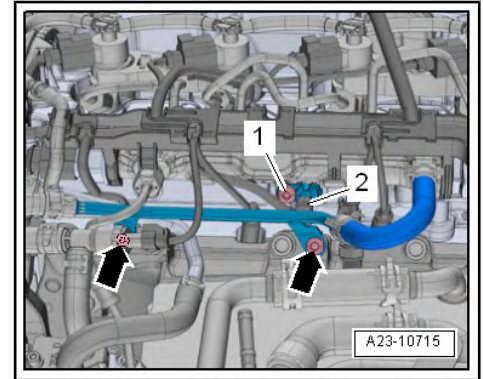

## 1.5 Removing and installing engine speed sensor - G28-

### Special tools and workshop equipment required

- ◆ Measuring tool - T10118-

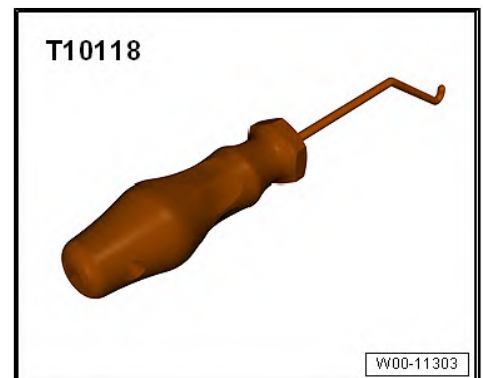

- ◆ Socket bit 4 mm - T10370-

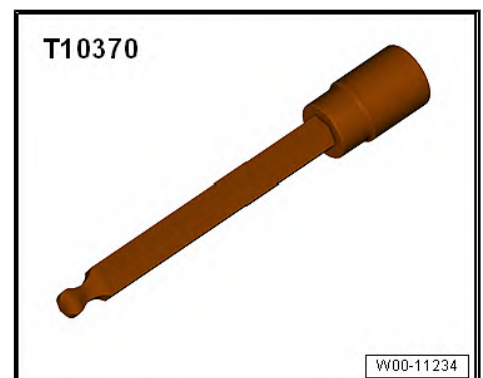

## Removal

- Remove noise insulation ⇒ General body repairs, exterior; Rep. gr. 66 ; Noise insulation; Removing and installing noise insulation .
- Use assembly tool - T10118- to unplug electrical connector -1-.



## Note

- ◆ *Use a screwdriver to release the connector, if the assembly tool - T10118- is not available.*
  - ◆ *Push on connector for engine speed sensor.*
  - ◆ *At the same time lift release tab with a thin wire hook.*
- Unscrew bolt -2- and detach engine speed sender - G28- .

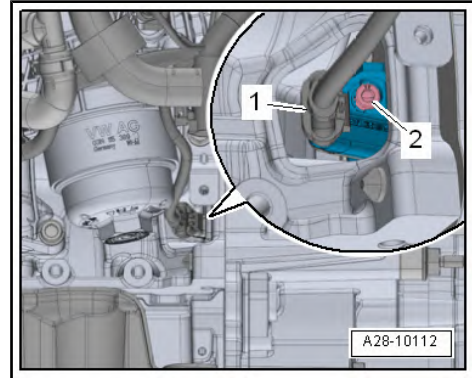

## Installation

Installation is carried out in the reverse order; note the following:

- Tightening torque  
⇒ ["1.1 Assembly overview - glow plug system", page 443](#)
- Install noise insulation ⇒ General body repairs, exterior; Rep. gr. 66 ; Noise insulation; Assembly overview - Noise insulation .